







## SPARE PARTS MANUAL: ENGINE

ART.NO.: 3CM080208MEN

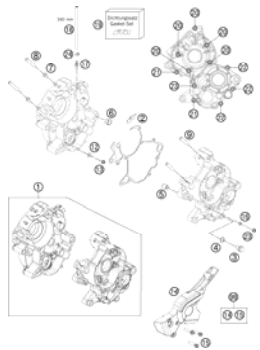
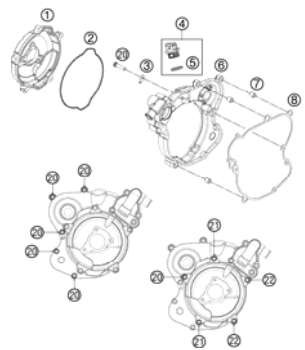
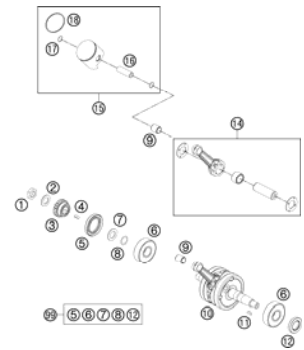
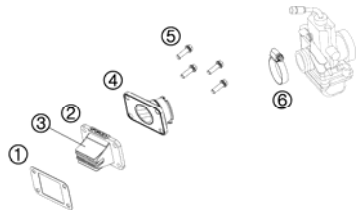
ENGLISH

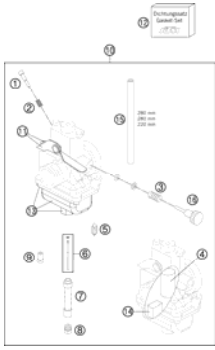
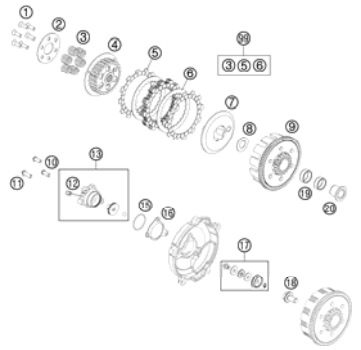
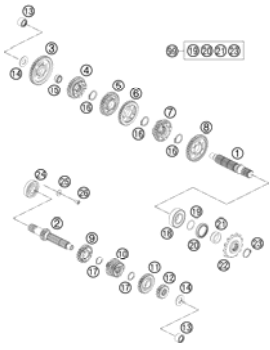

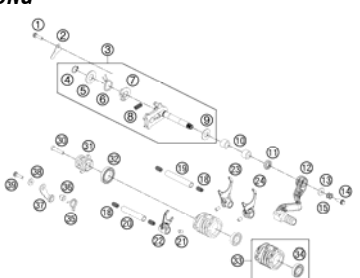

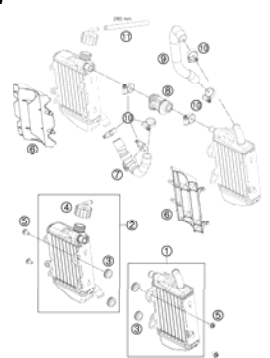
<b>ENGINE CASE</b>  <b>3</b>	<b>CLUTCH COVER</b>  <b>4</b>	<b>CRANKSHAFT, PISTON</b>  <b>5</b>	<b>REED VALVE CASE</b>  <b>6</b>
<b>ZYLINDER, ZYLINDERKOPF</b>  <b>7</b>	<b>VERGASER</b>  <b>9</b>	<b>KUPPLUNG</b>  <b>10</b>	<b>TRANSMISSION</b>  <b>11</b>
<b>KICKSTARTER</b>  <b>12</b>	<b>SCHALTUNG</b>  <b>13</b>	<b>WATER PUMP</b>  <b>14</b>	<b>KÜHLSYSTEM</b>  <b>15</b>

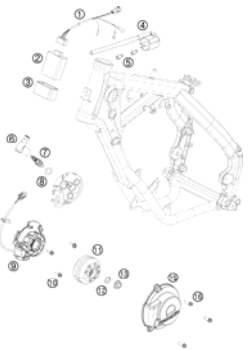
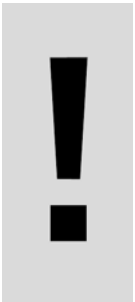
<p><b>IGNITION SYSTEM</b></p>  <p><b>16</b></p>			
	 <p>All information contained is without obligation. KTM-Sportmotorcycle AG particularly reserves the right to modify any equipment, technical specifications, prices, colors, shapes, materials, services, service work, constructions, equipment and the like so as to adapt them to local conditions or to cancel any of the above items, all without previous announcement and without giving reasons. KTM may stop manufacturing certain models without previous notice. KTM shall not be held liable for any deviations of availability and/or ability to deliver, illustrations, descriptions, printing and/or other errors. The illustrated models partly contain extra equipment, which is not applied to standard models. © by KTM-SPORTMOTORCYCLE AG, Mattighofen AUSTRIA; All rights reserved; Reprint, also in extracts, with written allowance of KTM-SPORTMOTORCYCLE AG, Mattighofen only.</p>		

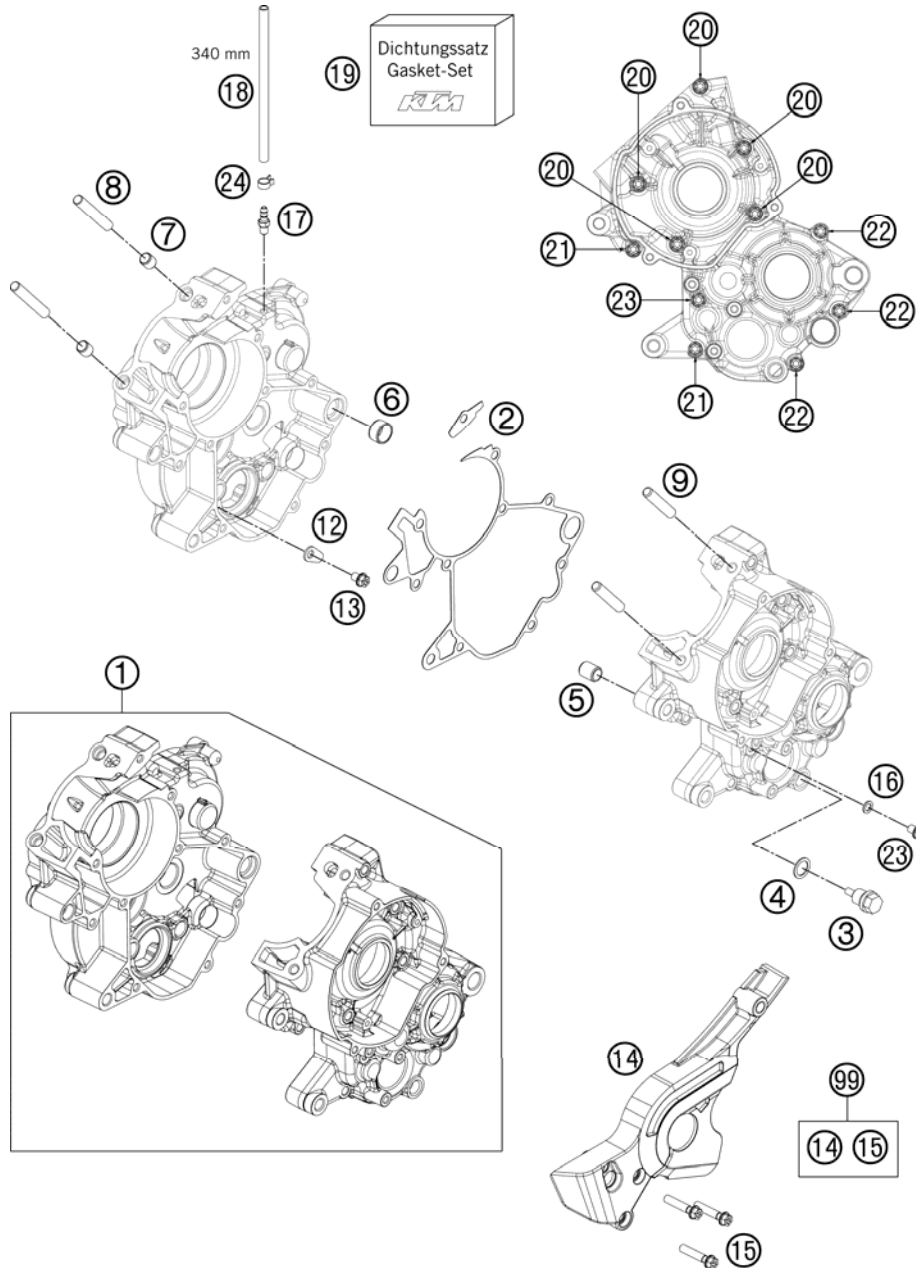

FIG	PART NUMBER	DESCRIPTION	QTY
1	4623000244	ENGINE CASE CPL. + BEARING	1
2	46230039000	ENGINE CASE GASKET	1
3	58030021000	OILDRAIN PLUG W.MAG. M 12X1,5	1
4	58038022000	CU-SEAL RING DIN7603-12X18X1,5	1
5	46230024000	DOWEL 12X9X14,5	1
6	46230123000	DOWEL 17/12.1/9.5	1
7	46030023000	DOWEL 10X8,2X10	2
8	0835080355	STUD DIN0835-M 8X35 10.9	2
9	46030043000	STUD M8X41	2
12	54634049000	RETAINING PLATE	1
13	0025060106	HH COLLAR SCREW M6X10 TX30	1
14	46230060000	CHAIN SPROCKET GUARD	1
15	0025060306	HH COLLAR SCREW M6X30 TX30	3
16	0603061001	CU-SEAL RING DIN7603-6X10X1	1
17	58336020190	VACUUM CONECTION M6/3MM '97	1
18	31007007101	PVC-HOSE 4X6MM	1
19	46230099000	GASKET SET 65 SX 2009	1
20	0025060556	HH COLLAR SCREW M6X55 TX30	5
21	0025060406	HH COLLAR SCREW M6X40 TX30	2
22	0025060306	HH COLLAR SCREW M6X30 TX30	3
23	0025060086	HH COLLAR SCREW M6X8 TX30	1
24	45230089000	YDNAC-CLAMP 10068 (6,8MM)	1
99	46204060010	SPROCKET COVER KIT	1

124623010 / C124623010

\* NEW PART

X AS REQUIRED

# CLUTCH COVER

65 SX 2013

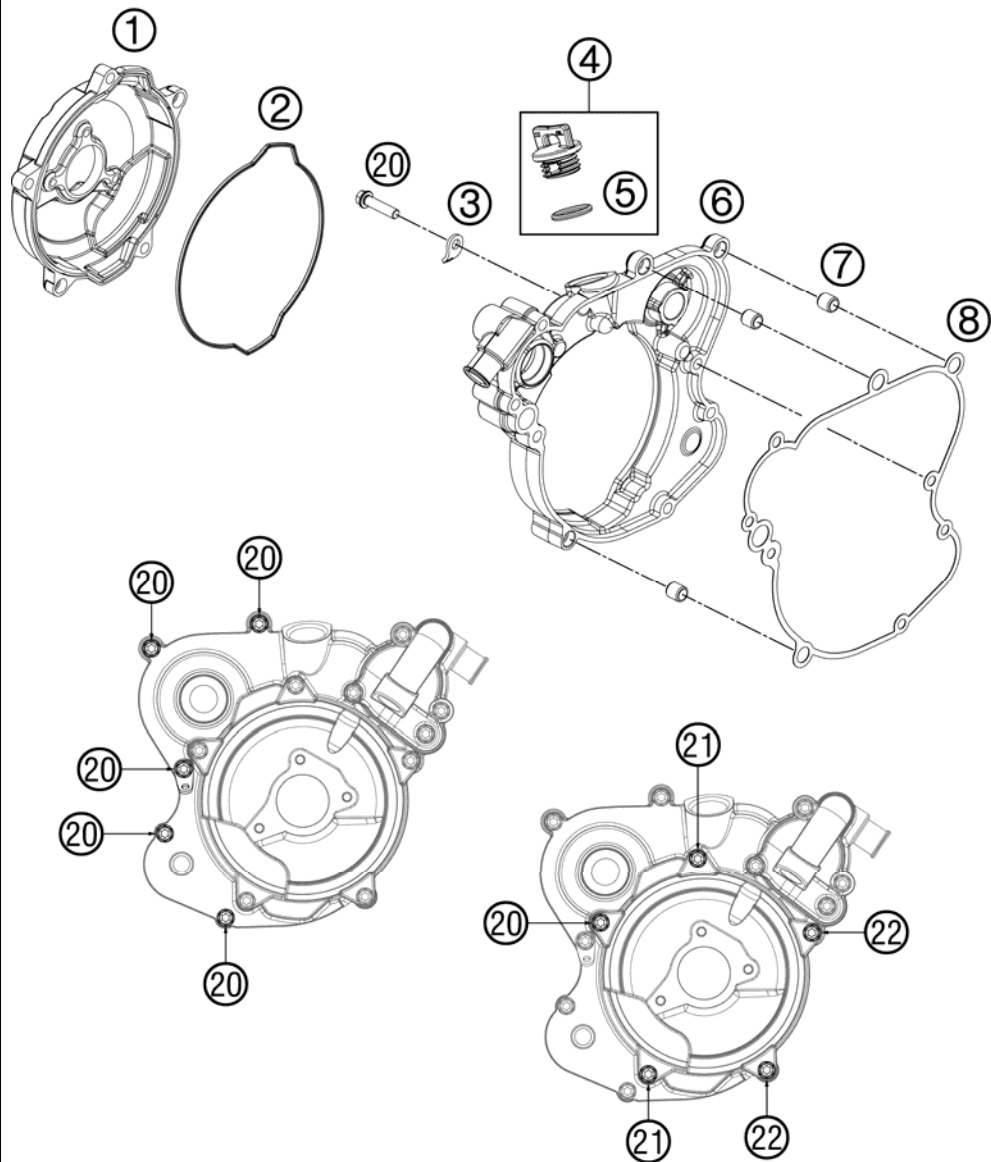

FIG	PART NUMBER	DESCRIPTION	QTY
1	46230026000	CLUTCH COVER OUTSIDE	1
2	46230027000	GASKET - CLUTCH OUTER COVER	1
3	51005074000	RETAINING PLATE	1
4	58030020100	PLUG CPL. M24X3	1
5	0770191015	O-RING 19,00X3,00 NBR	1
6	46230001100	INNER CLUTCH COVER	1
7	49030090000	DOWEL 9,8 X 7 X 10	3
8	46230025100	GASKET - CLUTCH INNER COVER	1
20	0025060256	HH COLLAR SCREW M6X25 TX30	6
21	0025060206	HH COLLAR SCREW M6X20 TX30	2
22	0025060556	HH COLLAR SCREW M6X55 TX30	2

124623020 / C124623020

\* NEW PART

X AS REQUIRED

# CRANKSHAFT, PISTON

65 SX 2013

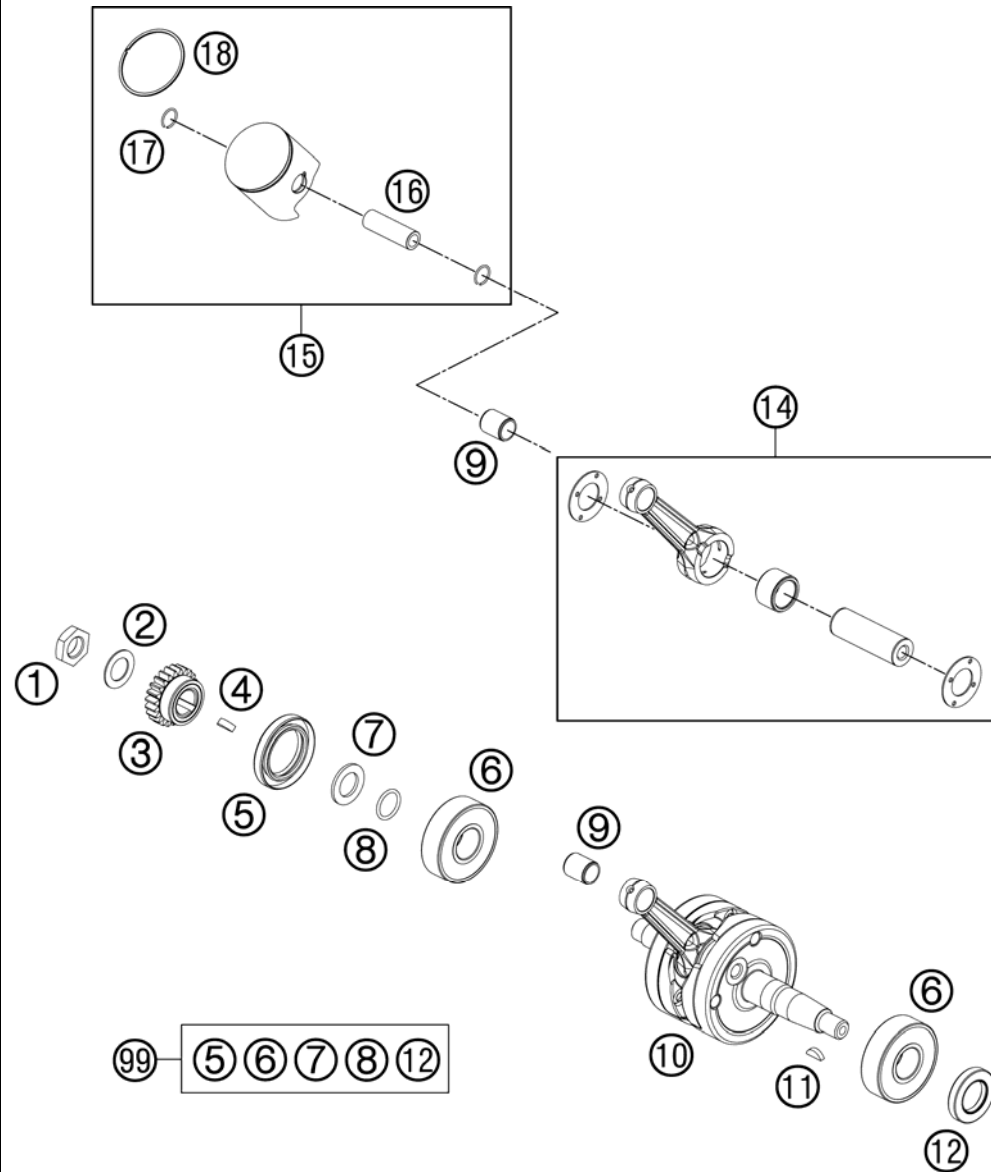

FIG	PART NUMBER	DESCRIPTION	QTY
1	46030029000	HH NUT 14X1,25X7 WS=22	1
2	83061015000	STOP DISK 15,2X25,7X1	1
3	46232023023	PRIMARY PINION LOOSE	1
4	0888040050	WOODRUFF KEY DIN6888 4X5X13	1
5	0760304772	SH.SEAL RING 30X47X7 BSL VITON	1
6	46030082200	GROOVED BALL BEAR.20X52X15 NTN	2
7	46230016000	SPACER WASHER - CRANKSHAFT	1
8	0770160021	O-RING 16,00X2,00 VITON	1
9	46030034000	NEEDLE BEAR.PISTONPIN 12X15X17	1
10	46230018000	CRANKSHAFT CPL.	1
11	0888030050	WOODRUFF KEY DIN6888-3X5X13	1
12	47030076100	SEAL SHAFT RING 20X35X6 BTSL	1
14	46230015000	CONNECT. ROD REPAIR SET	1
15	46230007000 I	PISTON CPL. I	x
15	46230007000 II	PISTON CPL. II	x
16	46030033000	PISTON PIN 12X38	1
17	45230074000	CIRCLIP 09	2
18	46030030500	PISTON RING 45MM 65CCM	1
99	00050002306	CRANKSHAFT REP. KIT 09-12	x

124623060 / C124623060

\* NEW PART

X AS REQUIRED

# REED VALVE CASE

65 SX 2013

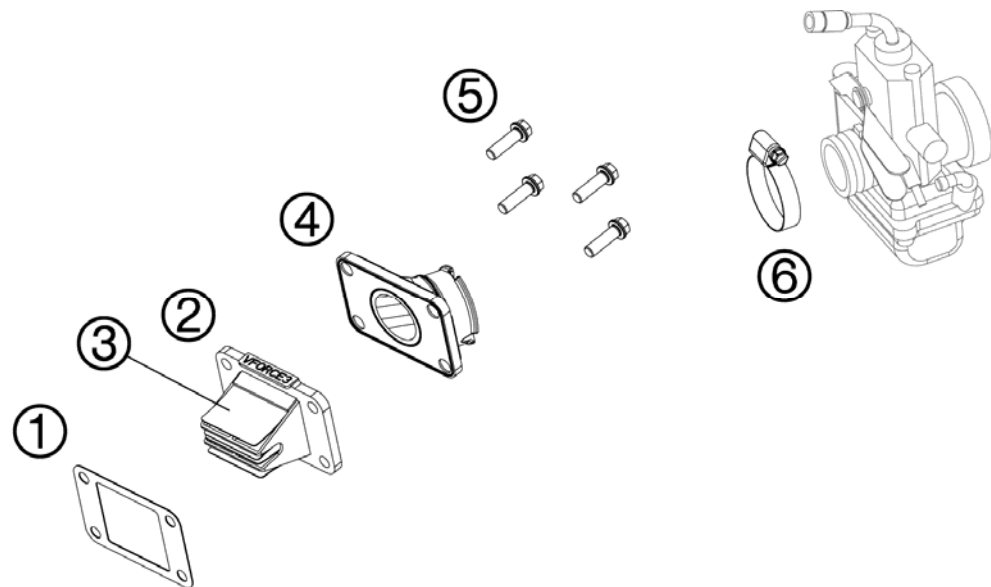

FIG	PART NUMBER	DESCRIPTION	QTY
1	46230049000	GASKET MEMBRAN CASE	1
2	46230051044	MEMBRANE CASE CPL. V-VORCE	1
3	46230052000	MEMBRANE	1
4	46230050000	INTAKE FLANGE	1
5	0025060206	HH COLLAR SCREW M6X20 TX30	4
6	10001120000	CLAMP 25-40 SGT 4	1

124623070 / C124623070

\* NEW PART

X AS REQUIRED



# ZYLINDER, ZYLINDERKOPF

65 SX 2013

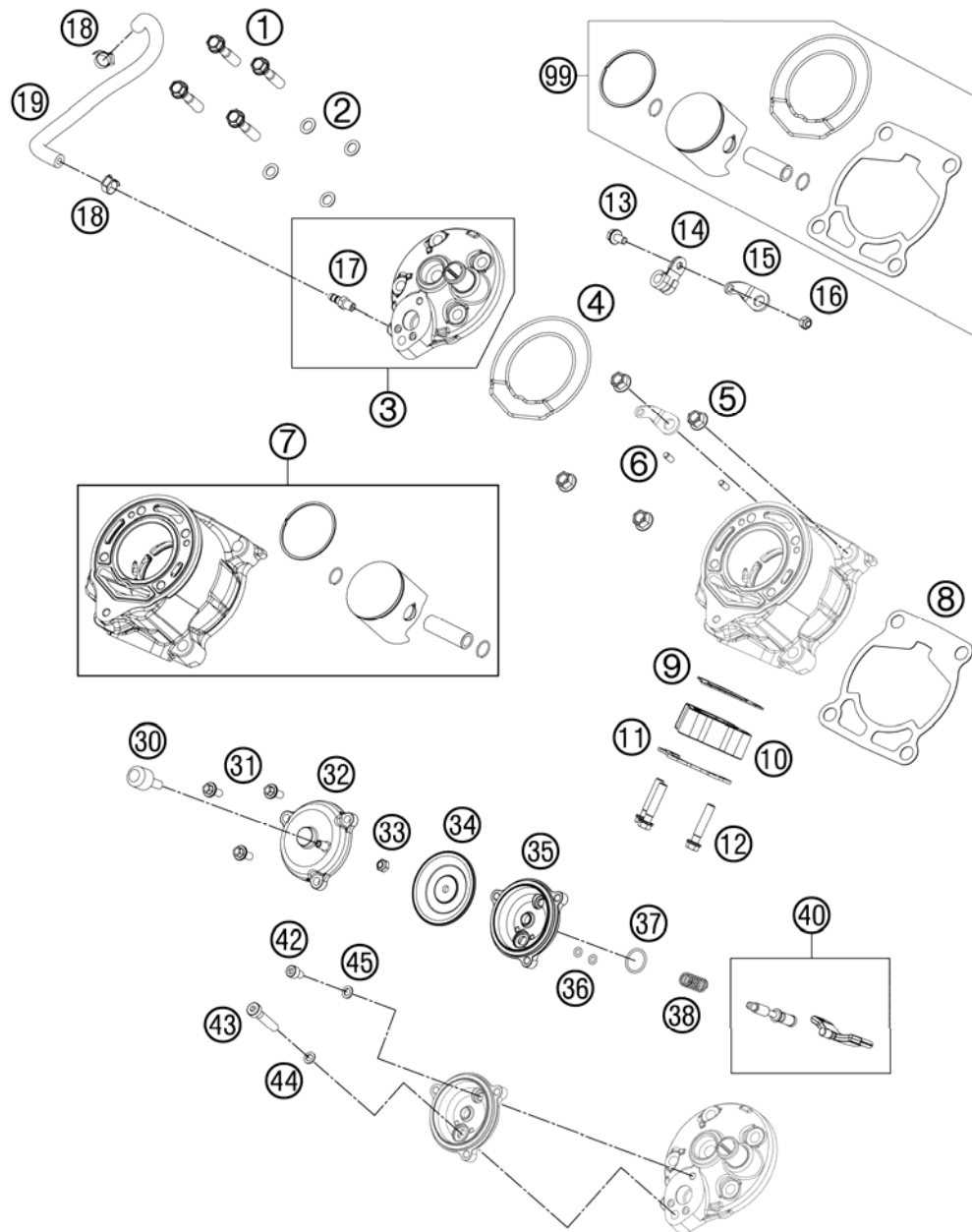

FIG	PART NUMBER	DESCRIPTION	QTY
1	50330079000	CYL. HEAD BOLT M 7X30 WS=10	4
2	0603070121	CU-SEAL RING DIN7603- 7,3X12X1	4
3	46230006000	CYLINDER HEAD	1
4	45230036000	CYLINDER HEAD GASKET	1
5	46030045000	COLLAR NUT M8 WS=10	4
6	0402040980	NEEDLE ROL.DIN5402 NRB 4X9,8	2
7	46230038000	CYLINDER + PISTON	1
8	46230035020	CYLINDER BASE GASKET 0,2 MM	x
8	46230035040	CYLINDER BASE GASKET 0,4 MM	x
8	46230035050	CYLINDER BASE GASKET 0,5 MM	x
8	46230035060	CYLINDER BASE GASKET 0,6MM	x
9	46205004000	EXHAUST PIPE FLANGE GASKET	1
10	46205003000	EXHAUST FLANGE	1
11	46205003050	BRACKET FOR SPRINGHOLDER	1
12	0025060306	HH COLLAR SCREW M6X30 TX30	3
13	0025050106	COLLAR SCREW M5X12 ISA30	1
14	45001070000	BRAKE CABLE CLAMP RSGU 9/12	1
15	46232060050	RETAINING PLATE CLUTCHHOSE	1
16	0985050003	SELF LOCKING NUT DIN0985-M 5	1
17	58336020190	VACUUM CONECTION M6/3MM '97	1
18	45031005000	YDNAC-CLAMP FUEL HOSE (8MM)	2
19	45237014000	HOSE	1
30	46237036044	VENTILATION CPL.	1
31	0014050163	HH COLLAR SCREW M 5X16 WS=6	3
32	46237035000	CLOSING COVER	1
33	0985050003	SELF LOCKING NUT DIN0985-M 5	1
34	46237013000	MEMBRANE	1
35	46237011000	FLANGE EXHAUST CONTROL	1
36	0770030015	O-RING 31X1,5 NBR 70	2
37	0770150151	O-RING 15,00X1,50 VITON	1
38	46237074100	ADJ. SPRING - EXHAUST CONTROL	1
40	46237020144	CONTROL SLIDE CPL.	1
42	0912050083	AH SCREW DIN 912 M 5X8	1
43	0012060303	% AH SCREW DIN6912 M6X30 8.8	1
44	0603061001	CU-SEAL RING DIN7603-6X10X1	1

124623050 / C134623050

\* NEW PART

X AS REQUIRED

# ZYLINDER, ZYLINDERKOPF

65 SX 2013

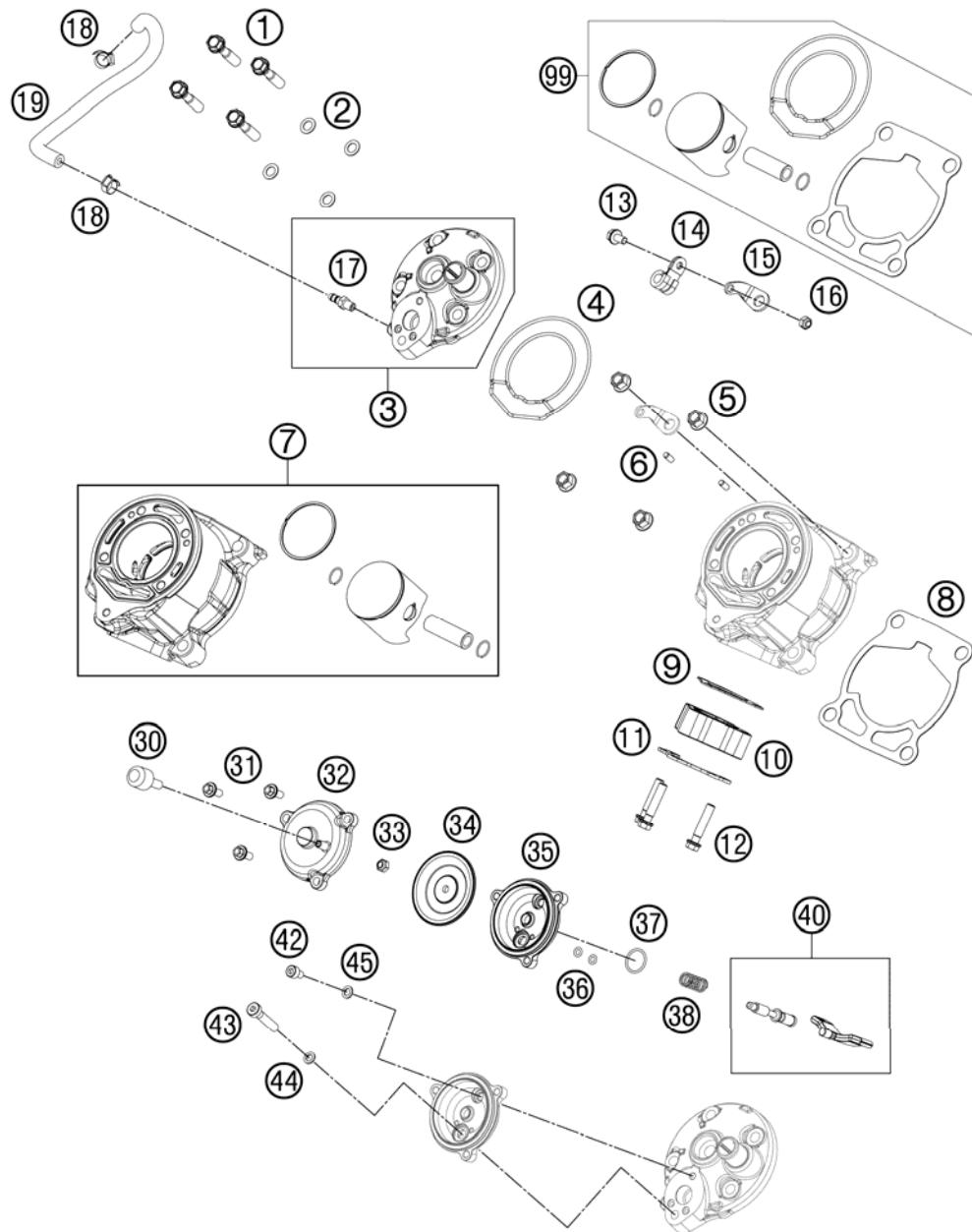

FIG	PART NUMBER	DESCRIPTION	QTY
45	0603050901	COPPERT GASKET 5X9X1	1
99	00050000202	PISTON KIT GR.I 65 SX 09-12	x
99	00050000203	PISTON KIT GR.II 65 SX 09-12	x

124623050 / C134623050

\* NEW PART

X AS REQUIRED

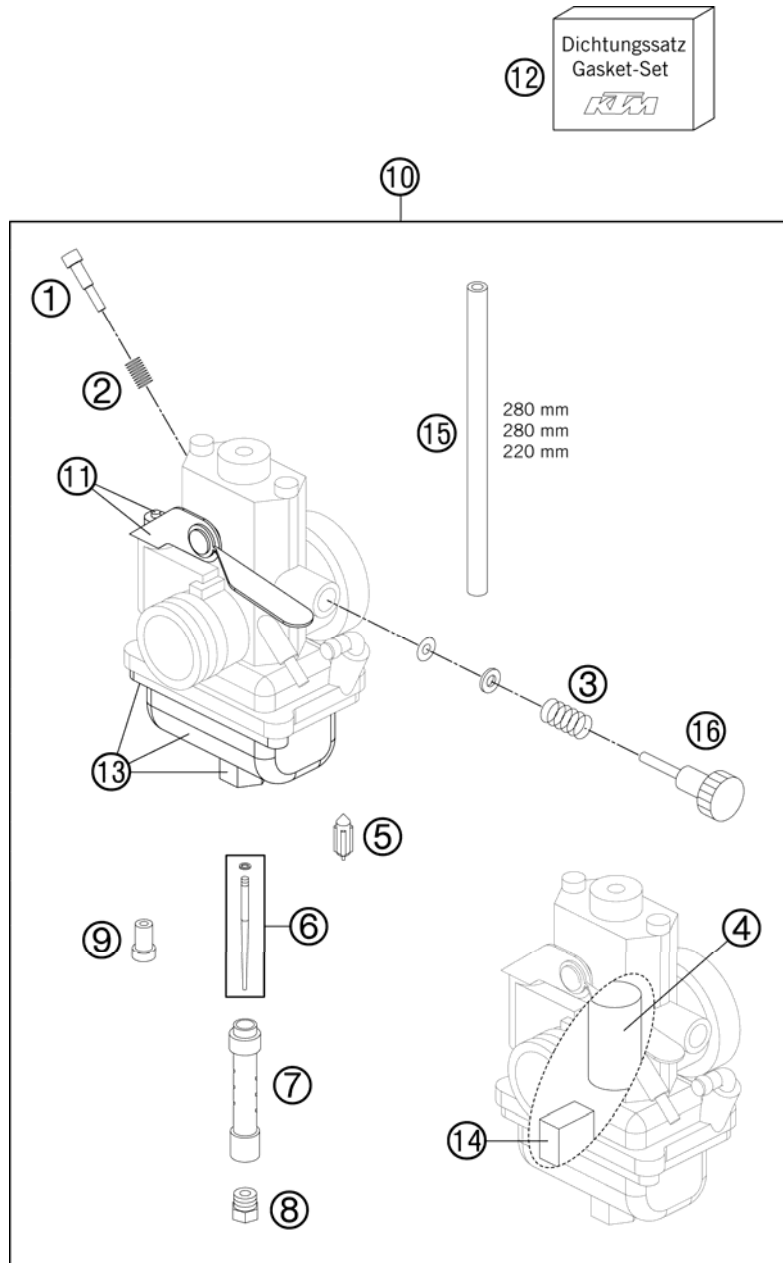

FIG	PART NUMBER	DESCRIPTION	QTY
1	46131017000	ADJUSTING SCREW MIKUNI	1
2	45031015200	SPRING IDLE ADJUST SCREW	1
3	45031015000	SPRING	1
4	46231035000	THROTTLE VALVE MIKUNI 2.5	1
5	46231020100	NEEDLE VALVE CPL. 2.5	1
6	46231034000	JET NEEDLE MIKUNI 5IPL43-2	1
7	46231034100	MAIN JET HOLDER MIKUNI	1
8	45031023195	MAIN JET 195	x
8	45031023200	MAIN JET 200	x
8	45031023205	MAIN JET 205	x
8	45031023210	MAIN JET 210	x
8	45031023215	MAIN JET 215	x
8	45031023220	MAIN JET 220	x
8	45031023225	MAIN JET 225	x
8	45031023230	MAIN JET	x
9	45031007000	IDLING JET	x
9	45031007010	IDLE JET 10 MIKUNI	x
9	45031007015	IDLING JET 15 MIKUNI	x
9	45031007020	IDLING JET 20 MIKUNI	x
9	45031007025	IDLING JET 25 MIKUNI	x
10	46231001144	CARBURETOR 65 SX 2011	1
11	46231048044	CHOKE + LEVER CPL.	1
12	46231099000	GASKET SET MIKUNI	1
13	46231011044	FLOAT BODY + SCREW + GASKET	1
14	46231009044	FLOAT + PIN	1
15	52031137001	PVC-HOSE 3X5MM	1
16	46231094000	ADJUSTER SCREW	1

124623110 / C134623110

\* NEW PART

X AS REQUIRED

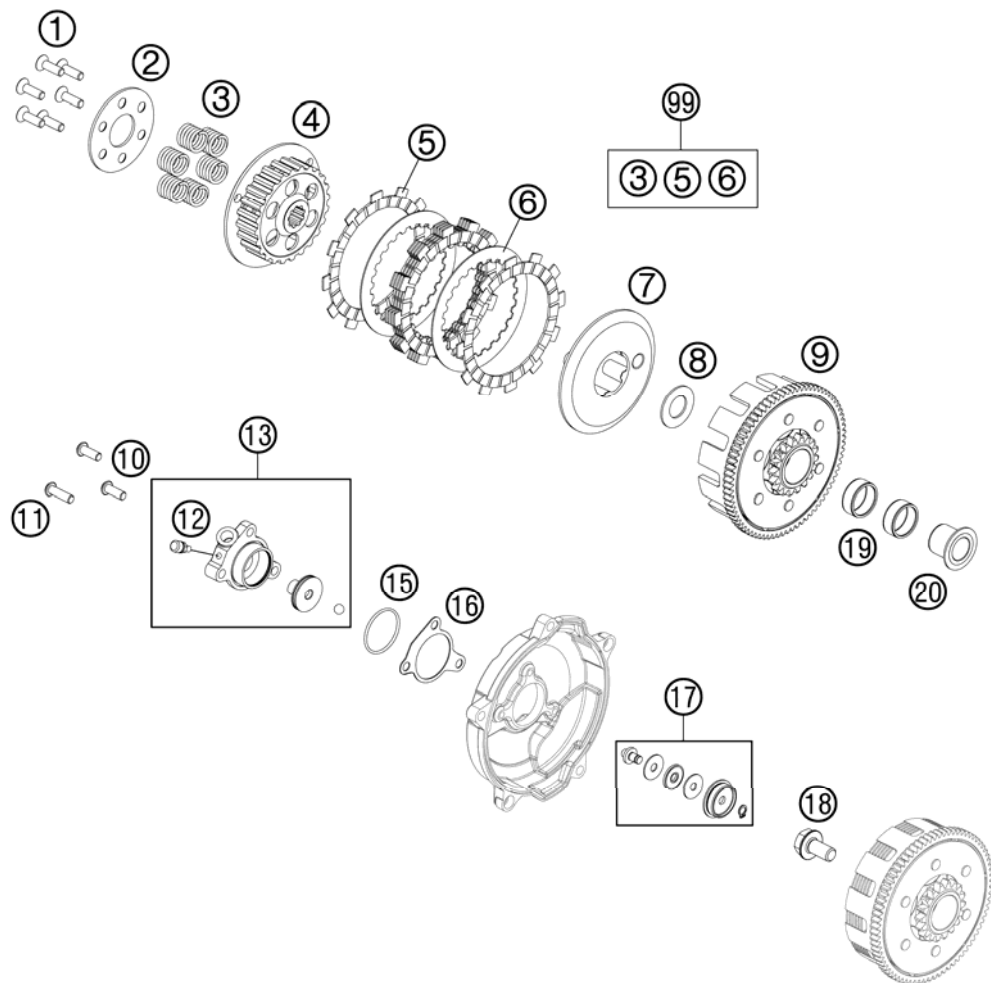

FIG	PART NUMBER	DESCRIPTION	QTY
1	0991060202	FLAT HEAD DIN7991-M 6X20	6
2	46032006000	SPRING RETAINER 25X63,5X2	1
3	46232005044	CLUTCH SPRING KIT	1
4	46232002000	CLUTCH HUB	1
5	46032011044	LINING DISK KIT	1
6	46032010000	INTERMEDIATE DISK STEEL	5
7	46232003000	CLUTCH PRESSURE CAP	1
8	46232012000	STOP DISC 17,2X32X1,5	1
9	46232000044	PRIMARY DRIVE WITH CLUTCH CAGE	1
10	0738060161	FLAT HEAD SCREW ISO7380 M6X16	2
11	0738060201	FLAT HEAD SCREW ISO7380 M6X20	1
12	54732064000	BLEEDER SCREW WITH CAP	1
13	75032061044	OUTPUT CYL. WITH BLEEDER SCREW	1
15	0770300015	O-RING 30,00X1,50 NBR 70	1
16	59032065000	GASKET FOR SLAVE CYLINDER	1
17	46232057000	PRESSURE PIECE CPL.	1
18	46132019000	HH COLLAR SCREW M10X20	1
19	0405222610	% NEEDLE BEARING K 22X26X10 A	2
20	46232015000	INNER RING WITH COLLAR	1
99	46232010010	CLUTCH KIT 65 SX 09-12	1

124623210 / C134623210

\* NEW PART

X AS REQUIRED

# TRANSMISSION

65 SX 2013

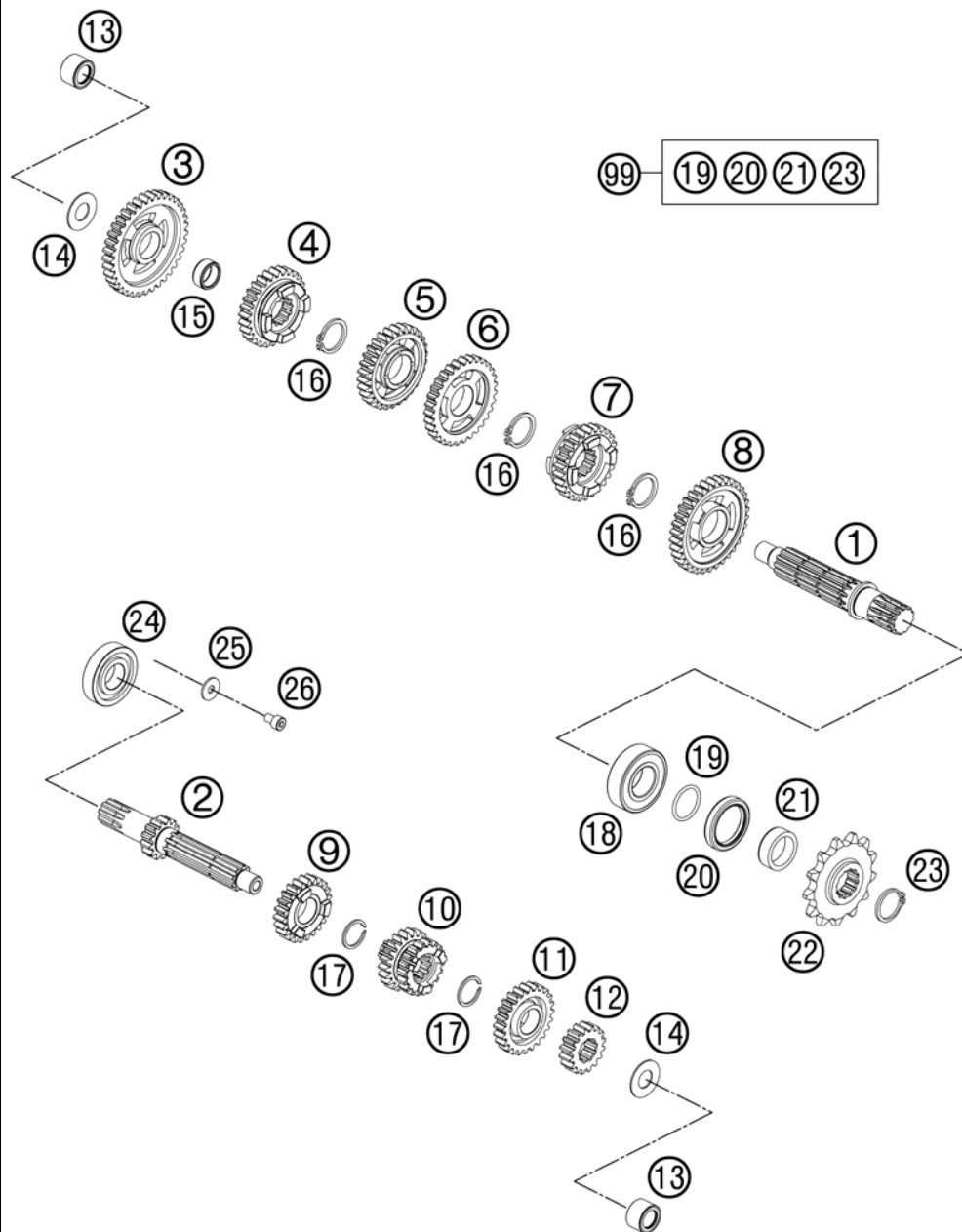

FIG	PART NUMBER	DESCRIPTION	QTY
1	46233010000	COUNTERSHAFT	1
2	46233001000	MAIN SHAFT 13-T	1
3	46233011000	IDLER GEAR 1.G.	1
4	46233015000	SLIDING GEAR 5.G.	1
5	46233014000	IDLER GEAR 4.G.	1
6	46233013000	IDLER GEAR 3.G.	1
7	46233016000	SLIDING GEAR 6.G.	1
8	46233012000	IDLER GEAR 2.G.	1
9	46233005000	IDLER GEAR 5.G.	1
10	46233003000	SLIDING GEAR 3/4. G	1
11	46233006000	IDLER GEAR 6.G.	1
12	46233002000	SOLID GEAR 2.G	1
13	0618121912	NEEDLE BUSH NK1212	2
14	49033013000	STOP DISK 12,1X25X1	2
15	46033020000	NEEDLE BEARING 14X18X8	1
16	49033091000	CIRCLIP AS20X1,75	3
17	46233022000	LOCK RING	2
18	46033028000	GROOVED BALL BEARING 20X42X12	1
19	0770020020	O-RING 20X2 VITON	1
20	0760263561	SHAFT SEAL RING 26X35X6BSL NB	1
21	46233030000	DISANCEPACER F. SPROCKET	1
22	46233029013	CHAIN SPROCKET 13-T.	x
22	46233029014	CHAIN SPROCKET 14-T.	1
23	49033091000	CIRCLIP AS20X1,75	1
24	0625982030	BALL BEARING 98203 KSE C3	1
25	0021050003	WASHER DIN9021-A 5,3	1
26	0912050083	AH SCREW DIN 912 M 5X8	1
99	00050000947	COUNTER SHAFT REP.KIT 65 SX	x

124623310 / C124623310

\* NEW PART

X AS REQUIRED

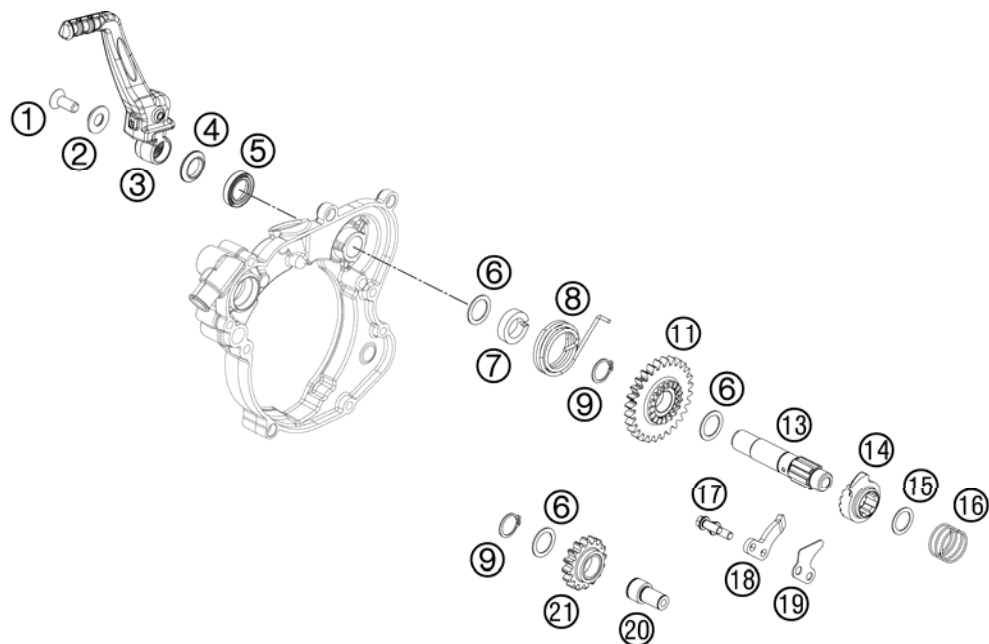

FIG	PART NUMBER	DESCRIPTION	QTY
1	0019080206	COUNTER-SUNK SCREW ISA45 M8X20	1
2	54633037000	WASHER 8MM GALVANIZED	1
3	46233036044	KICKSTARTER CPL.	1
4	46233038000	SPACER SLEEVE	1
5	0760172860	SHAFT SEAL RING 17X28X6B NBR	1
6	50333030000	STOP DISK 17,2X24X1	3
7	50333055000	DRIVING HUB 125/200'98	1
8	50333054000	KICKSTARTER SPRING 2,6MM '98	1
9	0471170010	CIRCLIP DIN0471-17X1	2
11	77033051000	KICKSTART. GEAR 28-T 05	1
13	50333050000	KICKSTARTER SHAFT 125/200'98	1
14	50333052000	KICKSTARTER RATCHET	1
15	0988162210	THRUST WASHER DIN0988-16X22X1	1
16	50333056000	SPRING 1,4MM '98	1
17	0025060166	HH COLLAR SCREW M6X16 TX30	2
18	50333069000	STOP MET.SHEET 4MM 125/200'98	1
19	46233069001	COVER PLATE	1
20	46233018000	BEARING PIN IDLER GEAR	1
21	46233053016	INTERMEDIATE STARTING GEAR	1

124623390 / C134623390

\* NEW PART

X AS REQUIRED

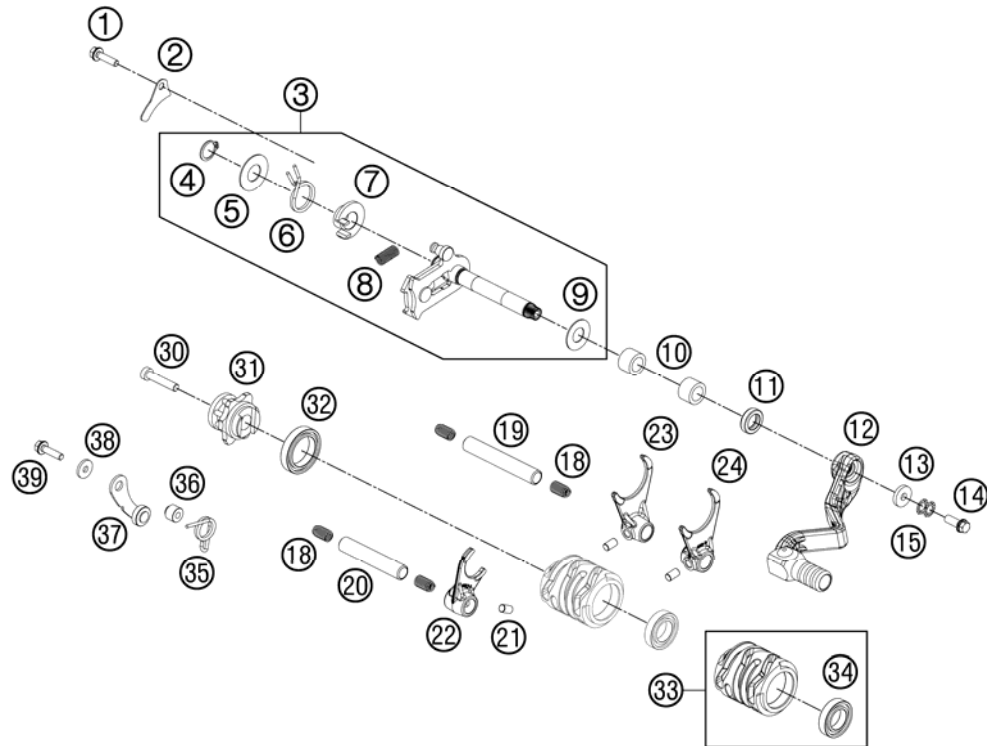

FIG	PART NUMBER	DESCRIPTION	QTY
1	0025050126	HH COLLAR SCREW M5X12 TX30	1
2	46234005110	SHIFTING SHAFT FENDER RET. PL.	1
3	46234005044	SHIFT SHAFT CPL.	1
4	0471140100	LOCK WASHER DIN0471-14X1	1
5	54634050000	STOP DISK 14X30X1	1
6	54834014000	RETURN SPRING 03	1
7	54634020000	SPRING GUIDE	1
8	56534013100	TENSIONING SPRING 0,8MM	1
9	49033013000	STOP DISK 12,1X25X1	1
10	46034027000	NEEDLE BEARING 12X18X12 2002	2
11	0760122050	SHAFT SEAL RING 12X20X5 B	1
12	46234031044	SHIFTING LEVER CPL.	1
13	50232050001	STEEL WASHER 6,4X17X3	1
14	59009062016	SPECIAL SCREW M6X16 WS=8 10.9	1
15	50233041000	PAIR OF WASHERS M 6 NORDLOCK	2
18	58038023200	PRESSURE SPRING 0,9MM	4
19	46234019000	SHIFTING RAIL COUNTER SHAFT	1
20	46234020000	SHIFTING RAIL MAIN SHAFT	1
21	0402061000	NEEDLE ROLLER ZRB 6X10	3
22	46234001000	SHIFT FORK MAIN SHAFT	1
23	46234002000	SHIFT FORK COUNTERSHAFT R/S	1
24	46234003000	SHIFT FORK COUNTERSHAFT LI/S	1
30	0912060303	AH SCREW DIN0912-M 6X30	1
31	46234015044	SHIFT DRUM LOCATING CPL.	1
32	0625618050	BALL BEARING 61805 C3	1
33	46234012033	SHIFT ROLLER CPL.	1
34	0625069034	BALL BEARING 6903 C4	1
35	54834023000	LOCKING LEVER SPRING 03	1
36	54634052300	SLEEVE FOR LOCKING LEVER	1
37	50334024144	LOCATING LEVER CPL. 08	1
38	03490000050	WASHER DIN7349-5X15X2	1
39	0025050206	HH COLLAR SCREW M5X20 TX30	1

124623410 / C134623410

\* NEW PART

X AS REQUIRED

# WATER PUMP

65 SX 2013

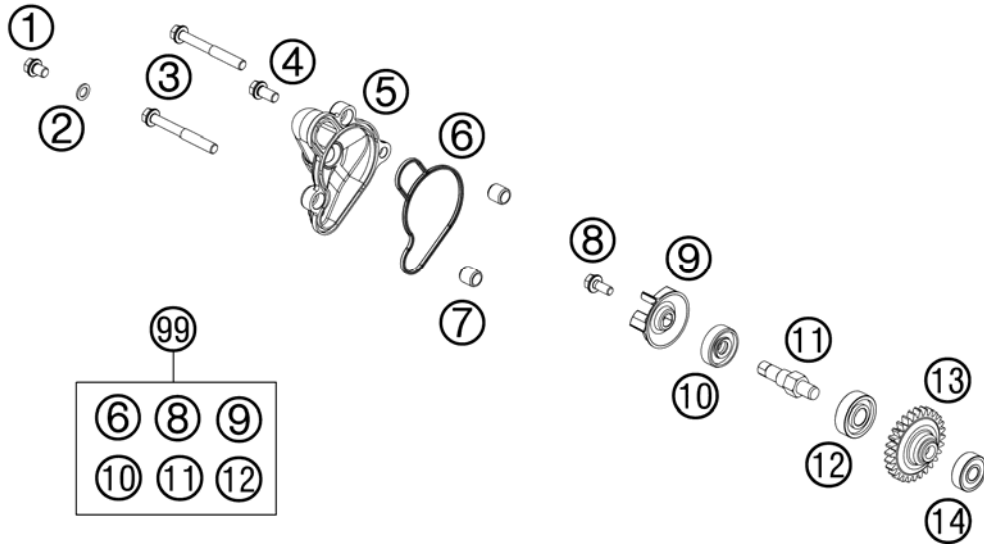

FIG	PART NUMBER	DESCRIPTION	QTY
1	0025060086	HH COLLAR SCREW M6X8 TX30	1
2	0603061001	CU-SEAL RING DIN7603-6X10X1	1
3	0025060506	HH COLLAR SCREW M6X50 TX30	2
4	0025060126	HH COLLAR SCREW M6X12 TX30	1
5	45235052000	WATERPUMP COVER	1
6	45235053000	WATER PUMP COVER GASKET	1
7	49030090000	DOWEL 9,8 X 7 X 10	2
8	0014050123	HH COLLAR SCREW M 5X12 WS=6	1
9	54835005000	WATER PUMP WHEEL 07	1
10	0760082472	SHAFT SEAL RING 8X24X7 A DUO	1
11	50335054150	WATER PUMP SHAFT	1
12	0625060001	BALL BEARING 6000/C3	1
13	45235054028	DRIVE WHEEL	1
14	0625006087	GROOVED BALL BEAR. 608 2RS C3	1
99	54835055010	WATER PUMP REP. KIT 50/65 SX	1

124623510 / C124623510

\* NEW PART

X AS REQUIRED



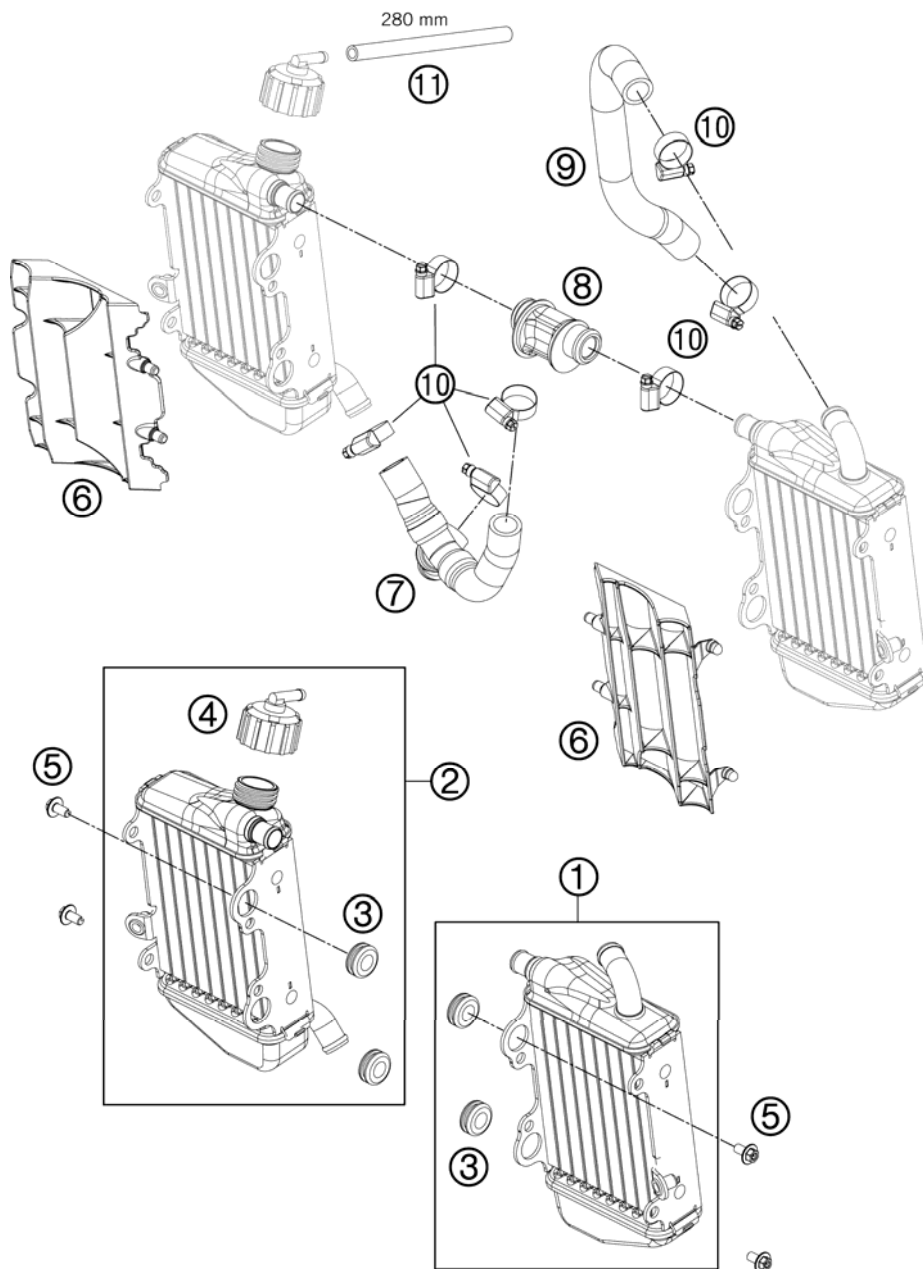

FIG	PART NUMBER	DESCRIPTION	QTY
1	46235007000	RADIATOR L/S 65 SX 2009	1
2	46235008000	RADIATOR R/S 65SX 2009	1
3	41001052000	RUBBER SLEEVE D=12MM	4
4	45135009000	RADIATOR CAP 50 LC 1,0 BAR	1
5	0024060123	COLLAR SCREW M6X12 TX	4
6	46235034000	RADIATOR PROTECTOR 65 SX 2009	2
7	46235025033	RADIATOR HOSE CPL.+Y-CONNECT.	1
8	46235025000	RADIATOR CONNECTOR TOP	1
9	46235022000	PREFORMED HOSE 65SX RAD.L/S	1
10	42013037400	HOSE CLAMP NORMA 12/24	7
11	55007016001	PVC-HOSE 7X10 PER METER	x

124623530 / C134623530

\* NEW PART

X AS REQUIRED

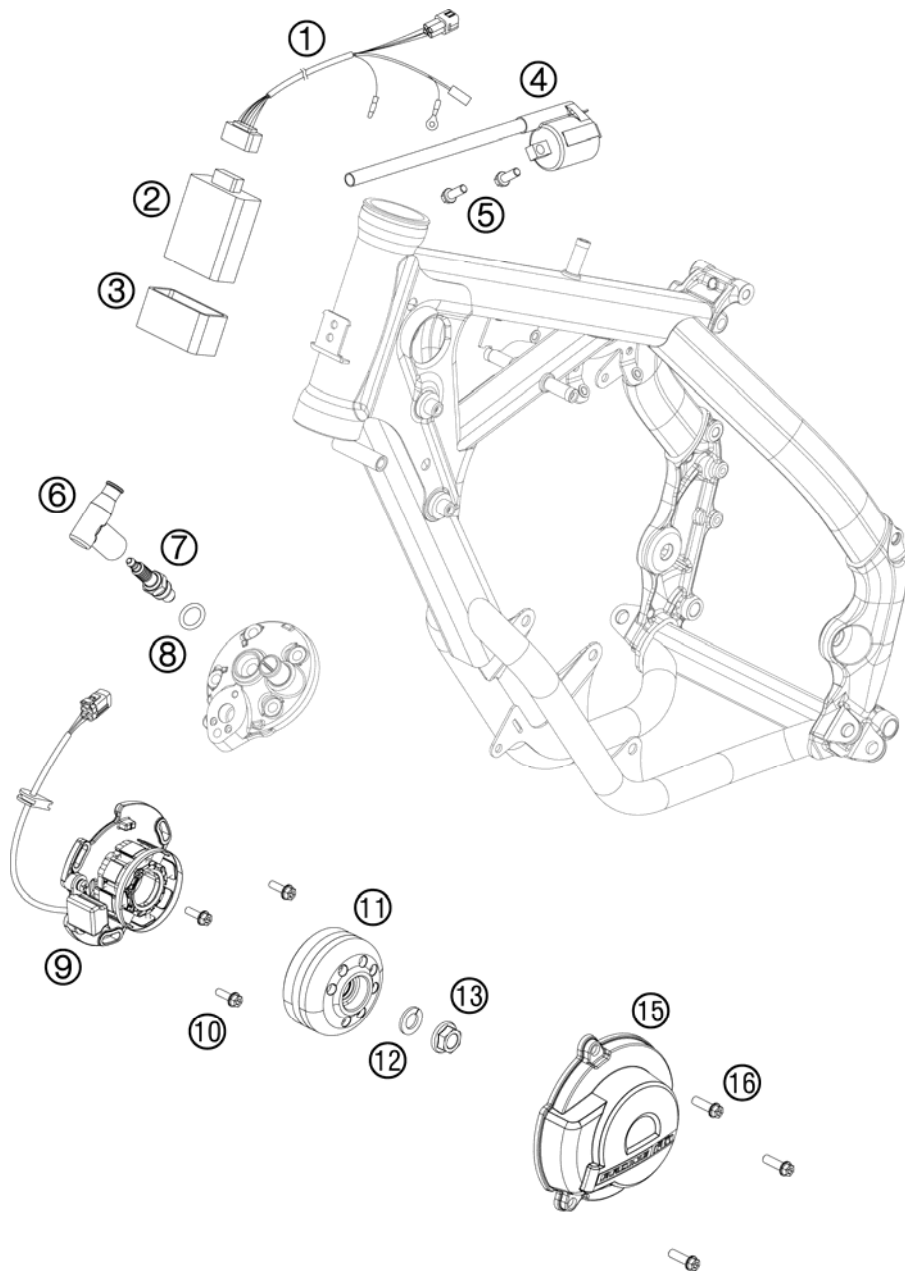

FIG	PART NUMBER	DESCRIPTION	QTY
1	46239095000	WIRING HARNESS CDI 65 SX 2009	1
2	46239031000	CDI 65 SX 2009	1
3	46139030000	RUBBER BR. DIGI.BOX 65SX 2003	1
4	59039006000	IGNITIONCOIL "IG5128"	1
5	0025060166	HH COLLAR SCREW M6X16 TX30	2
6	46239090000	SPARK PLUG CONNECTOR	1
7	45239093000	SPARK PLUG LR8B	1
8	0770012030	O-RING 12,00X3,0 VITON 75	1
9	46239004000	STATOR	1
10	0025050166	HH COLLAR SCREW M5X16 TX30	3
11	46239005000	ROTOR	1
12	50230029012	LOCKING RING VSK 12	1
13	49030021000	COLLAR NUT M12X1 R/S	1
15	46230002100	IGNITION COVER	1
16	0025060206	HH COLLAR SCREW M6X20 TX30	3

124623910 / C124623910

\* NEW PART

X AS REQUIRED





KTM-Sportmotorcycle AG  
A-5230 Mattighofen  
[www.ktm.at](http://www.ktm.at)

KTM Group Partner



3CM080208MEN



Art.Nr.: 3CM080208MEN 4/2012