

# 250 EXC-F SIX DAYS EU 2013

SPARE PARTS MANUAL: CHASSIS

ART.NO.: 3CFF8103M2EN

ENGLISH



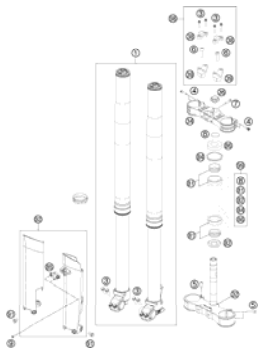
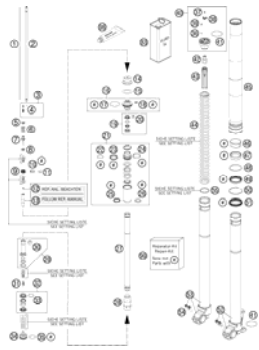
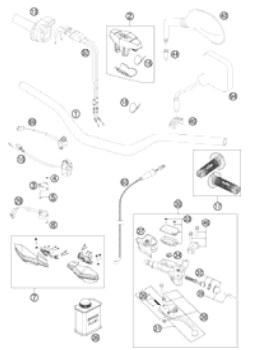
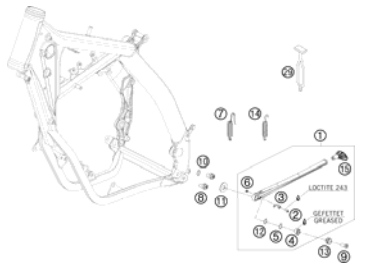
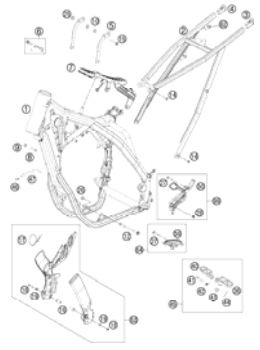
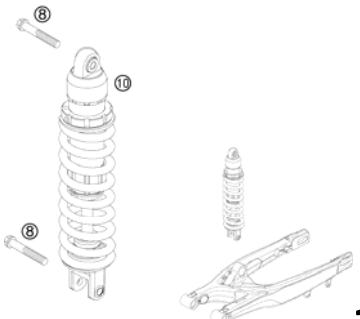
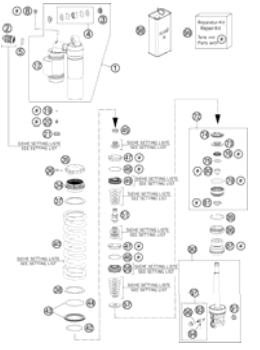
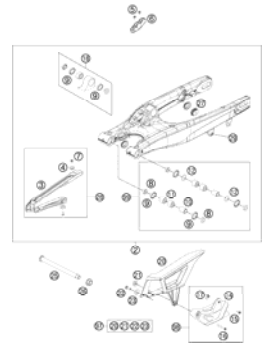
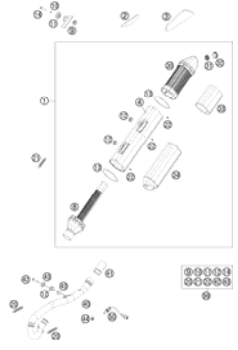
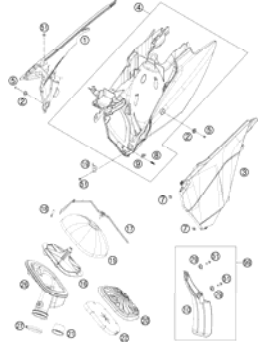
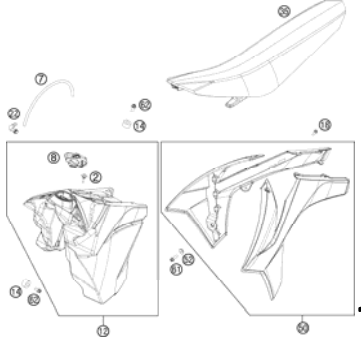
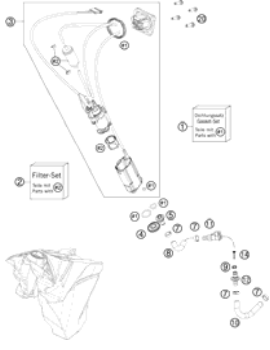

<p><b>FRONT FORK, TRIPLE CLAMP</b></p>  <p><b>4</b></p>	<p><b>FRONT FORK DISASSEMBLED</b></p>  <p><b>5</b></p>	<p><b>HANDLEBAR, CONTROLS</b></p>  <p><b>8</b></p>	<p><b>SIDE / CENTER STAND</b></p>  <p><b>9</b></p>
<p><b>FRAME</b></p>  <p><b>10</b></p>	<p><b>SHOCK ABSORBER</b></p>  <p><b>12</b></p>	<p><b>SHOCK ABSORBER DISASSEMBLED</b></p>  <p><b>13</b></p>	<p><b>SWING ARM</b></p>  <p><b>15</b></p>
<p><b>EXHAUST SYSTEM</b></p>  <p><b>16</b></p>	<p><b>AIR FILTER</b></p>  <p><b>17</b></p>	<p><b>TANK, SEAT, COVER</b></p>  <p><b>18</b></p>	<p><b>FUEL PUMP</b></p>  <p><b>19</b></p>

**MASK, FENDERS**

**20**

**DECAL**

**21**

**FRONT WHEEL**

**22**

**REAR WHEEL**

**23**

**WIRING HARNESS**

**25**

**BRAKE CALIPER REAR**

**26**

**HAND BREAK CYLINDER**

**27**

**BRAKE CALIPER FRONT**

**28**

**REAR BRAKE CONTROL**

**29**

**LIGHTING SYSTEM**

**30**

**INSTRUMENTS / LOCK SYSTEM**

**31**

**ACCESSORIES KIT**

**32**

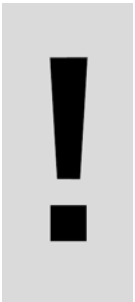
		<p>All information contained is without obligation. KTM-Sportmotorcycle AG particularly reserves the right to modify any equipment, technical specifications, prices, colors, shapes, materials, services, service work, constructions, equipment and the like so as to adapt them to local conditions or to cancel any of the above items, all without previous announcement and without giving reasons. KTM may stop manufacturing certain models without previous notice. KTM shall not be held liable for any deviations of availability and/or ability to deliver, illustrations, descriptions, printing and/or other errors. The illustrated models partly contain extra equipment, which is not applied to standard models. © by KTM-SPORTMOTORCYCLE AG, Mattighofen AUSTRIA; All rights reserved; Reprint, also in extracts, with written allowance of KTM-SPORTMOTORCYCLE AG, Mattighofen only.</p>	

# FRONT FORK, TRIPLE CLAMP

250 EXC-F SIX DAYS EU 2013

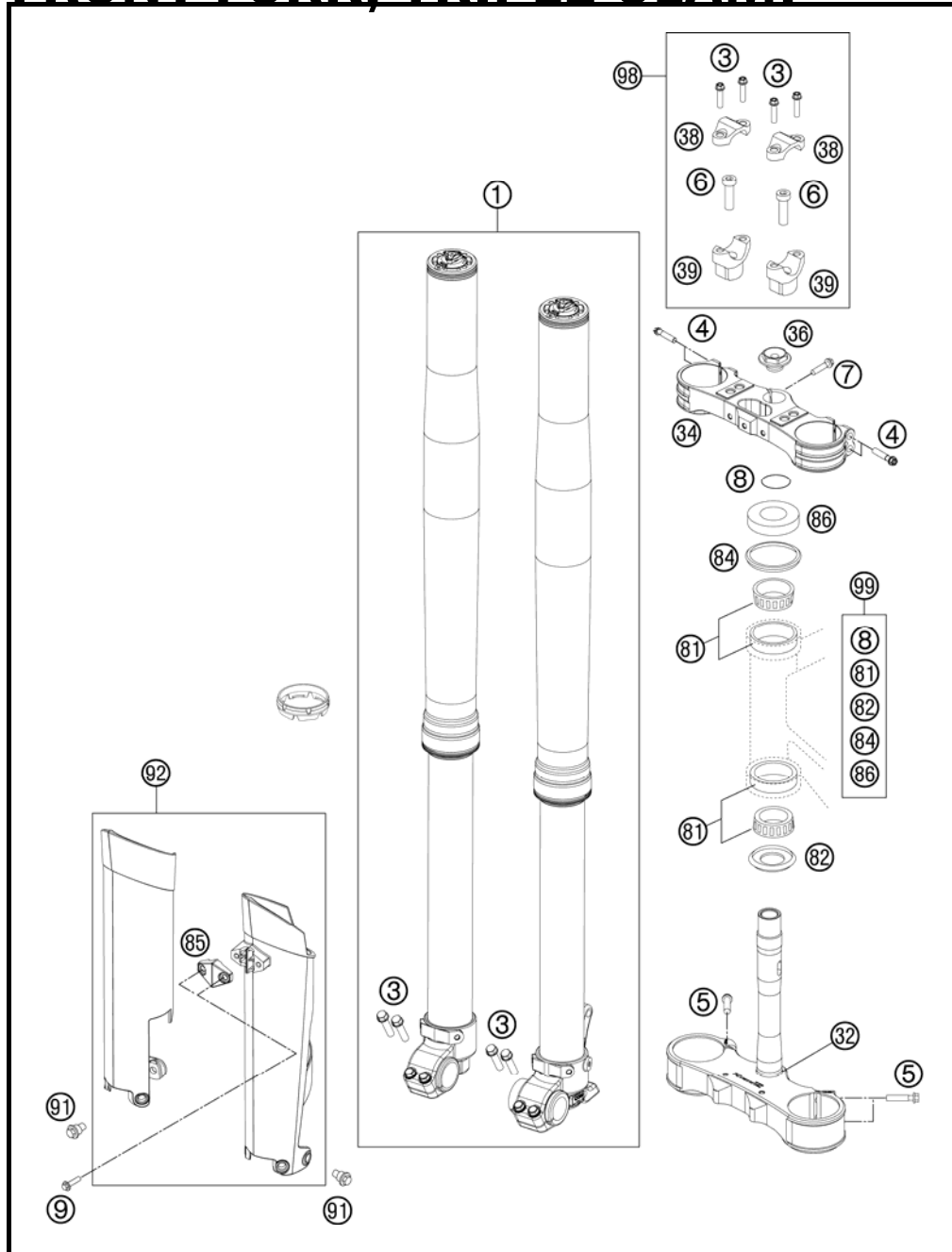

FIG	PART NUMBER	DESCRIPTION	QTY
1*	24187M6301	FORK WP 250/300 TE, 250 FE	1
3	0025080256	HH COLLAR SCREW M8X25 TX40	8
4	0025080406	HH COLLAR SCREW M8X40 TX40	4
5	0025080356	HH COLLAR SCREW M8X35 TX40	4
6	0032100356S	AH-COLLAR SCREW M10X35 ISA45	2
7	0025080256S	HH COLLAR SCREW M8X25 TX40	1
8	0770025035	O-RING 25X3,55 NBR70 05	1
9	0017060204	EJOT PT SCREW K60X20 ALU WS=6	2
10	SXS08125610	BLEEDER VALVE SET	1
32	7800103202004	BOT.TRIPLE CLAMP CPL. 20MM OR.	1
34	7720103402004	TOP TRIPLE CLAMP X=20MM ORANGE	1
36	54801036000	STEER.HEAD SCREW M20X1,5 WS=27	1
38	77201038000	HANDLEBAR CLAMP 28MM	2
39	59401039032	HANDLEB.SUPP. D=28MM H=32MM 05	x
39	59401039037	HANDLEB.SUPP. D=28MM H=37MM 05	2
39	59401039042	HANDLEB.SUPP. D=28MM H=42MM 05	x
81	54201081100	TAPERED ROLLER BEARING CPL. 06	2
82	54601084100	O-RING SUPPORT W. SEALING LIP	1
84	54601184000	STEERING HEAD GASKET TOP	1
85	7800108500028	CLAMP F. SPEED. CABLE D=6MM 08	1
86	78101086000	STEERING HEAD COVER	1
91	59001092050	SPECIAL SCREW M6X12,5 WS=8	6
92	7800109410028	FORK PROTECT. L/S+R/S WHITE 09	1
98	00050000921	HANDLEBAR SUPPORT KIT D28/H37	x
99	00050000930	STEERING HEAD REP. KIT	x

137700111 / C137700110

\* NEW PART

X AS REQUIRED

# FRONT FORK DISASSEMBLED

250 EXC-F SIX DAYS EU 2013

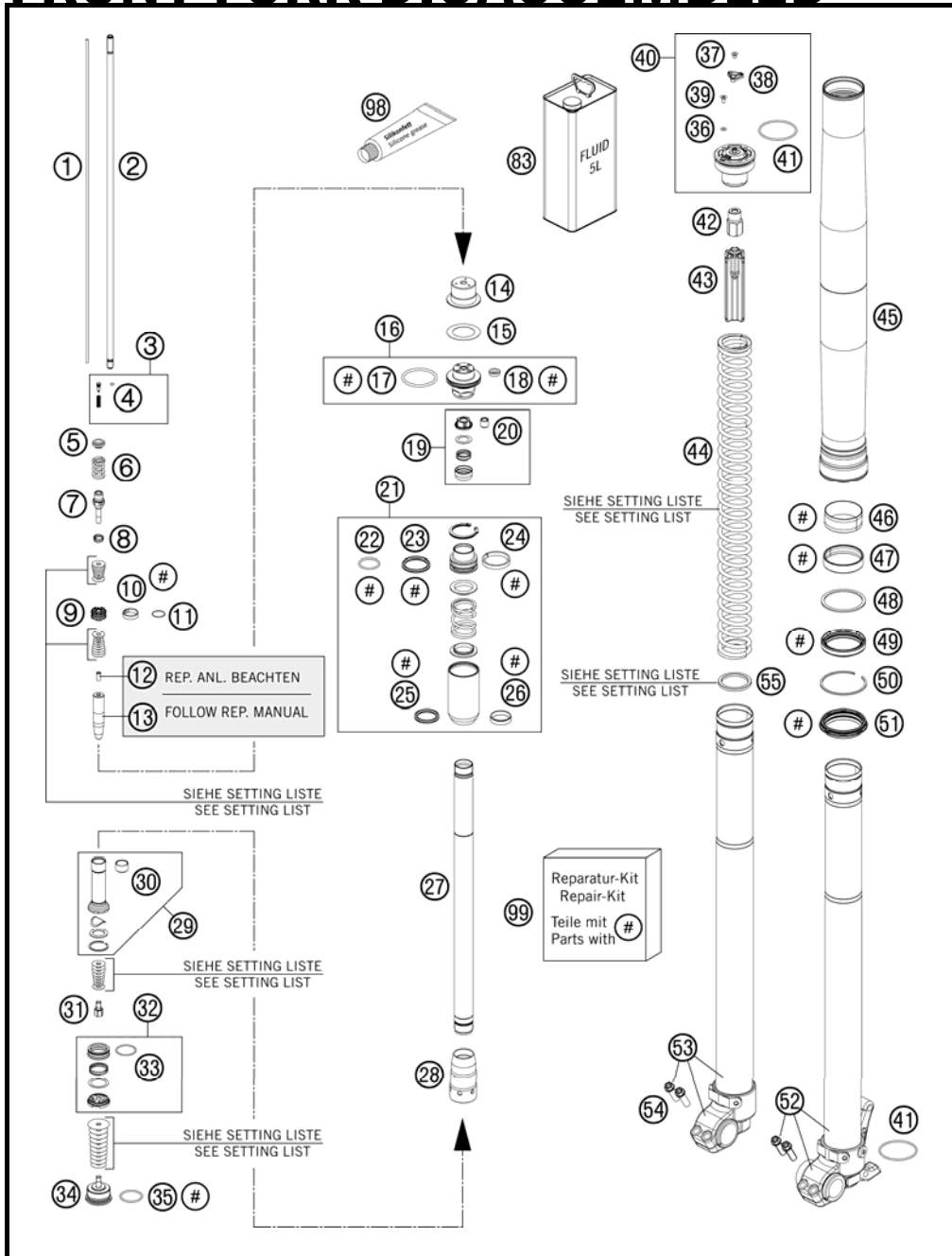

FIG	PART NUMBER	DESCRIPTION	QTY
1*	48600996	ADJUSTMENT TUBE L486 OD3	2
2*	48601054	PISTON ROD D8 L497	2
3*	48600998S	ADJ - NEEDLE CPL.	2
4	48600298	O-RING 2X1,5 NBR	2
5*	48601048	GUIDE SHIM REBOUND SPRING	2
6*	48601049	REBOUND SPRING L25	2
7*	48600986	TAP REBOUND M8	2
8	48600382	SHUTTLE VALVE SPRING C=0,4	2
9*	48600985	PISTON REBOUND D20	2
10*	48601171	Z-CUT RING D18 PLASTIC	2
11*	48601128	O-RING 15X1	2
12*	48601033	PUSHER D=5,5	2
13*	48600999	FOLLOW REPAIR MANUAL NEEDLE D14 WHITE L/S	1
13*	48601123	NEEDLE D14 RED R/S	1
14*	48601061	SPRING GUIDANCE BELOW	2
15*	48601184	SHIM 29X44X0,3	2
16*	48601022S	SCREW SLEEVE M23,5 CPL.	2
17*	48601130	O-RING 40X3	2
18*	48600954	GASKET D8	2
19*	48601025S	CHECK VALVE D21 CPL.	2
20*	48600953	GUIDING BUSH 8X10X10	2
21*	48601021S	PRESSURE TANK L74,5 D36 KPL.	2
22*	48601127	O-RING 24x2	2
23*	48601111	QUAD RING 29,74X3,53	2
24*	48601124	BUSHING DO=36 DI=32 B5	2
25*	48601110	QUAD RING 24,99X3,53	2
26*	48601109	SLIDE BEARING	2
27*	48601031	TUBE D20 L403	2
28*	48601019	SCREW SLEEVE D20/28	2
29*	48601030S	STOP L75	2
30*	48601180	BUSHING	2
31*	48601083	NUT M6X0,5	2

138120130 / C138120130

\* NEW PART

X AS REQUIRED

# FRONT FORK DISASSEMBLED

250 EXC-F SIX DAYS EU 2013

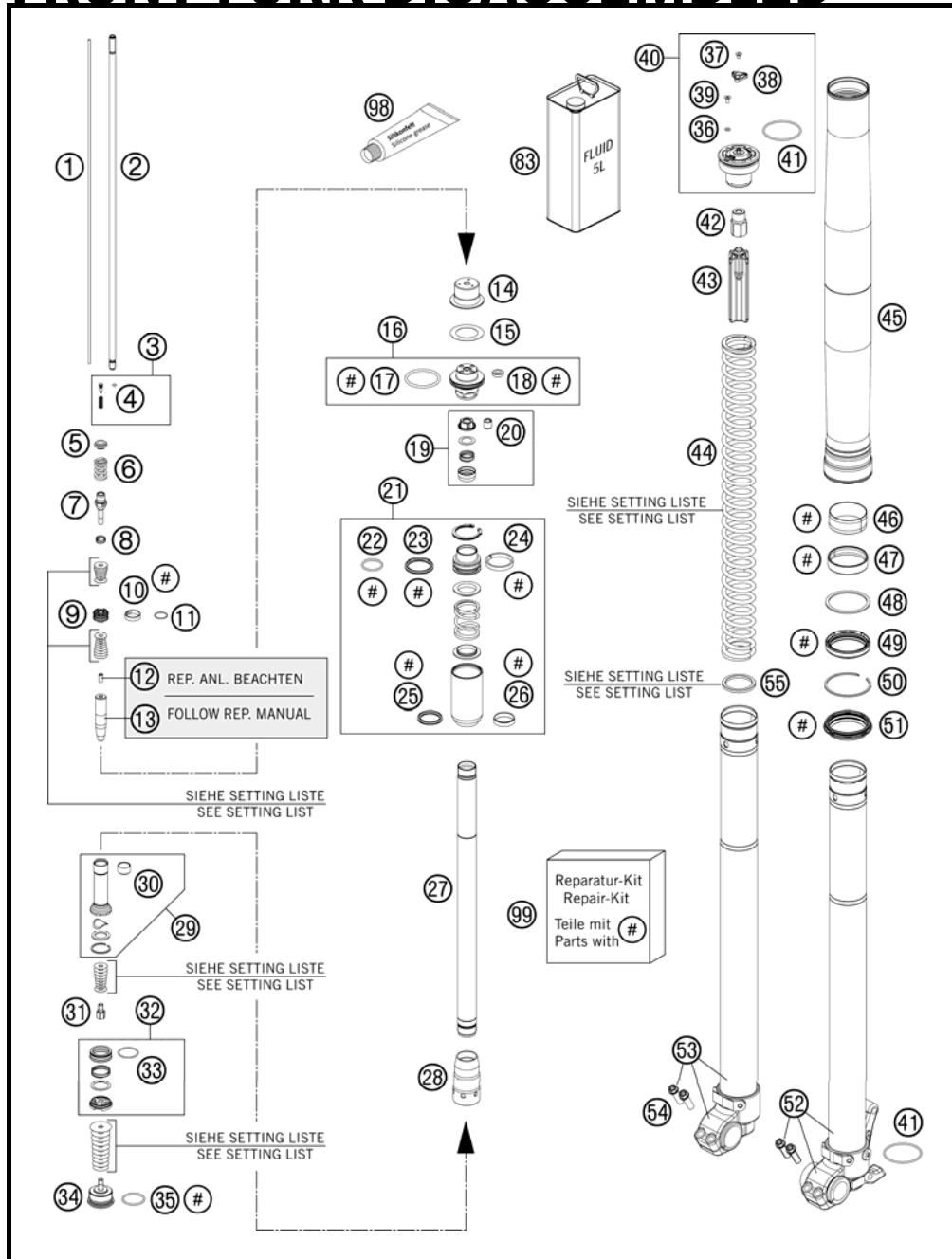

FIG	PART NUMBER	DESCRIPTION	QTY
32*	48600984S	PISTON COMPRESSION D=28 CPL.	2
33*	48601133	O-RING 24X1,5	2
34*	48601020	SCREW CAP M30	2
35*	48601132	O-RING 26X2	2
36	50180222	O-RING NBR 4X1,5	2
37*	48600527	AH SCREW M4X6	2
38*	48601117	DIAL COMPRESSION WHITE L/S, COMPRESSION	1
38*	48601118	DIAL REBOUND RED R/S, REBOUND	1
39	48600481	VENT SCREW M4X8	2
40*	48601050S	SCREW CAP M51X1,5 REB. KPL. R/S, REBOUND, RED	1
40*	48601116S	SCREW CAP M51X1,5 COMP. KPL. L/S, COMPRESSION, WHITE	1
41	48600048	O-RING NBR 46 X 2	4
42*	48601034	COUNTERNUT M8	2
43*	48601035	SPRING GUIDANCE D23	2
44*	91410082S	SPRING D43,8 L465 3,8N/MM SET	x
44*	91410083S	SPRING D43,8 L465 4,0N/MM SET	x
44*	91410084S	SPRING D43,8 L465 4,2N/MM SET	x
44*	91410085S	SPRING D43,8 L465 4,4N/MM SET	x
44*	91410086S	SPRING D43,8 L465 4,6N/MM SET	x
44*	91410092S	SPRING D43,8 L465 4,8N/MM SET	x
45	48600736	OUTER TUBE L577 D54/60MM 2L	2
46	48601008	GUIDING BUSH 47X49X20 R11	2
47	48601009	GUIDING BUSH 48X52X12 R11	2
48	48600013	SUPPORT RING 50 X 57,6 X 1,5	2
49*	48601179	OIL SEALRING D48X57,9X11,4 RED	2
50	48600070	LOCK WASHER SB58	2
51*	48601178	DUST SEAL DL48X58,4X5,7 RED	2
52*	48601028S1	AXLE CLAMP L/S WITH INNER TUBE	1
53*	48601029S1	AXLE CLAMP R/S WITH INNER TUBE	1
54*	0025080256	HH COLLAR SCREW M8X25 TX40	4
55*	48600456	SPACER 43X35X2,5	x

138120130 / C138120130

\* NEW PART

X AS REQUIRED





# FRONT FORK DISASSEMBLED

250 EXC-F SIX DAYS EU 2013

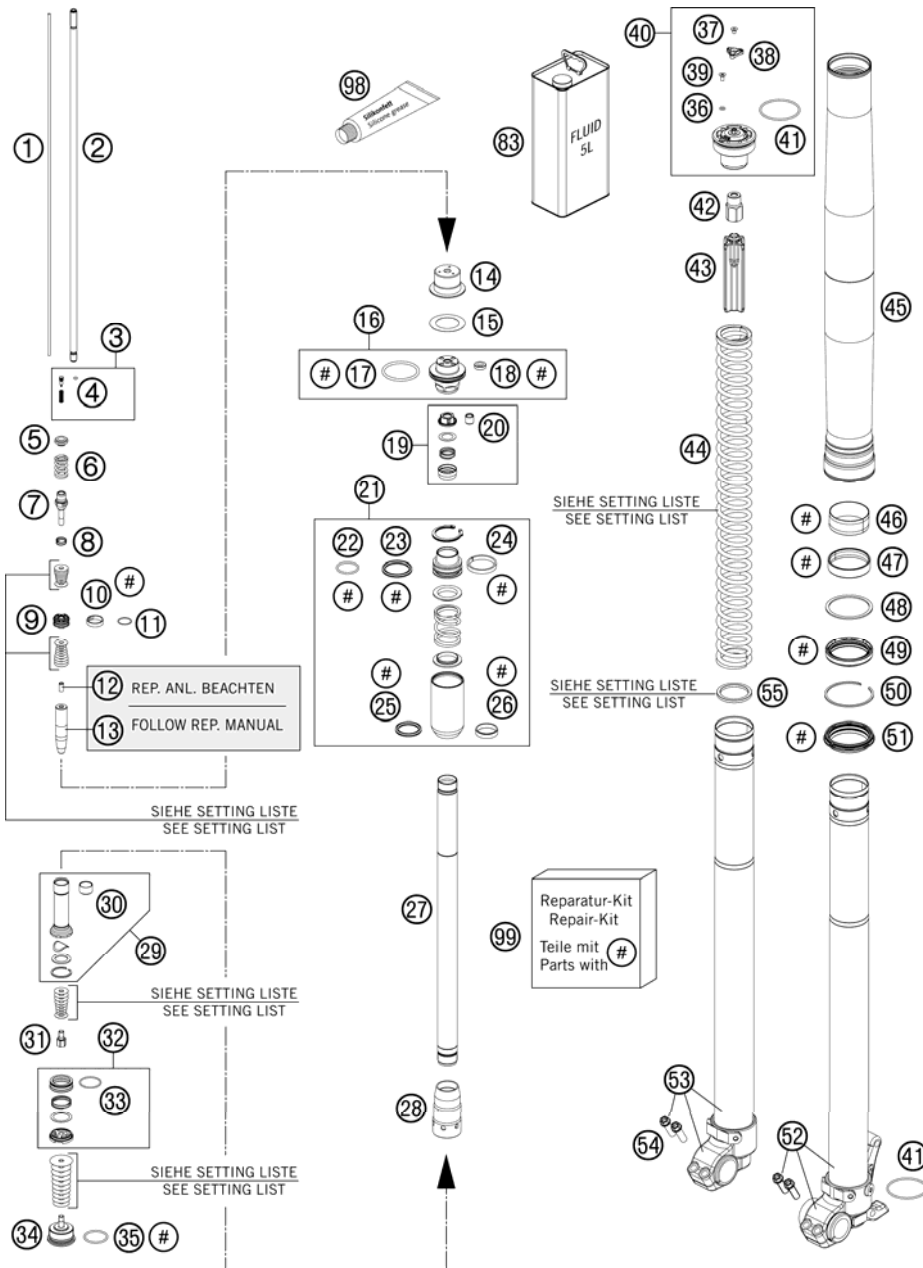

FIG	PART NUMBER	DESCRIPTION	QTY
55*	48600457	SPACER 43X35X5	X
55*	48600458	SPACER 43X35X1,5	X
83*	48601166S1	FORK OIL SAE4 5L	X
98	T511	SILICONE GREASE F. DUST STRI	X
99*	R24001	REPAIR - KIT	1

138120130 / C138120130

\* NEW PART

X AS REQUIRED

# HANDLEBAR, CONTROLS

250 EXC-F SIX DAYS EU 2013

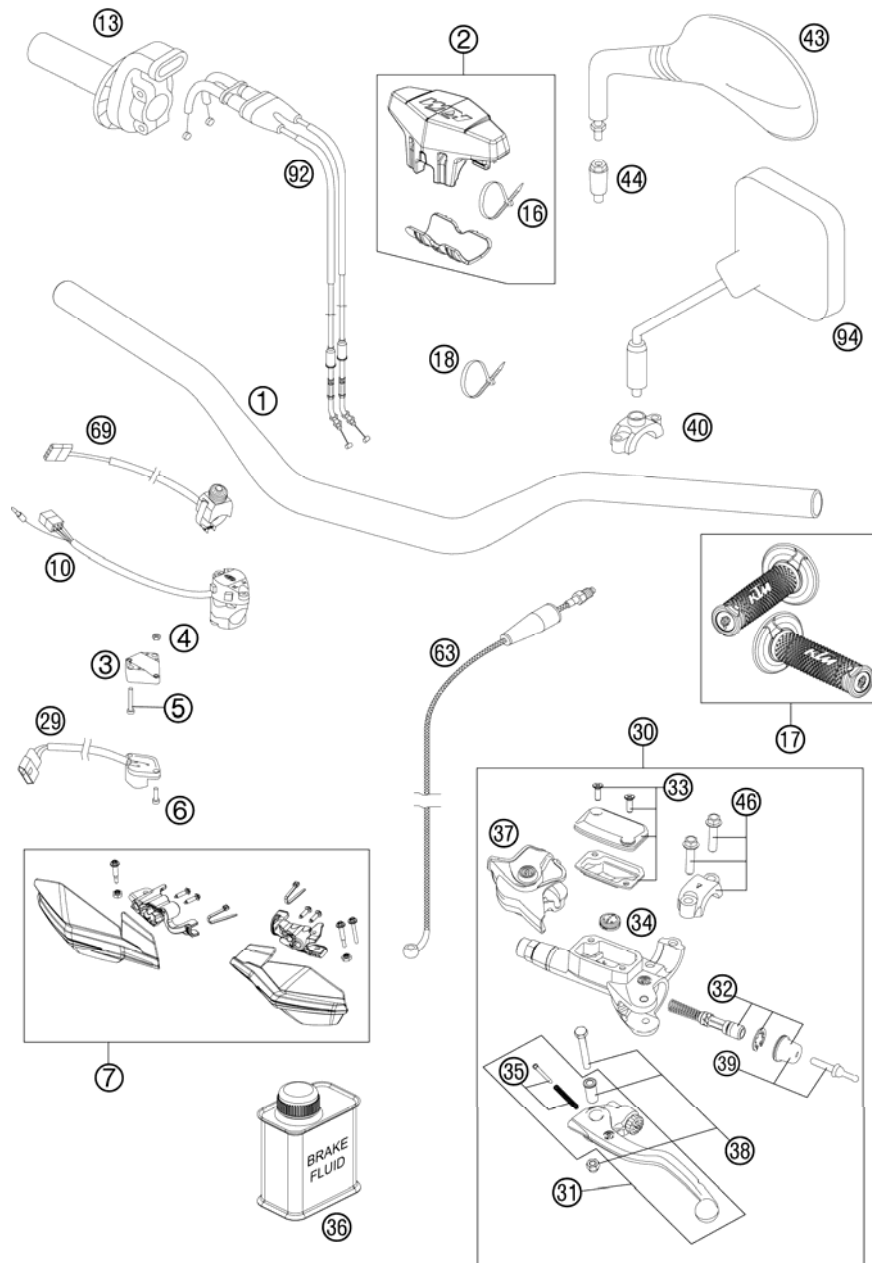

FIG	PART NUMBER	DESCRIPTION	QTY
1*	5480200130030	HANDLEBAR D=28MM SX/EXC BLACK	1
2	77202002144	BAR PAD CPL.	1
3	13011070060	ADAPTER FOR FLASHER SWITCH '98	1
4	0934040003	HEXAGON NUT DIN0934-M 4	2
5	0084040223	CYL.HEAD SCREW DIN0084-M 4X22A	2
6	0985040203	FLAT HEAD SCREW DIN7985-M 4X20	2
7*	7810297900028	HANDGUARDS CPL.LE+RI WHITE 12	x
10	50311070000	H.LIGHT SWITCH CEV 2/4TAKT '98	1
13*	78102010000	THROTTLE GRIP CPL.	1
16	44011076305	CABLE TIE 300/4,8MM BLACK	x
17*	78102021000	GRIP SET	1
18	44011076140	CABLE TIE 140/2,5MM BLACK	x
18	44011076200	CABLE TIE 200/3,6MM BLACK	x
29	50311029000	FLASHER SWITCH CEV '98	1
30	54802030044	MASTER CYLINDER CPL. 06	1
31	54802031000	CLUTCH LEVER CPL. BREMBO 06	1
32	54802032000	REP. KIT PISTON 06	1
33	54802003000	COVER HYD. CLUTCH CPL.	1
34	54802051000	VALVE	1
35	54802052000	BOLT KPL.	1
36	00062030000	BRAKE FLUID DOT5.1 0,25L	1
37	54802037000	PROTECTION CAP 06	1
38	54802038100	LEVER SCREW CPL. 06	1
39	54802046000	PUSH ROD CPL.	1
40	58012040150	CLAMP FOR MIRROR '94	2
43	58412040000	MIRROR L/S 98	x
43	58412041000	MIRROR R/S 98	x
44	58412040050	SUPPORT FOR MIRROR LC4 '98	2
46	54802005100	CLAMP CPL. 06	1
63	54832063000	CLUTCH PIPE 06	1
69*	78111074000	STARTER BUTTON GREY 13	1
92*	78102091000	THROTTLE CABLE 4T. 13	1
94	58012040000	REAR MIRROR L/S	x
94	58012140000	REAR MIRROR R/S	x

137740210 / C137740213

\* NEW PART

X AS REQUIRED

# SIDE / CENTER STAND

250 EXC-F SIX DAYS EU 2013

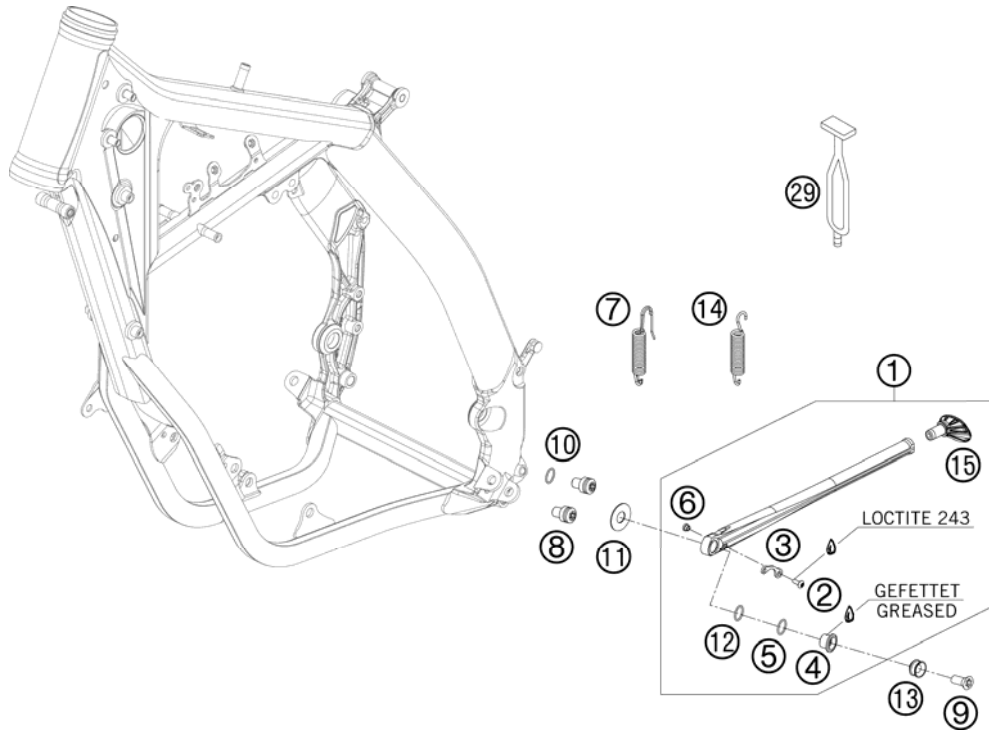

FIG	PART NUMBER	DESCRIPTION	QTY
1	78003023044	SIDE STAND CPL. 08	1
2	58605083014	SCREW M5X14 TORX 25 07	1
3	78003023090	SPRING BRACKET F. SIDE ST. 08	1
4	78003023080	SIDE STAND BUSHING EXC USA 08	1
5	0770180020	O-RING 18,00X2,00 NBR 70	1
6	78003023070	SPACER BUSH. SPRING BRACKET	1
7	81203024000	SIDE STAND SPRING EYE MOVEABLE ONLY FOR EXC	1
8	78003023182	SIDE STAND STOP SCREW M10X12	2
9	0019080206S	FLAT HEAD SCREW M. ISA45 M8X20	1
9	0019080266S	COUNTER-SUNK SCREW ISA45 M8X26 ONLY FOR 78003023081	1
10	0770120020	O-RING 12,00X2,00 NBR 70	1
11	78003023083	WASHER F. SIDE STAND 12,2X29,5	1
12	0770125015	O-RING 12,5X1,5 NBR	1
13	78003023081	SIDE STAND BUSHING EXC-EU 08	1
14	78003024100	SIDE STAND SPRING 08 ONLY FOR XC	1
15	78003023055	% STAND BASE	1
29	50303018000	RUBBER L=145MM	1

085230360 / C117800360

\* NEW PART

X AS REQUIRED

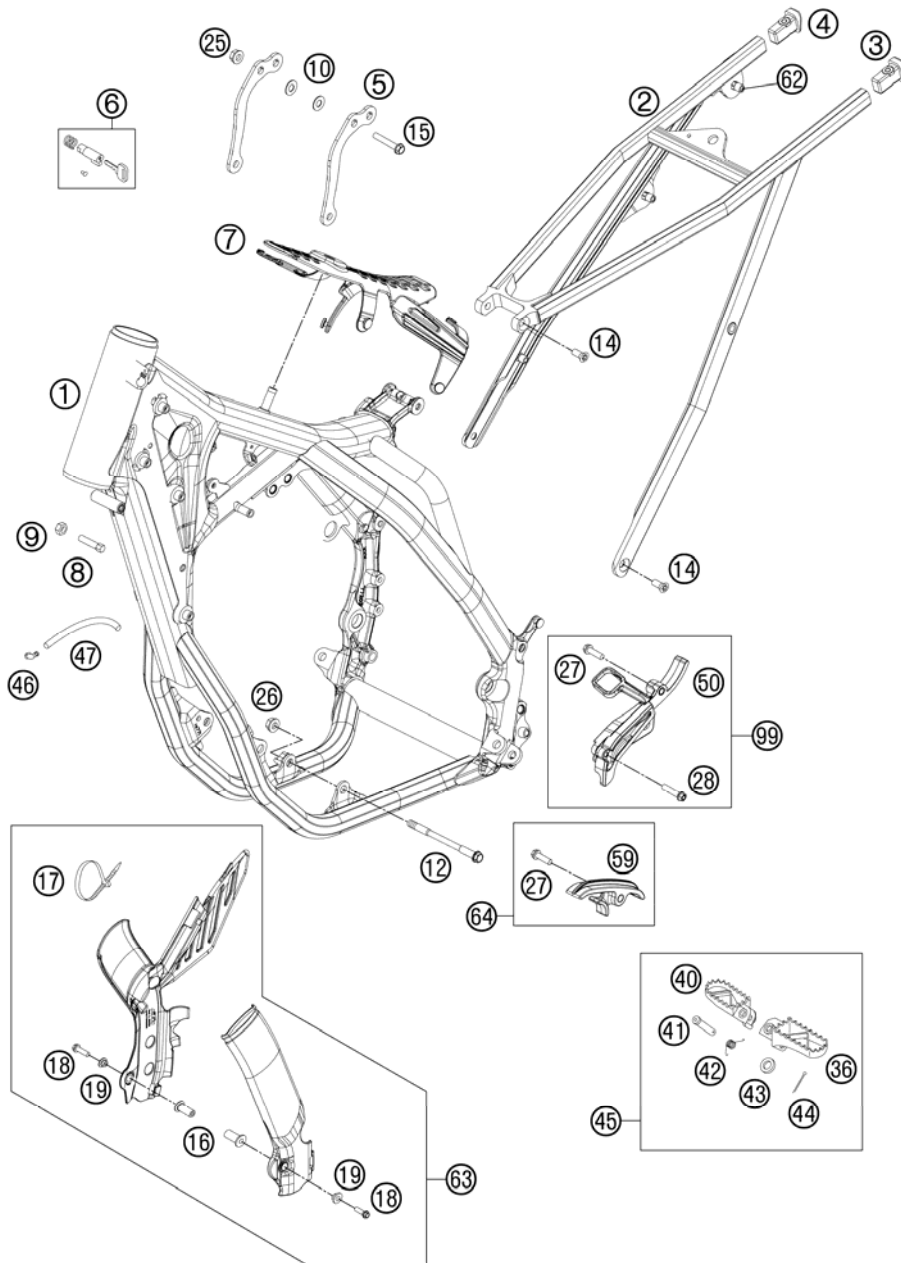

FIG	PART NUMBER	DESCRIPTION	QTY
1	7740300110004	FRAME ORANGE "774L1"	1
2	77203002000	SUB FRAME SX	1
3	78003002010	SUB FRAME APPLICATION LEFT 08	1
4	78003002020	SUB FRAME APPLICATION RIGHT 08	1
5	77403013000	REINFORC.BRACKET 250 EXC-F 12	2
6	78003035000	STEERING HEAD LOCK 08	1
7	77207012000	TANK REST RUBBER	2
8	59001037000	SPECIAL SCREW M8X26 WS=10	2
9	0934080003	HEXAGON NUT DIN0934-M 8	2
10	77003013050	WASHER 8,5X18X1 INOX	6
12	54603013000	ENGINE BRAC.SCR. M10X105 WS=13	2
14	0019080206S	FLAT HEAD SCREW M. ISA45 M8X20	4
15	56530079000	HH COLLAR SCREW M 8X44 WS13	3
16	54803092050	BLIND PLUG-IN NUT M5 WN 22A 03	2
17	44011076305	CABLE TIE 300/4,8MM BLACK	3
18	0738050250	COU.SUNK SCR. AH ISO7380 M5X25	2
19	54803092060	BUSH F. FRAME PROTECTION 03	2
25	54310086200	SELF LOCKING NUT M8 10.9	3
26	54310086100	SELF LOCKING NUT M10 CU WS=14	2
27	0025080306	HH COLLAR SCREW M8X30 TX40	2
28	0025060406	HH COLLAR SCREW M6X40 TX30	1
36	78003040050	FOOTREST L/S 08	1
40	78003041050	FOOTREST R/S 08	1
41	54803044000	BOLT FOR FOOT PED 03	2
42	54603041000	FOOTREST SPRING L/S & R/S	2
43	0125100003	WASHER DIN0125-A10,5	2
44	0094032253	PIN DIN0094-3,2X25 STEEL	2
45	78003040033	FOOTREST L/S + R/S CPL. 09	1
46	50303089000	ANGLE PIECE '97	1
47	55007016001	PVC-HOSE 7X10 PER METER	x
50	77003096000	SPROCKET COVER 250 SX-F 07	1
59	77203053000	CHAIN SLIDING PIECE BELOW	1
62	77303139000	BLIND RIVET NUT EM6-60LF/HX	4
63	77203094000	PLASTIC FRAME PROTECTION SET	1
64	77203053010	CHAIN SLIDING KIT BELOW CPL.11	1

127700310 / C137740311

\* NEW PART

X AS REQUIRED

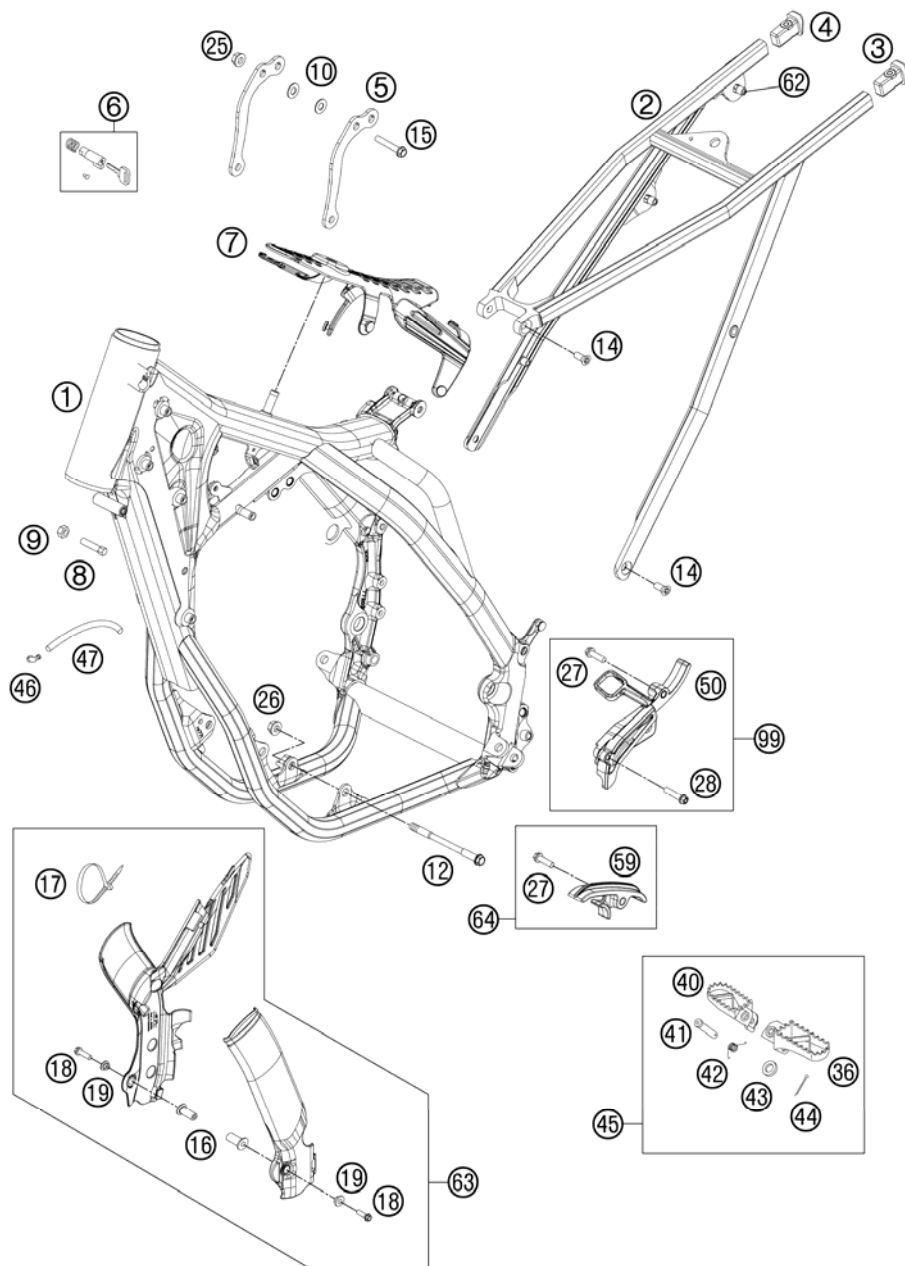

FIG	PART NUMBER	DESCRIPTION	QTY
99	77003096010	SPROCKET COVER KIT	x

127700310 / C137740311

\* NEW PART

X AS REQUIRED

# SHOCK ABSORBER

250 EXC-F SIX DAYS EU 2013

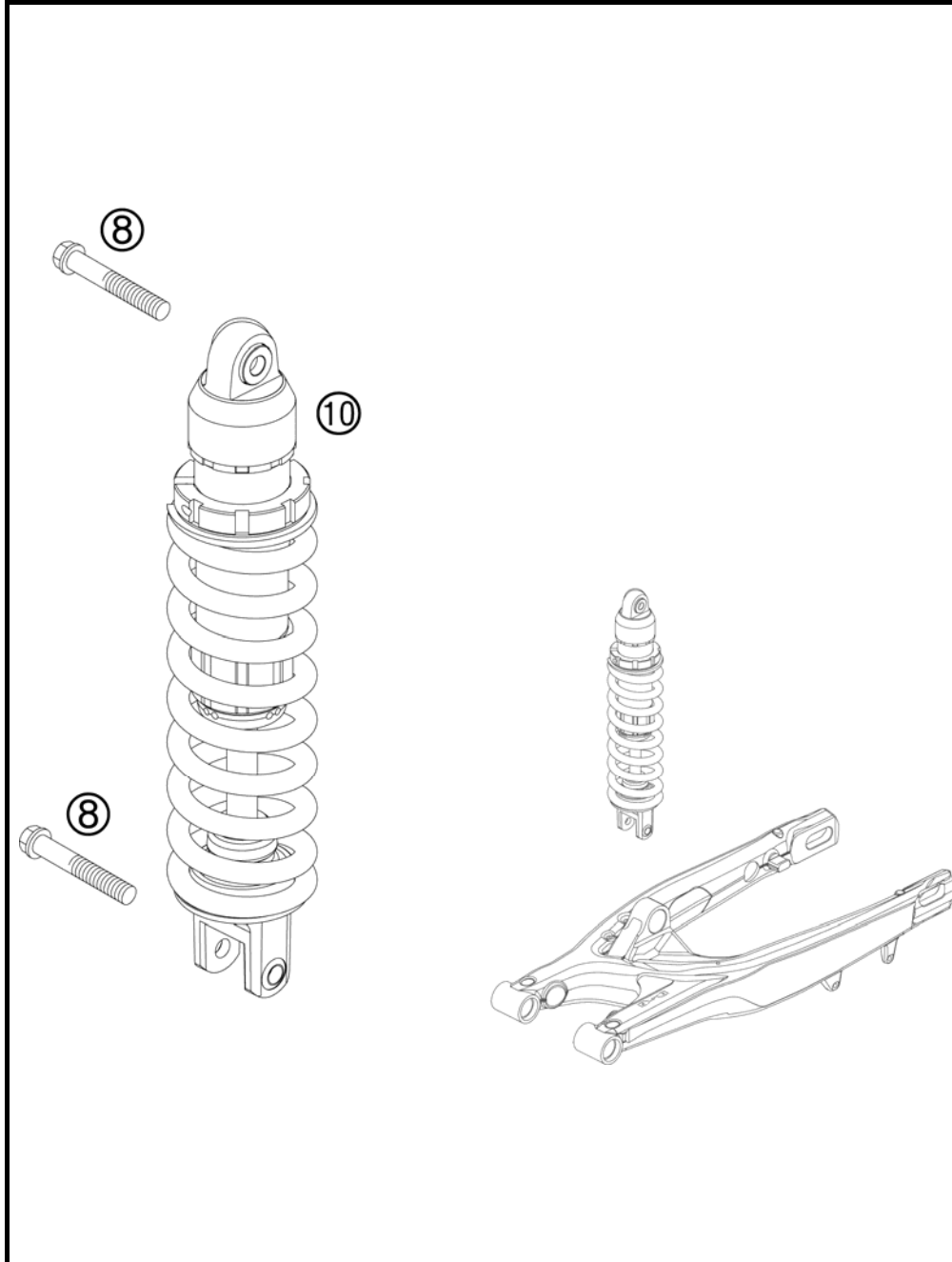

FIG	PART NUMBER	DESCRIPTION	QTY
8	0025120506S	HH COLLAR SCREW M12X50 TX45	2
10	12187L6301	MONOSHOCK 5018 PDS 250/300EXC	1

085030410 / C127740410

\* NEW PART

X AS REQUIRED

# SHOCK ABSORBER DISASSEMBLED

250 EXC-F SIX DAYS EU 2013

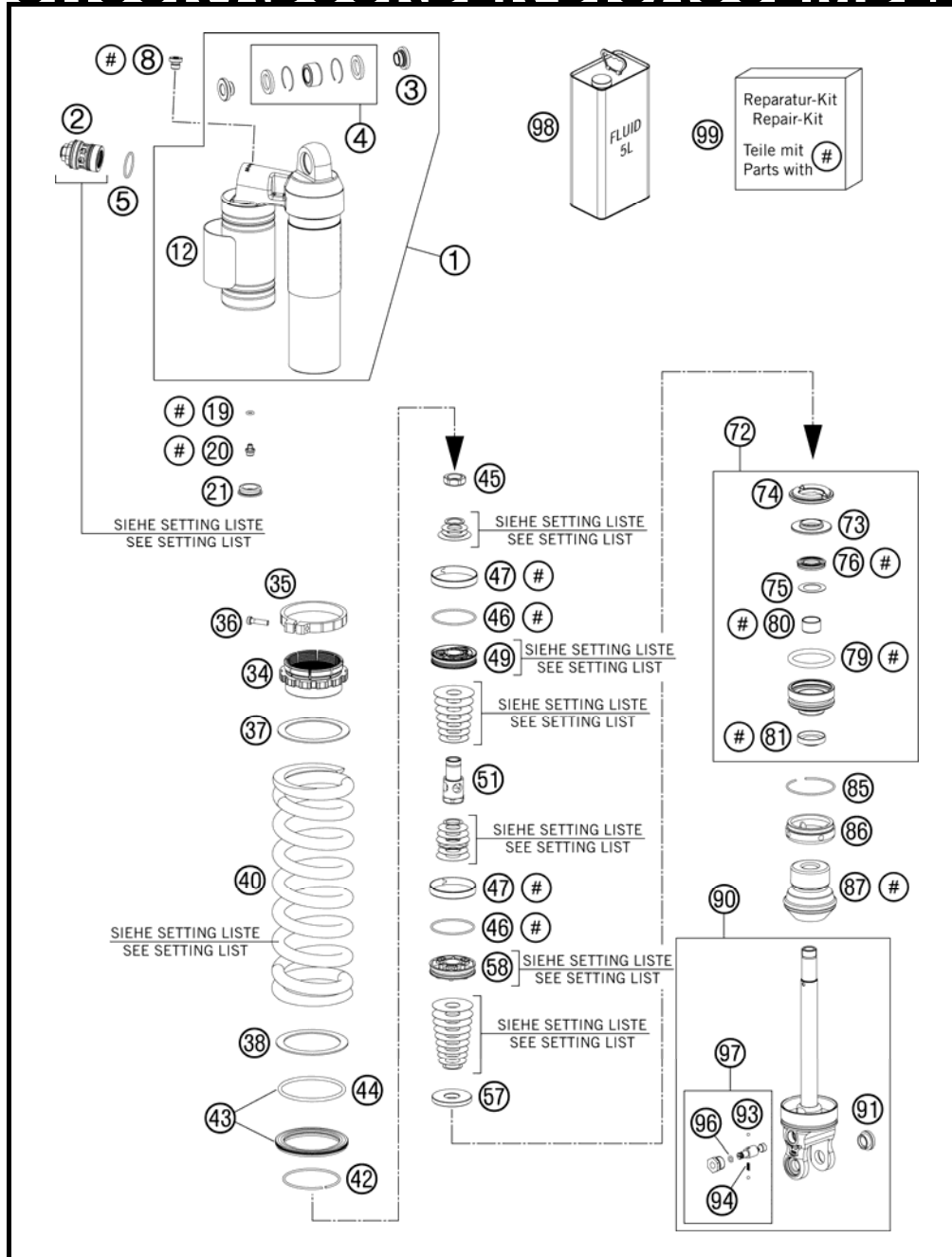

FIG	PART NUMBER	DESCRIPTION	QTY
1	50180833SA2	MONOSHOCK UPPER PART CPL.	1
2	50180213S10	DCC-COMPR.DAMP.CONTROL CPL. 07	1
3	46180007	ADAPTOR BUSH KGW 12X24	2
4	R12012	REP. KIT BEAR./SEAL UP. 07	1
5	50180217	O-RING 27X1,5 VITON	1
8	50180095	BLEED PLUG R 1/8	1
12	52000085	WP CAUTION (PDS KTM)	1
19	46810893	O-RING NBR 5,28X1,78	1
20	36120151	SCREW PLUG M5X6	1
21	46811208	RUBBER CAP "DO NOT OPEN"	1
34	50180938	ADJUSTING NUT PLASTIC	1
35	50180937	TENSIONING RING D64 H10	1
36	14460042	%ALLENHEAD SCREW M5 L=20 STAIN	1
37	50180965	SPACER RING SPRING 61,3X78X3	1
38	50180114	SPACER RING FOR SPRING	1
40	91210053S	SPRING 250 63N/MM ORANGE	x
40	91210054S	SPRING 250 66N/MM ORANGE	x
40	91210068S	SPRING 250 69N/MM ORANGE	x
40	91210069S	SPRING 250 72N/MM ORANGE	x
40	91210070S	SPRING 250 76N/MM	x
42	50180273	CIRCLIP 58,2X2	1
43	50180463S	SPRING RET. D=80 W. O-RING 05	1
44	50180352	O-RING VITON 66,27X3,53	1
45	50180627	PISTON ROD NUT M20X1	1
46	50180099	O-RING VITON 44,17X1,78	2
47	50180135	PISTON RING 50-8	2
49	50180675	PISTON D=20	1
51	50180973	SUPPORT D20 M20X1 L51,3 PDS	1
57	50180970	REBOUND DISC D43	1
58	50180197	PISTON 6+6X7/4,5	1
72	50180603S	ADAPTOR CPL. D=50 H=28 08	1
73	50180113	STEEL DISC 18X,5X43,7X6	1
74	50180107	REBOUND RUBBER	1
75	50180604	SHIM D29,75 X D19 X T0,4 08	1
76	50180605S	SEAL D18X30X5 08	1

125480430 / C127740430

\* NEW PART

X AS REQUIRED

# SHOCK ABSORBER DISASSEMBLED

250 EXC-F SIX DAYS EU 2013

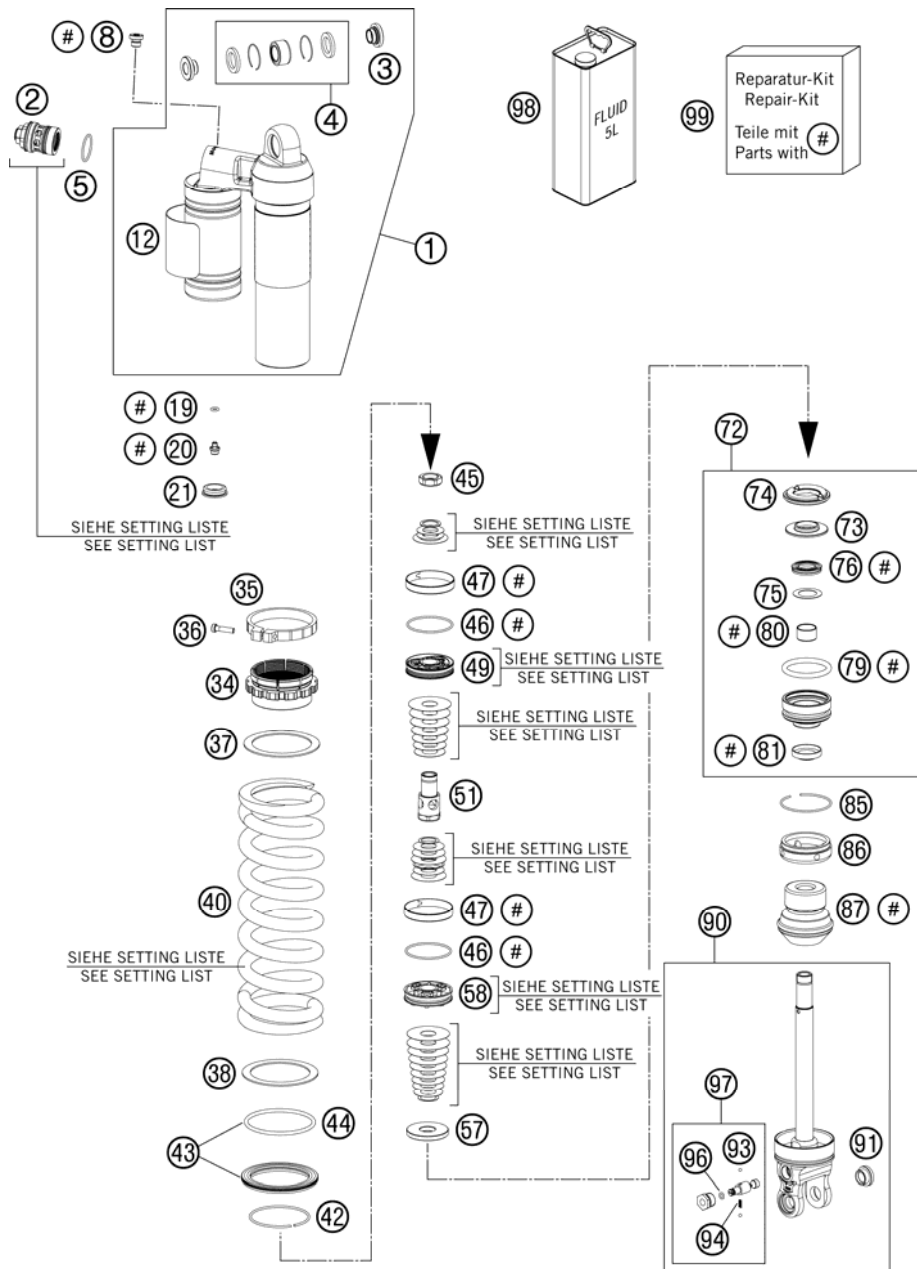

FIG	PART NUMBER	DESCRIPTION	QTY
79	50180103	O-RING 41X5	1
80	46180119	DU-BUSH 18X20X12	1
81	50180606	DUST SEAL 1828 08	1
85	50180126	CIRCLIP 53X1,75	1
86	50180626	RESERVOIR CAP D=50 H=10 09	1
87	50180600	BUMP RUBBER D58 D17 H59 2008	1
90	50180512SA4	SHOCK ABS. LOWER PART CPL. 12	1
91	50180105	THREADED BUSH M12 PDS	1
93	40540603	STEEL BALL D=3MM	2
94	48600028	SPRING D=2,9 L=7,9	1
96	50180222	O-RING NBR 4X1,5	1
97	50180434S	ADJUSTING SCREW REBOUND TRAVEL	1
98	50180751S1	SHOCK ABSORBER FLUID 5 LT	1
99	R12015	REPAIR KIT 5018 PDS 08	1

125480430 / C127740430

\* NEW PART

X AS REQUIRED



# SWING ARM

250 EXC-F SIX DAYS EU 2013

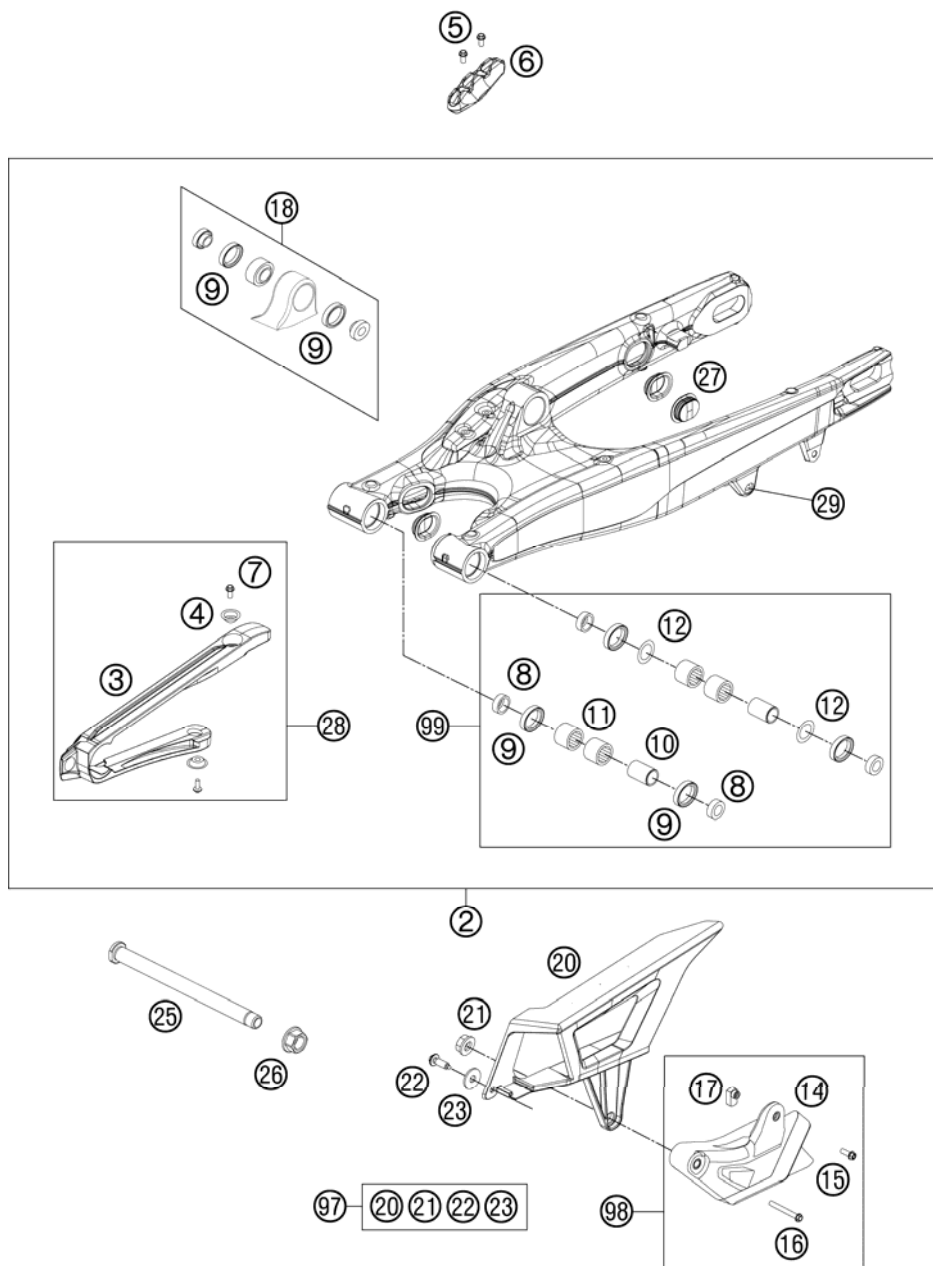

FIG	PART NUMBER	DESCRIPTION	QTY
2	51504030044	SWING ARM CPL. PDS 2011	1
3	51504066000	CHAIN SLID.GUARD PDS	1
4	77304066050	BUSHING F. CHAIN SLIDING PR.07	2
5	0009050106	EJOT SPIRAL SCREW SF M5X10-K	2
6	77313047000	BRAKE HOSE GUIDE LOWER 07	1
7	59009062013	SPECIAL SCREW M6X13 WS=8 10.9	2
8	54804034000	BUCKET F. SHAFT SEAL RING 03	4
9	0760253270	SHAFT SEAL RING 25X32X7	6
10	54804032000	BUSHING SLEEVE F. SWING ARM 03	2
11	58033097000	NEEDLE BEARING HK 2216	4
12	54603036000	STOP DISK 22,2X31,7X1	2
14*	7800407010004	CHAIN GUIDE CPL.	1
15	59009062019	SPECIAL SCREW M6X19 WS=8 10.9	1
16	0025060506	HH COLLAR SCREW M6X50 TX30	1
17	77304070030	INSERTION NUT F. CHAIN GUIDE	1
18	50304090144	PIVOT BEARING+BUSH. PDS '11	1
20	78104060000	CHAINGUARD	1
21	56509064100	SELF LOCKING NUT M6 10.9	1
22	0017060203	EJOT PT SCREW K60X20 WS=6	1
23	0021060003	WASHER DIN9021-A 6,4	1
25	77304037000	SWINGARM BOLT M16X1,5 07	1
26	54804038000	SELF LOCK.NUT M16X1,5 WS=19 03	1
27	77204041000	CLOSING COVER	4
28	51504066044	CHAIN SLIDING GUARD KIT 11-12	x
29	54603055051	PRESS IN NUT M6 STEEL ZINC	1
97	78104060010	CHAIN PROTECTION KIT EXC 12	x
98	7730407031004	CHAIN GUIDE KIT REAR ORANGE	x
99	54804230210	SWINGARM REPAIR KIT 05-12	x

135030491 / C135030491

\* NEW PART

X AS REQUIRED

# EXHAUST SYSTEM

250 EXC-F SIX DAYS EU 2013

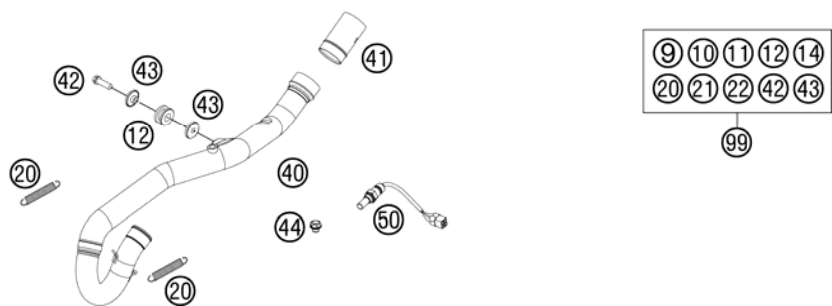
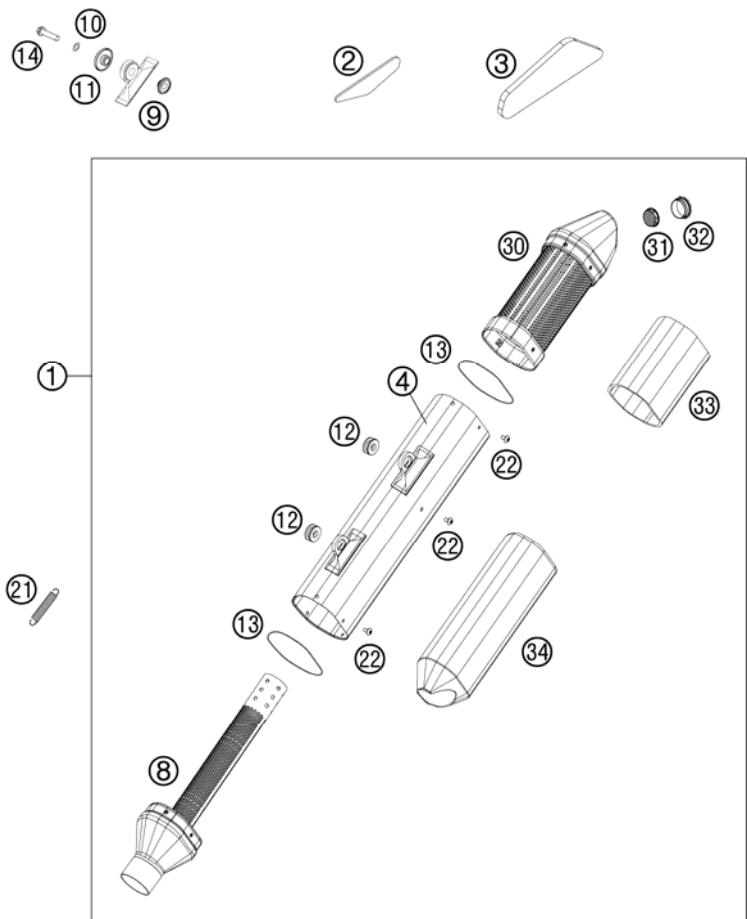

FIG	PART NUMBER	DESCRIPTION	QTY
1	7810508100059	SILENCER EXC SD	1
2	77308013050	THERMAL PROTECTION FOIL 07	1
3	77208013050	THERMAL PROTECTION FOIL	1
4	78105081080	SILENCER HOUSING EXC	1
8	78105081050	CONNECTING CAP	1
9	77205169000	BUSHING 7.5x12x28x8.3	2
10	0137060003	SPRING WASHER DIN0137-B 6	2
11	77205069000	BUSHING 7.5x12x20x8.2	2
12	77205068000	DAMP. COMPON. BLACK	3
13	0770740015	O-RING 74,00X1,50 FKM 75SH	2
14	0025060306	HH COLLAR SCREW M6X30 TX30	2
20	50305016000	TEN.SPRING L=62MM EY.MOVEABLE	2
21	50305116000	TEN.SPRING L=75MM EY.MOVEABLE	1
22	78105081010	SCREW TORX M5X10	12
30	78105081070	SILENCER CAP WITH INSERT	1
31	77005081065	THROTTLE ELEMENT CPL. EXC 07	1
32	77005081055	SIL. ELEMENT EXC-F 07	1
33	78105078070	STUFFING YARN REAR	1
34	78105078430	STUFFING YARN 430G	1
40	77405009000	EXHAUST PIPE EXC W. LAMBDA	1
41	78105091000	PLUG IN CAT 2012	1
42	0025080256	HH COLLAR SCREW M8X25 TX40	1
43	59405069000	BUSHING FOR EXHAUST SUPPORT 03	2
44	77405009065	PLUG SCREW M12X1,25 WS17	1
50	75041090000	LAMBDA SENSOR 07	1
99	00050000815	EXHAUST PARTS KIT 12-13	x

127700510 / C137740512

\* NEW PART

X AS REQUIRED

# AIR FILTER

250 EXC-F SIX DAYS EU 2013

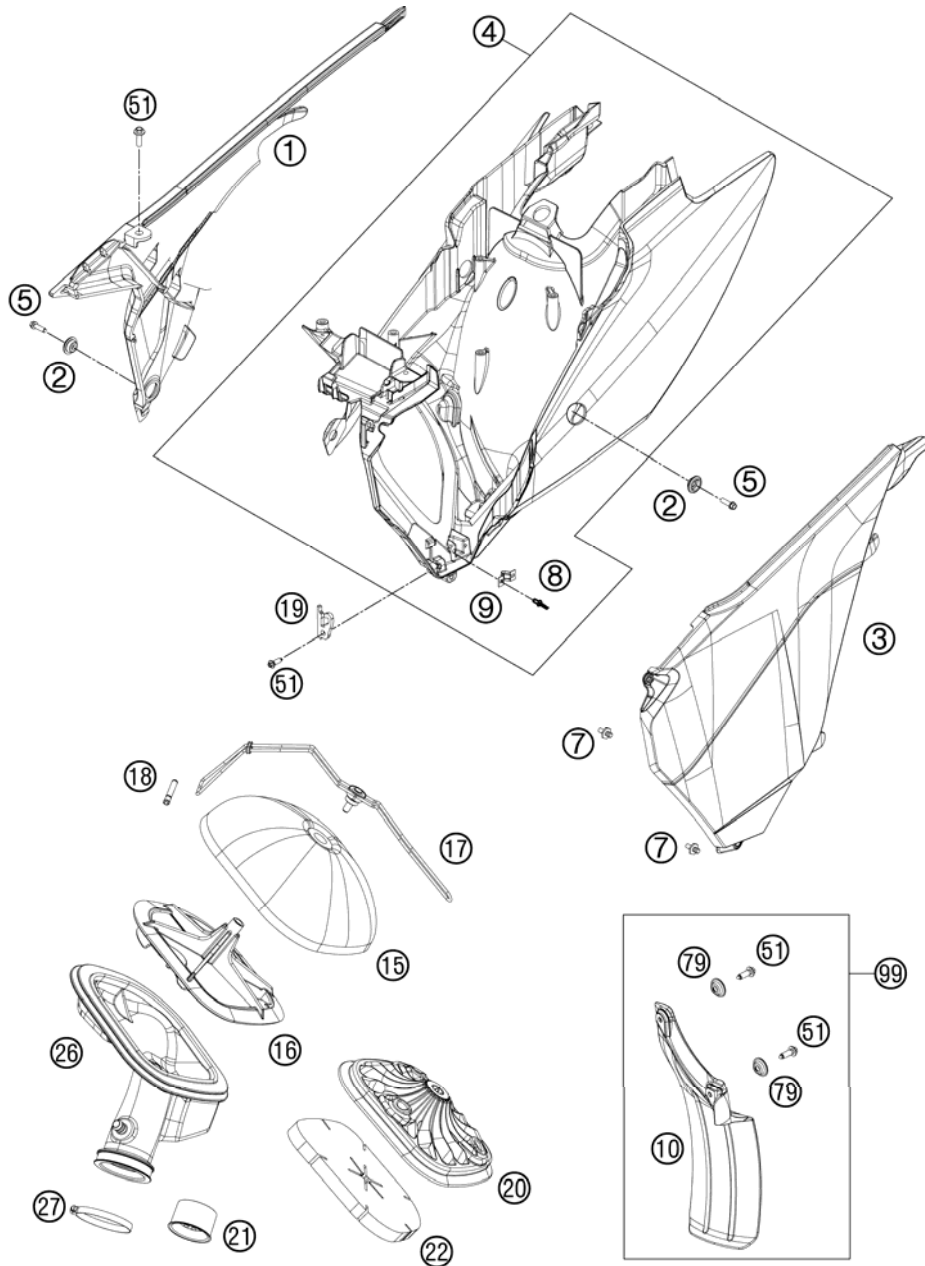

FIG	PART NUMBER	DESCRIPTION	QTY
1	7720600410028	AIR BOX COVER OR. RIGHT PDS	x
1*	7720600410028B	AIRFILTERBOX COVER R/S SD 13 WITH DECAL	x
2	77308013010	COLLAR BUSH. F.REAR FENDER 07	2
3	7720600300028	AIR FILTER BOX COVER L/S	x
3*	7720600300028B	AIRFILTERBOX COVER L/S SD 13 WITH DECAL	x
4	7720600104428	% FILTER BOX CPL. WHITE 12	1
5	0025060206	HH COLLAR SCREW M6X20 TX30	2
7	54806008051	QUICK RELEASE-NIPPLE 03	2
8	54806108052	BLIND RIVET 3,3X9,7 GROOVED 04	4
9	54806008050	QUICK RELEASE-SPRING HANGER	2
10	77306010000	FENDER FOR FILTER BOX	1
15	77206015000	AIR FILTER	1
16	77206016000	FILTER CARRIER 11	1
17	77206017000	FILTER SUPPORT CPL. 11	1
18	77306018000	FILTER SUPPORT BUSH 07	1
19	77206019000	FASTEN. DEVICE FILTER S. SX 11	1
20	78106012000	TROTTLE VALVE	1
21	78106012050	THROTTLE	1
22	78106014000	RESTRICTOR CAP FILTER	1
26	77406026000	AIRBOXRUBBER 250 EFI	1
27	78006027000	HOSE CLAMP 45-65MM	1
51	0017060204	EJOT PT SCREW K60X20 ALU WS=6	4
79	77304066050	BUSHING F. CHAIN SLIDING PR.07	2
99	77306010010	SPLASH PROTECTOR KIT SX/EXC	x

137740610 / C137740612

\* NEW PART

X AS REQUIRED

# TANK, SEAT, COVER

250 EXC-F SIX DAYS EU 2013

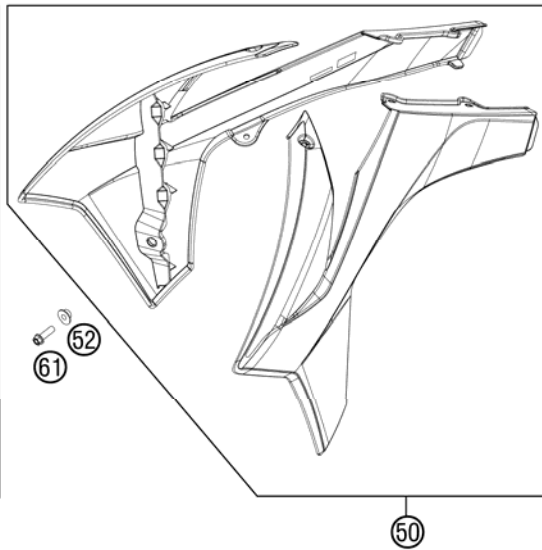
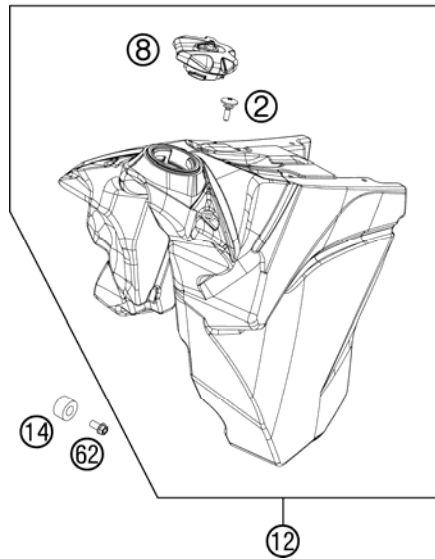
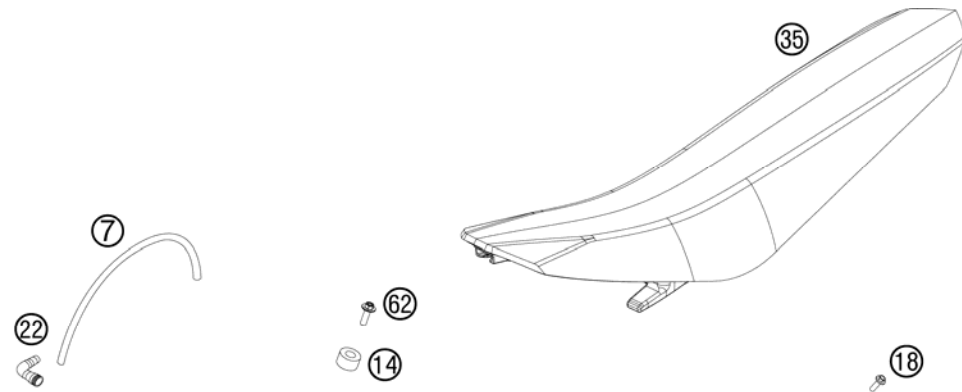

FIG	PART NUMBER	DESCRIPTION	QTY
2	50307011000	SCREW SEAT FASTENING D=6X23/18	1
7	78007000270	PVC-HOSE 5,6X10X270MM	1
8	78007008044X4	TANK PLUG ORANGE/BLACK	1
12	7740701304499	FUEL TANK CPL. 9,5L EFI EXC	1
14	50307014000	TANK ROLLER 12X26X12 '98	3
18	0017060204	EJOT PT SCREW K60X20 ALU WS=6	8
22	51030022000	ANGLE PIECE 90 DEGREE M10X1	1
35	77207040100	SEAT "CAMEL "	1
50	7720805400028	SPOILER KIT WHITE SX/XC 11	x
50*	7720805400028B	SPOILER KIT EXC SIX DAYS 2013 WITH DECAL	x
52	50308052000	BUSH FOR SPOILER 6X11X16X5 MM	2
61	0025060206	HH COLLAR SCREW M6X20 TX30	2
62*	0026060136	COLLAR SCREW M6X13 ISA30	3

127700711 / C137700710

\* NEW PART

X AS REQUIRED

# FUEL PUMP

250 EXC-F SIX DAYS EU 2013

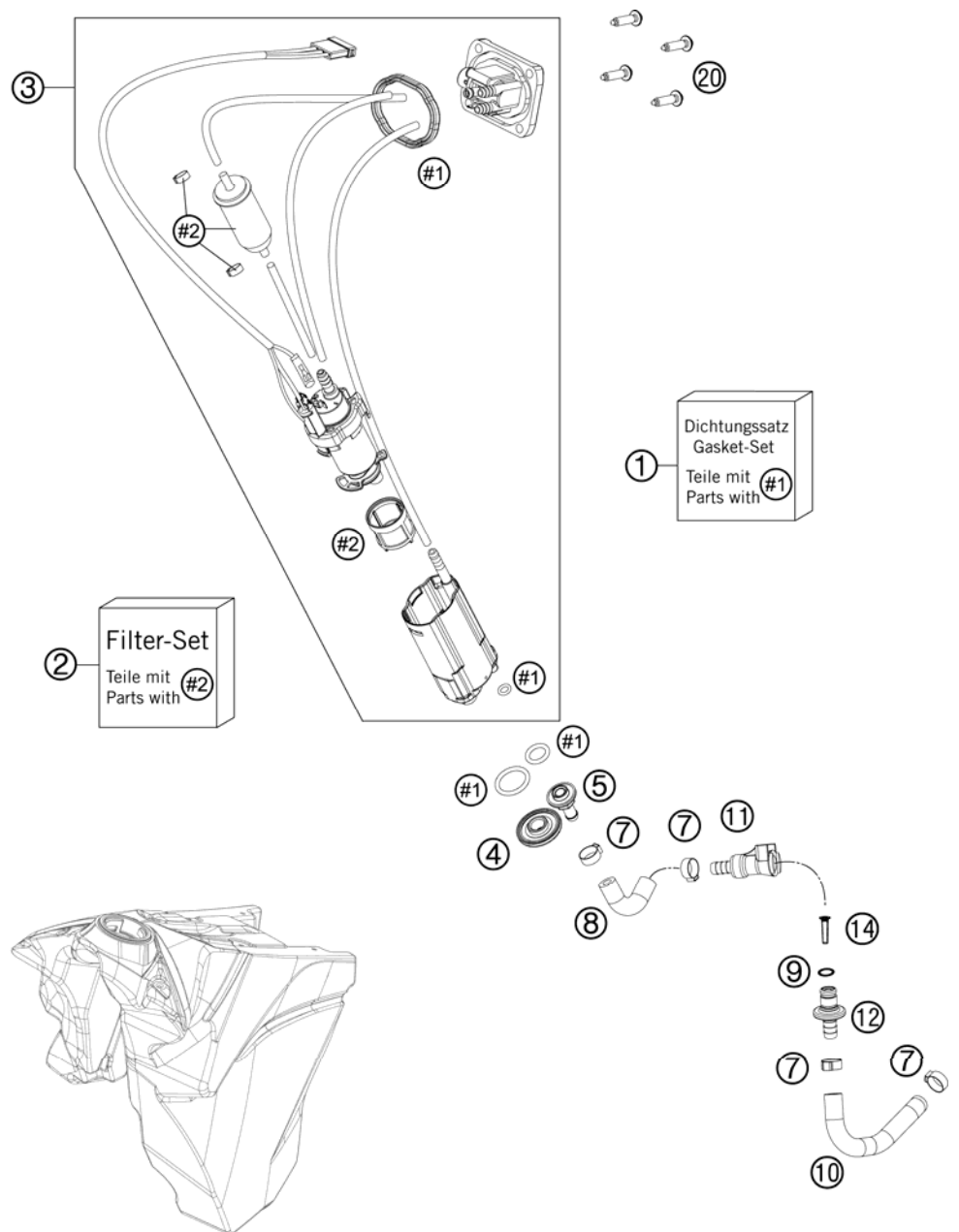

FIG	PART NUMBER	DESCRIPTION	QTY
1	78107089000	GASKET KIT	1
2	81207090000	FILTER KIT	1
3	78107088000	FUEL PUMP CPL. EXC	1
4	78107088014	NUT F. FUEL PUMP M12	1
5	78107088017	FUEL CONNECTOR M8	1
7	00050157706	VARIABLE ONE-EAR CLAMP 15,7MM	4
8*	77407116100	FUEL HOSE TANK	1
9	58507012000	O-RING VITON F. PLUG CPC 05	1
10*	77407016100	FUEL HOSE PREFORMED DKK	1
11	5850701050030	CLUTCH CPC BLACK 05	1
12*	77707010000	CONNECTOR FUEL PUMP	1
14*	78141013190	FUEL FILTER	1
20	0017060253	EJOT PT SCREW K60X25-Z SW=6	4

137740730 / C137740730

\* NEW PART

X AS REQUIRED

# MASK, FENDERS

250 EXC-F SIX DAYS EU 2013

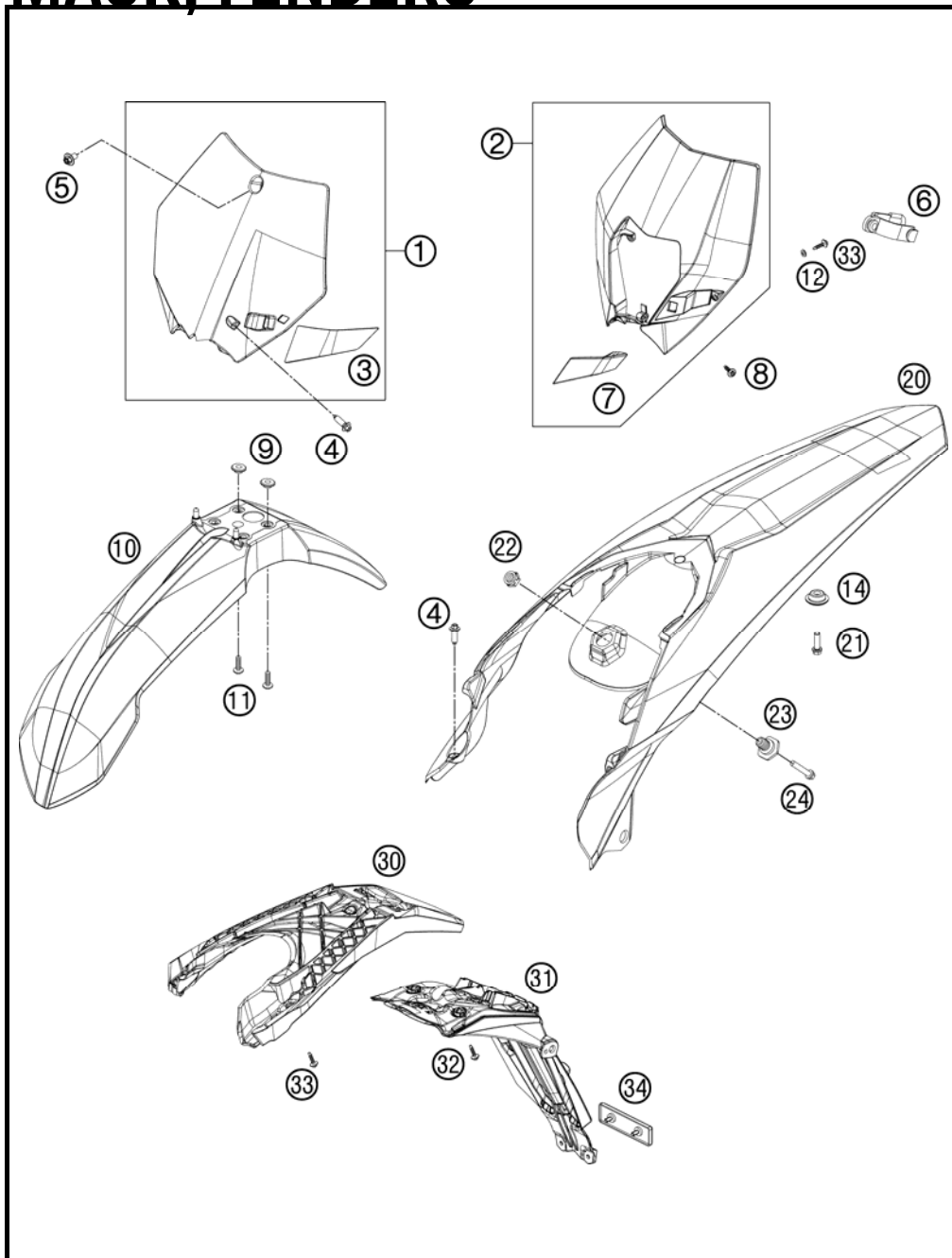

FIG	PART NUMBER	DESCRIPTION	QTY
1	7730800704428	START NUMBER PLATE CPL. WHITE	1
2	7800800100028	HEAD LIGHT MASK WHITE 2011	1
3	7730802200030	BRAKE HOSE GUIDE BLACK 08	1
4	0017060204	EJOT PT SCREW K60X20 ALU WS=6	2
5	0024060106	HH COLLAR SCREW M6X10 TX30	1
6	50211086000	MASK RUBBER UFO WP '95	2
7	7800802200028	BRAKE HOSE GUIDE WHITE	1
8	0081050181	SCREW FOR PLASTIC K50X18 T20	3
9	54808020000	SPACER BUSHING 03	4
10	7730801000028	FRONT FENDER WHITE	1
11	0024060206	HH COLLAR SCREW M6X20 TX30	4
12	0125060003	WASHER DIN0125-A 6,4	1
14	77308013010	COLLAR BUSH. F.REAR FENDER 07	2
20	7810801300028	REAR FENDER WHITE	1
21	0025050206	HH COLLAR SCREW M5X20 TX30	2
22	50314057050	COLLAR NUT M12X1/WS17 H=5MM	1
23	54807048000	BUSHING FOR SEAT FASTENING 03	1
24	0025060256	HH COLLAR SCREW M6X25 TX30	1
30	78108016000	NUMBER PLATE CARRIER TOP	1
31	78108016050	NUMB.PLATE CARRIER BOTTOM	1
32	0017060303	SPECIAL SCREW T60 6X30 WS=6	2
33	0017060203	EJOT PT SCREW K60X20 WS=6	3
34	58412080000	REFLECTOR RED LC4 '98	1

125030810 / C127750812

\* NEW PART

X AS REQUIRED

①

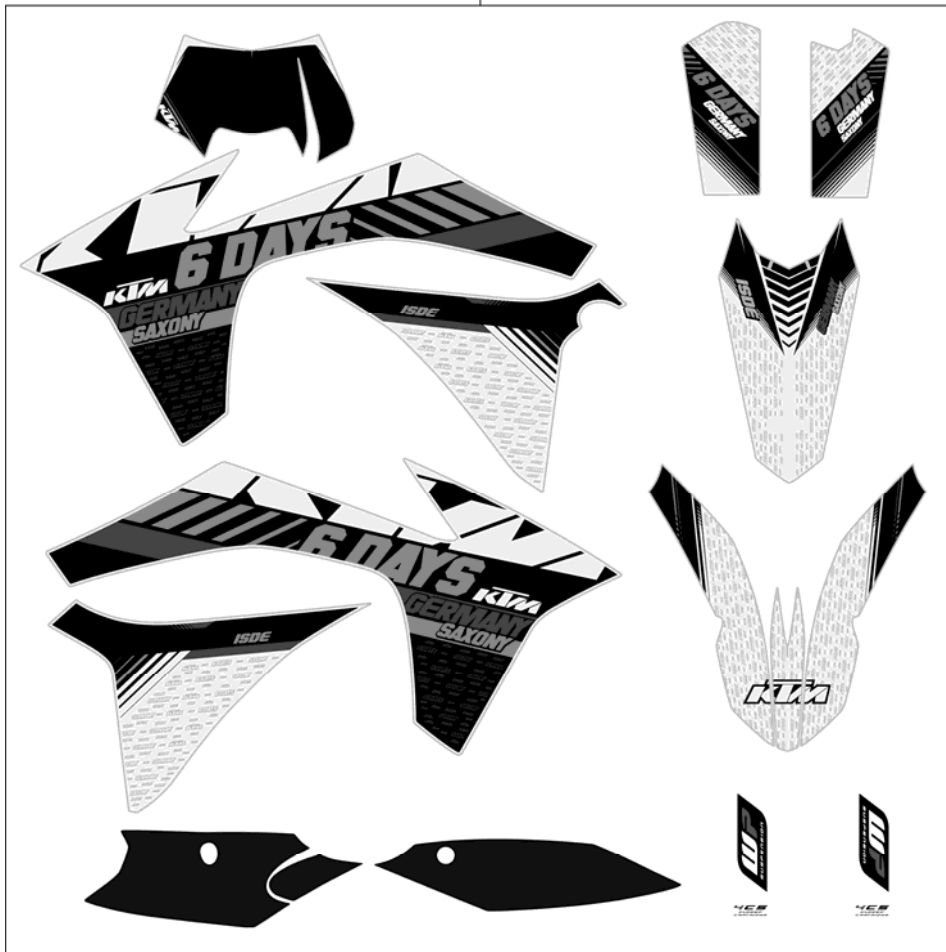

②

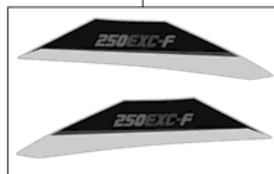

FIG	PART NUMBER	DESCRIPTION	QTY
1*	78708990000	GRAPHIC KIT SIX-DAYS GERMANY	1
2*	77408098400	DECAL REAR PART 250EXC-F SD 13	1

137740832 / C137740832

\* NEW PART

X AS REQUIRED

# FRONT WHEEL

250 EXC-F SIX DAYS EU 2013

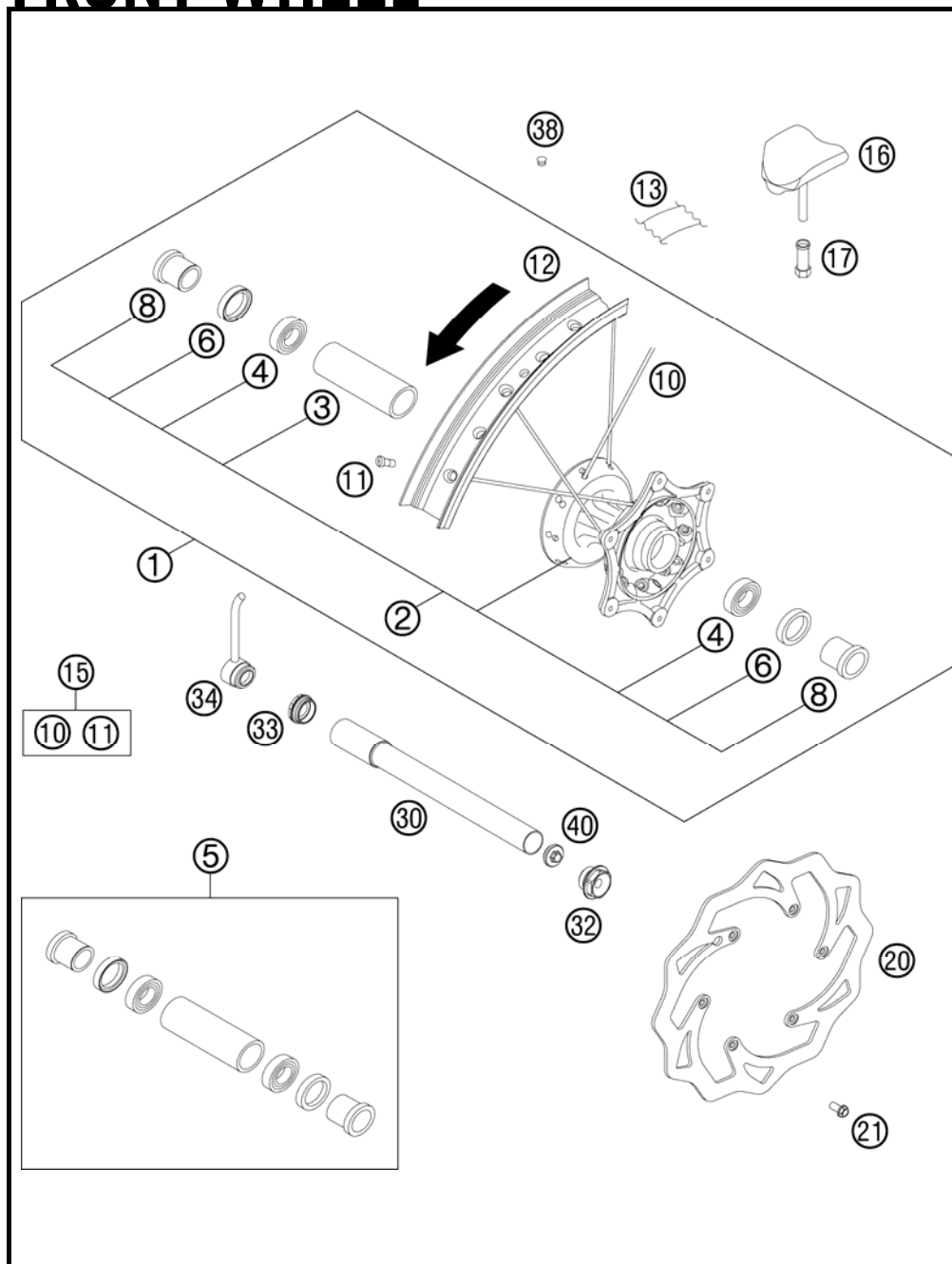

FIG	PART NUMBER	DESCRIPTION	QTY
1*	7810900114430	FR. WHEEL CPL.1,6X21"BLK. SD13	1
2	78009010144	FRONT WHEEL HUB CPL.	1
3	54809011000	BEA.SPACERTUBE 35X2 L=79,4 03	1
4	0625069068	GR.BALL BEAR.6906 DDU2CG23S6NM	2
5	78009015000	FRONT WHEEL REP. KIT	1
6	0760354771	SHAFT SEAL RING 35X47X7 TC	2
8	78009012000	SPACER BUSHING F. FR. WHEEL 08	2
10	7710907122630	SPOKE M4,5X226- 21" BLACK 12	36
11	77109072000	SPOKE NIPPLE M4,5 AL 11	36
12*	7810907010030	RIM FRONT 1,6X21" BLACK	1
13	50309073000	RIM BAND 21"	1
15	00050000954	SPOKE KIT FRONT "21" BLACK	x
16*	78109090000	RIM LOCK 1,60"	1
17	77110090050	NUT FOR WHEEL HOLDER	1
20	77309060000	BRAKE DISC FRONT 260	1
21	59009062013	SPECIAL SCREW M6X13 WS=8 10.9	6
30	77309081000	WHEEL SPIN.FR. D=26 M24x1,5 07	1
32	54809082000	SPINDLE SCREW M24X1,5 WS=27 03	1
33	54809081050	PLUG BUSHING WS=27 03	1
34	54809081060	FRONT AXLE PULL 26MM 04	1
38	55003135000	PLUG FOR RIM	x
40	54809081070	AUXILIARY SCREW FRONT 06	1

125030910 / C135030911

\* NEW PART

X AS REQUIRED



# REAR WHEEL

250 EXC-F SIX DAYS EU 2013

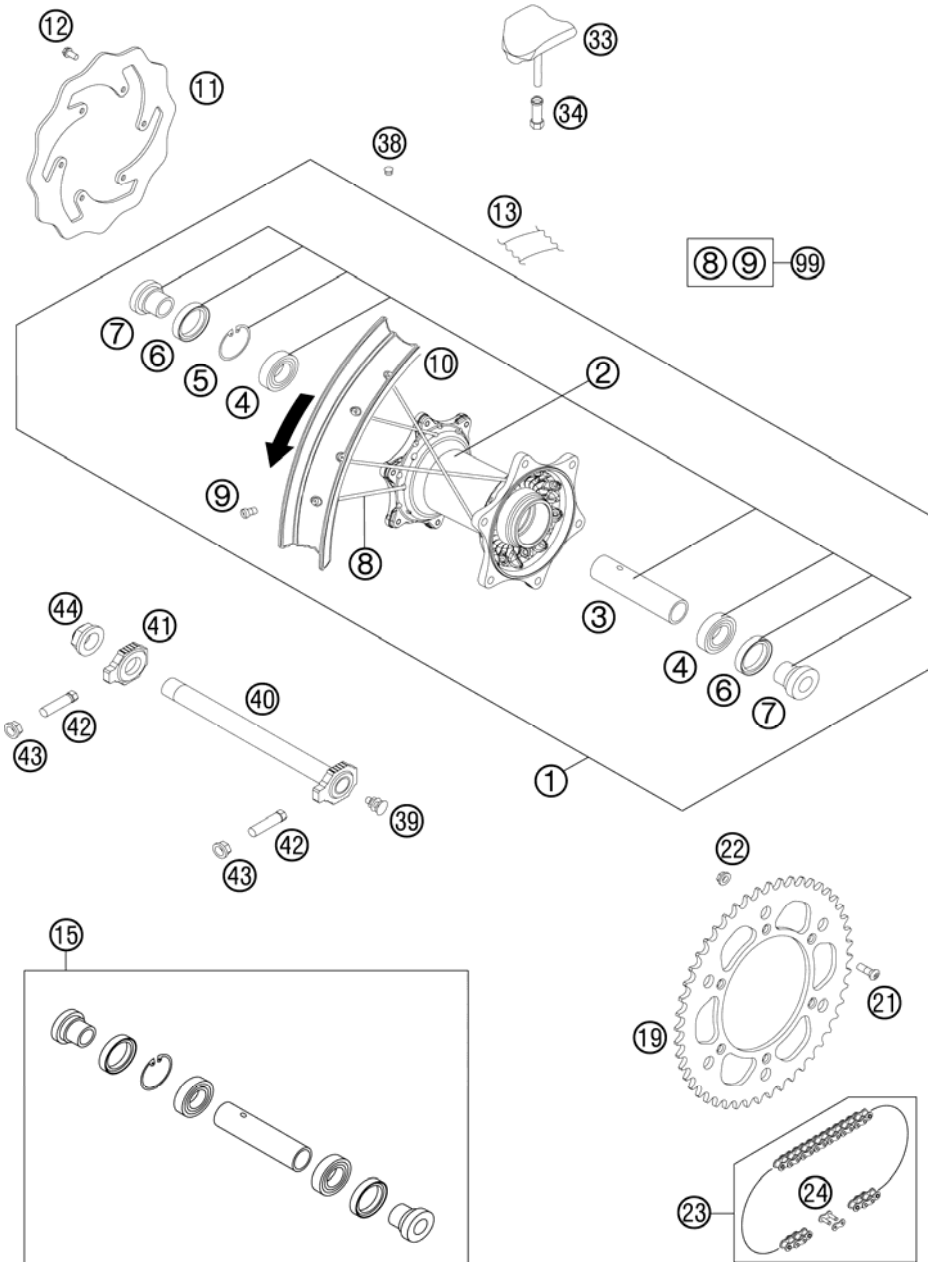

FIG	PART NUMBER	DESCRIPTION	QTY
1*	7811000114430	RE.WHEEL CPL.2,15X18"BLK.SD 13	1
2	78010010144	REAR WHEEL HUB CPL.	1
3	59010011000	BUSHING SPACER TUBE 121,5MM 01	1
4	0625060058	GR.BALL BEAR.6005 DDU2CG23S6NM	2
5	0472047175	CIRCLIP DIN0472-47X1,75	1
6	0760324771	SHAFT SEAL RING 32X47X7 BSL	2
7	78010016000	BUSHING FOR HUB 08	2
8	7711007119330	SPOKE M4,5X193- 18" BLACK 12	36
9	77109072000	SPOKE NIPPLE M4,5 AL 11	36
10*	7811007010030	RIM REAR 2,15X18" BLACK	1
11	78010960000	REAR BRAKE DISK	1
12	59009062013	SPECIAL SCREW M6X13 WS=8 10.9	6
13	50310073200	RIM BAND 18" AND 19"	1
15	78010015000	REAR WHEEL REP. KIT	x
19	5841005103804	REAR SPROCKET ORANGE 38-T	x
19	5841005104004	REAR SPROCKET ORANGE 40-T	x
19	5841005104204	REAR SPROCKET ORANGE 42-T	x
19	5841005104404	REAR SPROCKET ORANGE 44-T	x
19	5841005104804	REAR SPROCKET ORANGE 48-T	x
19	5841005104904	REAR SPROCKET ORANGE 49-T	x
19	5841005105004	REAR SPROCKET ORANGE 50-T	1
19	5841005105104	REAR SPROCKET ORANGE 51-T	x
19	5841005105204	REAR SPROCKET ORANGE 52-T	x
21	0019080266S	COUNTER-SUNK SCREW ISA45 M8X26	6
22	06923080003	HEXAGON NUT DIN EN1661 M8 SW13	6
23	78010167118	CHAIN DID 118 ROLLS	1
24	78010166000	CONNECTING LINK F. 78010167118	1
33	78110090000	RIM LOCK 2,15"	1
34	77110090050	NUT FOR WHEEL HOLDER	1
38	55003135000	PLUG FOR RIM	x
39	50210086000	COVERING CAP SFL16	x
40	77310085044	WHEEL SPINDLE RE. CPL.265MM 07	1
41	50310084000	CHAIN TENSIONER R/S 2000	1
42	50304040100	SCREW M10X1,25X50 WS=10	2
43	58414030000	HH COLLAR NUT M10X1,25 WS=13	2

135031013 / C135031013

\* NEW PART

X AS REQUIRED

# REAR WHEEL

250 EXC-F SIX DAYS EU 2013

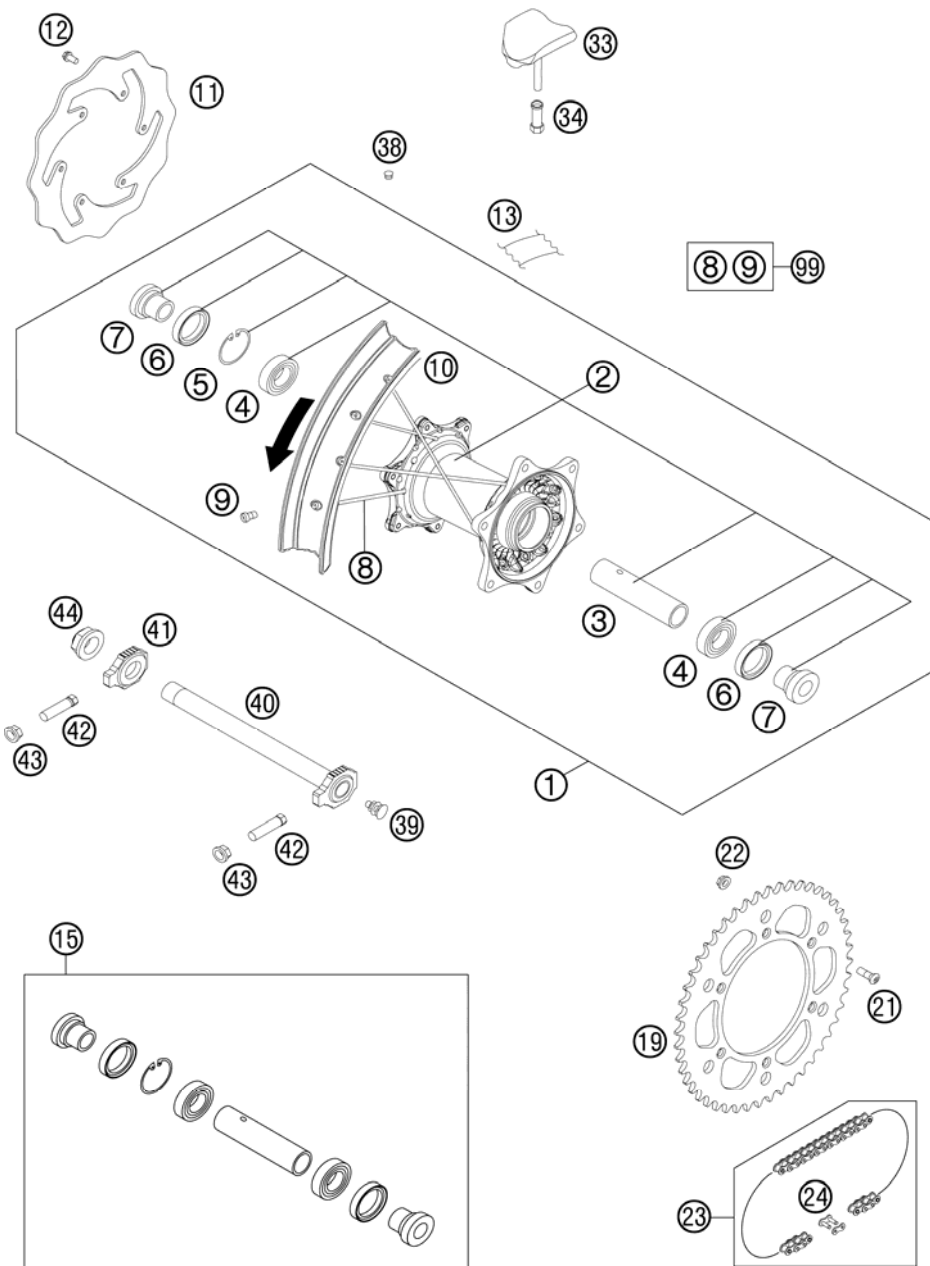

FIG	PART NUMBER	DESCRIPTION	QTY
44	50310099000	HEXAGON NUT M20X1,5 '98	1
99	00050000958	SPOKE KIT REAR 18" BLACK	x

135031013 / C135031013

\* NEW PART

X AS REQUIRED

# WIRING HARNESS

250 EXC-F SIX DAYS EU 2013

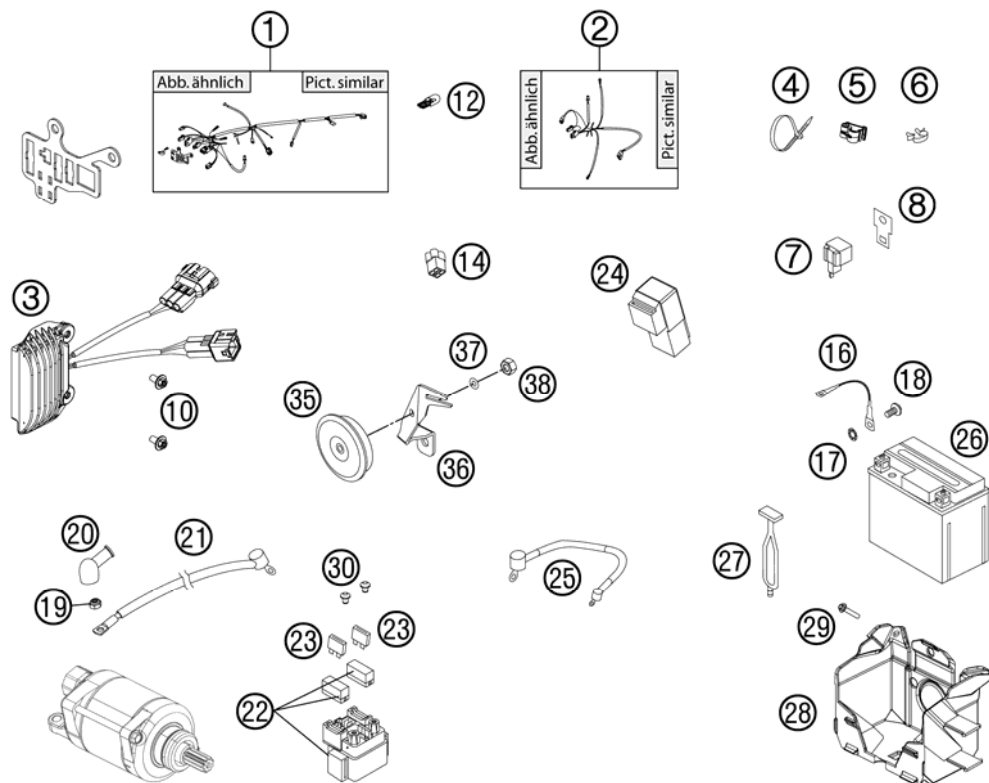

FIG	PART NUMBER	DESCRIPTION	QTY
1	78111075033	WIRING HARNESS EFI VMT. EU/AUS	1
2	78111079000	WIR.HARN.LIGHT EFI KPL. EU 12	1
3	78111034000	VOLTAGE REGULATOR	1
4	44011076140	CABLE TIE 140/2,5MM BLACK	x
4	44011076200	CABLE TIE 200/3,6MM BLACK	x
4	44011076305	CABLE TIE 300/4,8MM BLACK	x
5	83013026000	CABLE GUIDE	2
6	57013072100	WIRING HOLDER 16MM	1
7	44611207200	FLASHER UNIT 97	1
8	58211031100	BRACKET FOR FLASHER RELAY	1
10	0023060123	COLLAR SCREW M6X12 TX	2
12	49111425200	BULB 12V 2,3W (W2X4,6D)	3
14	81211096000	DUMMY PLUG AN 4-PIN	1
16	58411097100	GROUND CABLE D=6MM L=140MM '97	1
17	58411098100	CONTACT WASHER M6 VSV-K6	1
18	0009050106	EJOT SPIRAL SCREW SF M5X10-K	1
19	0985060003	SELF LOCK. NUT DIN0985-M 6	1
20	58440099000	PROTECTION CAP F. STARTER ENG.	1
21	58411059100	STARTERCABLE 700 MM '97	1
22	58211058000	STARTER RELAY 12V '99	1
23	58011109120	FUSE 20 A	2
24	61111057000	RELAY CM1A-R-12V-H80 07	2
25	58711086000	WIRING HARNESS BATTERY DUKE'99	1
26	77311053000	BATTERY 12V 3AH YTX4L-BS	1
27	50303018000	RUBBER L=145MM	1
28	77211055000	BATTERY BOX	1
29	0017060203	EJOT PT SCREW K60X20 WS=6	3
30	0902060083	AH OVAL SCREW ISO 7380 M 6X8	2
35	50311060200	DC HORN 12V 07	1
36	78011061000	HORN BRACKET EXC 08	1
37	0125050003	WASHER DIN0125-A 5,3	1
38	0934050003	HEXAGON NUT DIN0934-M 5	1

127751110 / C137741110

\* NEW PART

X AS REQUIRED

# BRAKE CALIPER REAR

250 EXC-F SIX DAYS EU 2013

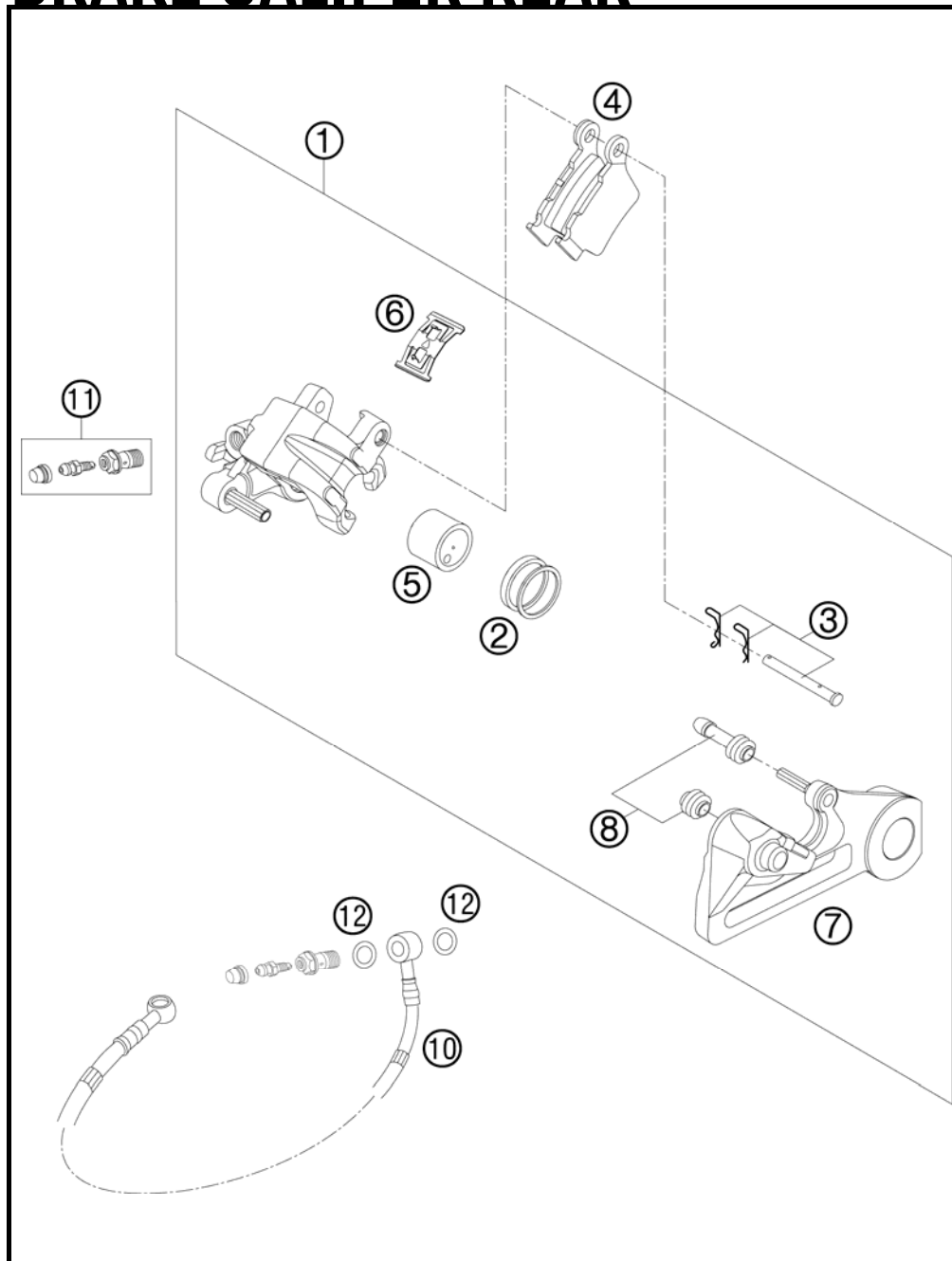

FIG	PART NUMBER	DESCRIPTION	QTY
1	54813080101	BRAKE CAL. RE. - WITHOUT PADS	1
2	50313081200	REPAIR KIT SEALING RINGS 26MM	1
3	54813082000	BOLT SET FOR BRAKE CALIPER 03	1
4	54813090300	BRAKE PAD SET REAR TOYO	1
5	54813083000	BRAKE PISTON 26MM 2003	1
6	54813018000	RETAINING SPRING SET 2003	1
7	54813075000	BRAKE CALIPER SUPPORT REAR	1
8	54613218000	CUP SET SHORT	1
10	54813070000	BRAKE HOSE REAR 655MM 03	1
11	62513020000	BLEEDER SCREW CPL. 05	1
12	0603100141	COPPER GASKET DIN7603-10X14X1	2

095031390 / C105031390

\* NEW PART

X AS REQUIRED

# HAND BREAK CYLINDER

250 EXC-F SIX DAYS EU 2013

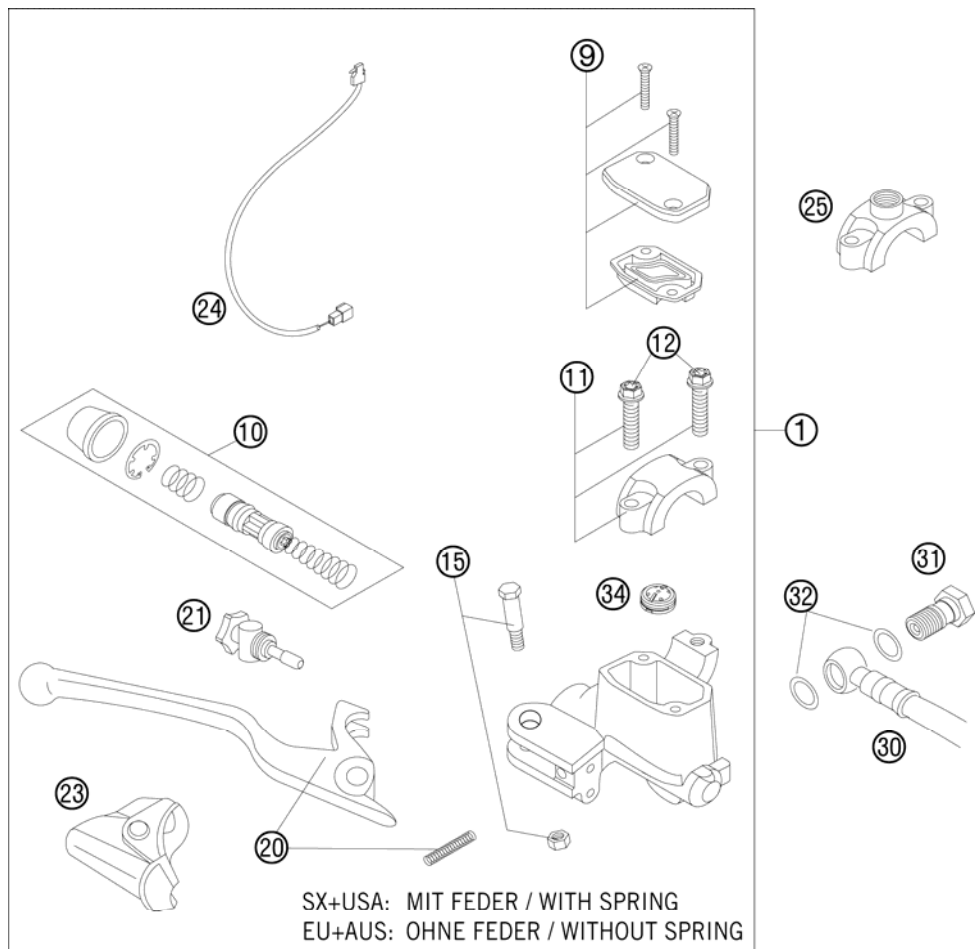
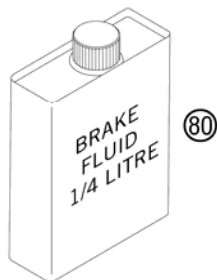

FIG	PART NUMBER	DESCRIPTION	QTY
1	77013001144	HAND BRAKE CYLINDER CPL.EXC 09	1
9	50313003000	HANDBRAKE CYL.COVER CPL.NATURE	1
10	54813008300	REP.SET PISTON D=9MM 2009	1
11	50313005000	CLAMP CPL. NATURE	1
12	0025060256	HH COLLAR SCREW M6X25 TX30	2
15	50313006100	LEVER SCREW CPL. 2001	1
20	54813002200	HAND BRAKE LEVER + SPRING 2009	1
21	54813007300	ADJUSTING SCREW CPL. SX 2009	1
23	50313004000	PROTECTION CAP HAND BRAKE CYL.	1
24	50311050100	BRAKE LIGHT SWITCH FRONT 2002	1
25	58012040150	CLAMP FOR MIRROR '94	1
30	59013011000	BRAKEHO. FRONT 1300MM 2000	1
31	54813020100	HOLLOW SCREW BLACK M10X1X19	1
32	0603100141	COPPER GASKET DIN7603-10X14X1	2
34	54802051000	VALVE	1
80	00062030000	BRAKE FLUID DOT5.1 0,25L	1



095511310 / C117801311

\* NEW PART

X AS REQUIRED

# BREAK CALIPER FRONT

250 EXC-F SIX DAYS EU 2013

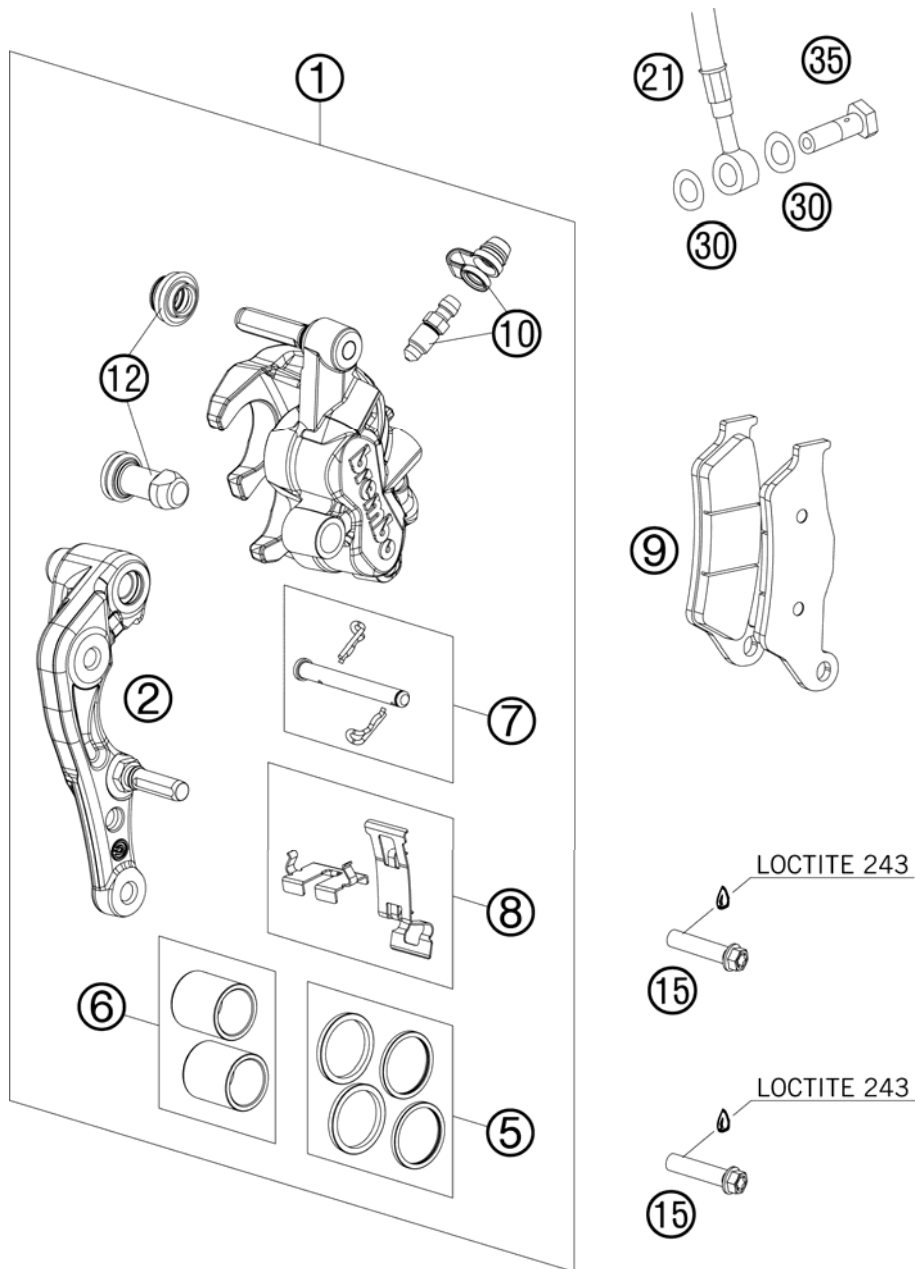

FIG	PART NUMBER	DESCRIPTION	QTY
1	7701301500101	CALIPER NAT. WITHOUT PADS	1
2	77013014000	BRAKE CALIPER SUPPORT FRONT 09	1
5	77013021000	REP. KIT SEALS 24MM	1
6	77013019000	REP. KIT PISTON 24MM	1
7	77013017000	BOLT CPL. 09	1
8	77013018000	RETAINING PLATE SET BREMBO	1
9	77013020000	BRAKE PADS TOYO B153	1
10	61013020100	BLEEDER SCREW WITH CAP	1
12	54613218000	CUP SET SHORT	1
15	0025080356S	HH COLLAR SCREW M8X35 TX40	2
21	59013011000	BRAKEHO. FRONT 1300MM 2000	1
30	0603100141	COPPER GASKET DIN7603-10X14X1	2
35	50213025000	HOLLOW SCREW M10X1X19	1

097701361 / C117801361

\* NEW PART

X AS REQUIRED

# REAR BRAKE CONTROL

250 EXC-F SIX DAYS EU 2013

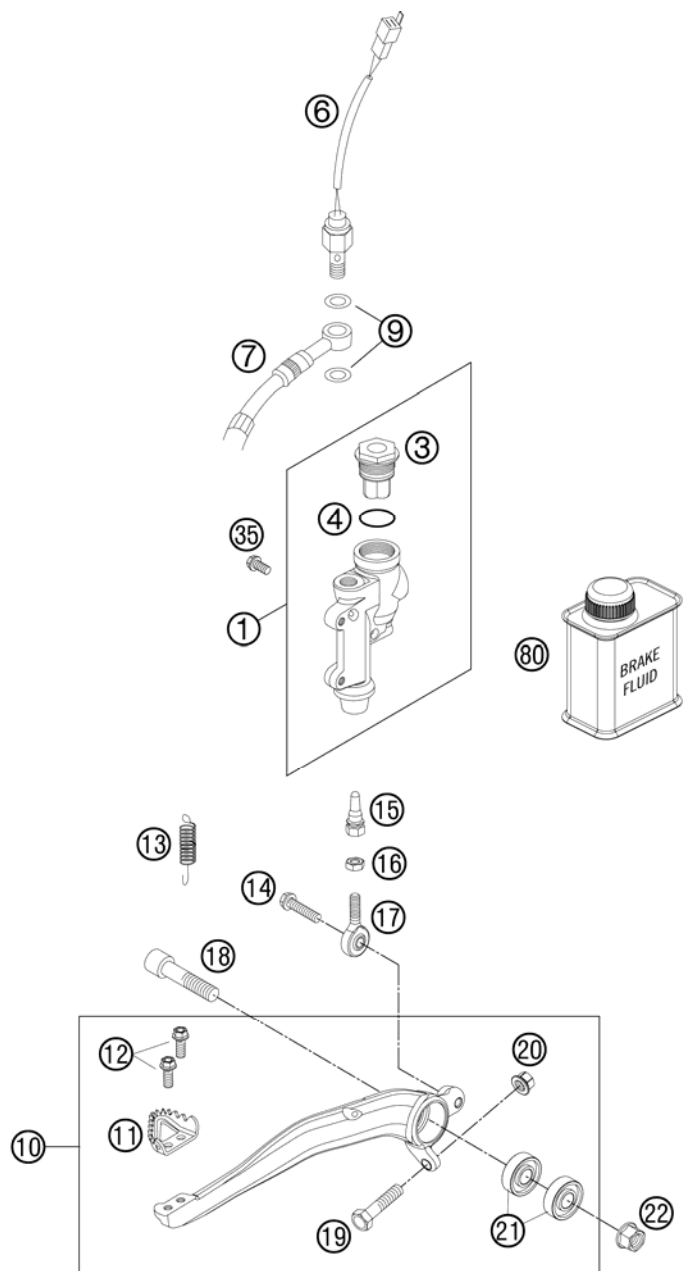

FIG	PART NUMBER	DESCRIPTION	QTY
1*	77013060044	REAR BRAKE CYLINDER CPL.SX 09	1
3	54813062100	REAR BRAKE CYL. COVER CPL. 04	1
4	54813063000	FOOT-BRAKE CYL. GASKET SX 03	1
6	50311051100	BRAKE LIGHT SWITCH REAR '98	1
7	54813070000	BRAKE HOSE REAR 655MM 03	1
9	0603100141	COPPER GASKET DIN7603-10X14X1	2
10	77213050044	FOOT BRAKE LEVER CPL.	1
11	54813051000	STEP PLATE FOR BRAKE LEVER	1
12	0025050126	HH COLLAR SCREW M5X12 TX30	2
13	54603062000	RETURN SPRING FOR BRAKE LEVER	1
14	0025060206	HH COLLAR SCREW M6X20 TX30	1
15	54813056000	PUSH ROD L=28MM 03	1
16*	0934060003	HEXAGON NUT DIN0934-M 6	1
17	54813055000	SWIVEL HEAD KA6 03	1
18*	0032100406S	AH-COLLAR SCREW M10X40 ISA45	1
19	59001037000	SPECIAL SCREW M8X26 WS=10	1
20	46030045000	COLLAR NUT M8 WS=10	1
21	0625060002	BALL BEARING SKF 6000-2RS1	2
22	54630044000	COLLAR NUT M10 WS=13	1
35	0025060126	HH COLLAR SCREW M6X12 TX30	2
80	00062030000	BRAKE FLUID DOT5.1 0,25L	1

137801330 / C135031330

\* NEW PART

X AS REQUIRED

# LIGHTING SYSTEM

250 EXC-F SIX DAYS EU 2013

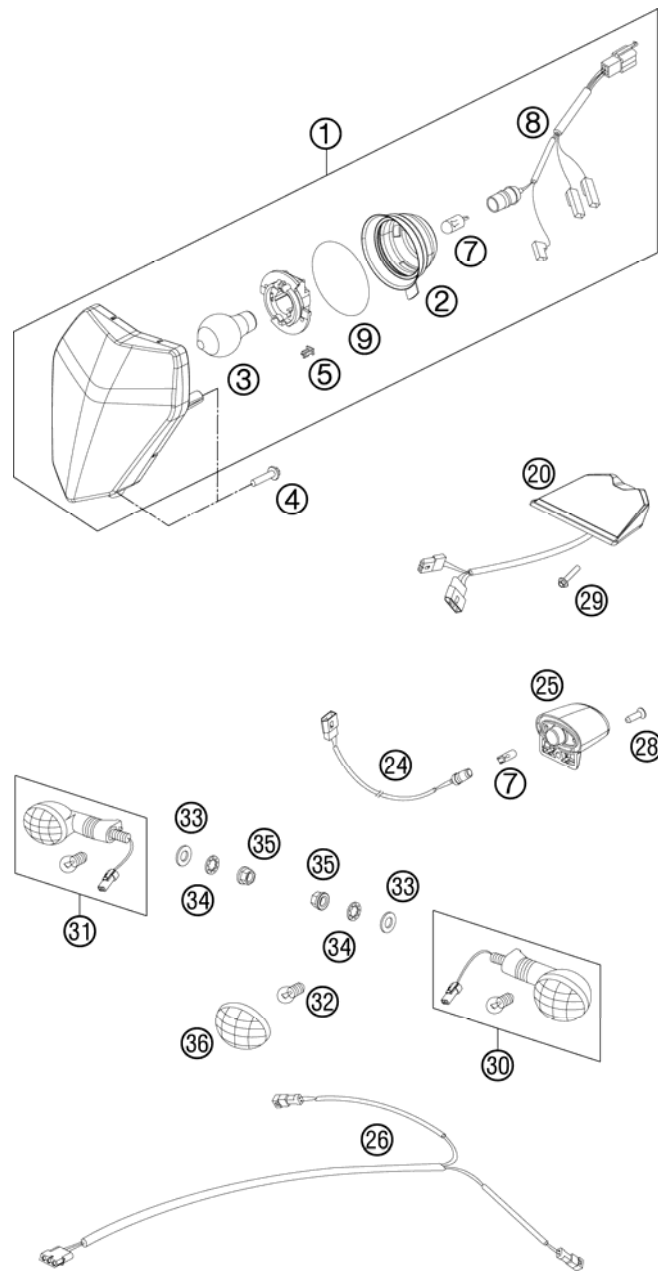

FIG	PART NUMBER	DESCRIPTION	QTY
1	78014001000	HEAD LIGHT CPL. EXC-EU 08	1
2	54814001050	RUBBER CAP FOR HEAD LIGHT 05	1
3	44111038000	BILUX-BULB 12V 35/35W BA20D	1
4	0081050181	SCREW FOR PLASTIC K50X18 T20	3
5	78014009000	DRAIN HOLE COVER	1
7	49011435100	BULB 12V 5W (W2,1X9,5D) PHIL.	2
8	54811001050	CABLE FOR HEAD LIGHT 2005	1
9	0770350032	O-RING 35,00X32,00 NBR	1
20	76514040000	REAR LIGHT	1
24	76511078000	WIRING HARN. LIC. PLATE ILLUM.	1
25	75014047000	LICENSE PLATE ILLUMINATION 07	1
26	77411081000	REAR FLASHER WIR. HARNESS 12	1
28	0081250181	SCREW FOR PLASTIC 50X18 T20	1
29	0017060253	EJOT PT SCREW K60X25-Z SW=6	2
30	54814025200	FLASHER CPL. FR.L/S RE.R/S 09	2
31	54814026200	FLASHER CPL. FR.R/S RE.L/S 09	2
32	44111015100	BULB 12V 10W (BA15S)	4
33	0125100003	WASHER DIN0125-A10,5	4
34	0797100003	LOCK WASHER DIN6797-J10,5 ZI	4
35	58414030000	HH COLLAR NUT M10X1,25 WS=13	4
36	54814028000	FLASHER LENS L/S R/S 05	4

127751410 / C127751410

\* NEW PART

X AS REQUIRED



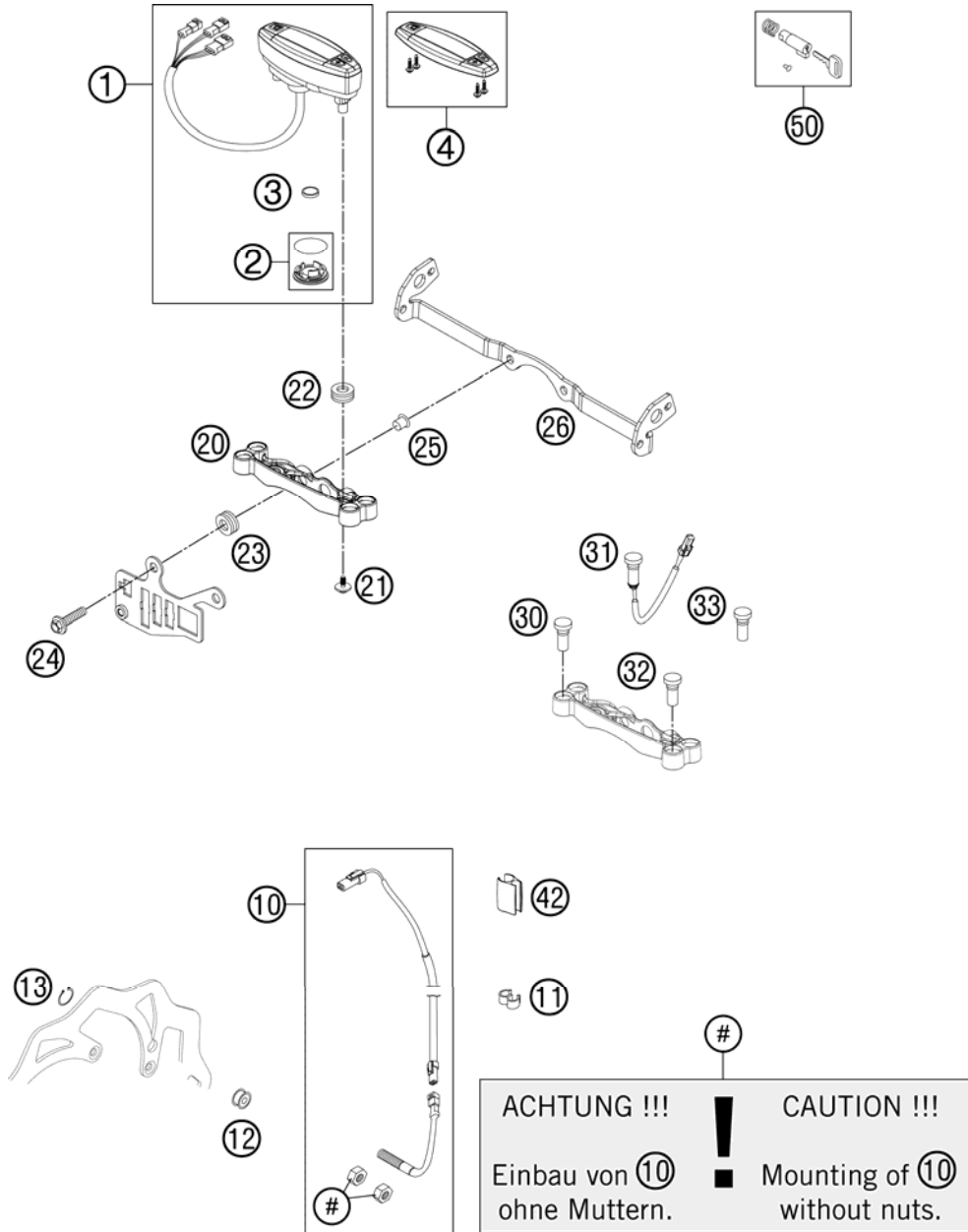

**ACHTUNG !!!**    **CAUTION !!!**  
**!**  
 Einbau von ⑩ ohne Muttern.    Mounting of ⑩ without nuts.

FIG	PART NUMBER	DESCRIPTION	QTY
1	54814069000	SPEEDOMETER KM/H F. 21" 2005 REPROGRAMMABLE: KM/H - MPH	1
2	54814069010	BATTERY COVER F. SPEEDOM. 2005	1
3	58314068000	BATTERY F. SPEEDOM. M.A.E. 02	1
4	54814069020	SPEEDOMETER TOP PART 05	1
10	54814068100	CABLE FOR DIGITAL SPEEDOM. 06	1
11	55011022100	CLAMP D=6/8MM, BLACK	3
12	54814069050	MAGNET FOR DIGITAL SPEEDOM. 03	1
13	0471009104	CIRCLIP DIN0471- 9X1 INOX	1
20	81214060000	SPEEDOMETER BRACKET	1
21*	0081645121	EJOT DELTA PT SCREW 45X12-Z	2
22	58214069051	RUBBER GROMMET 16X10,8X3 02	2
23	31008060000	RUBBER SLEEVE D=8MM OPEN	2
24*	0025060206	HH COLLAR SCREW M6X20 TX30	2
25*	59030060050	BUSHING F. SPROCKET COVER RAC.	2
26	78014033000	FLASHER BRACKET EXC 08	1
30	58011024300	FLASHER INDICAT.LIGHT GREEN'98	1
31*	81214083000	INDICATOR LIGHT LED YELLOW FI	1
32	58011021300	H.BEAM INDICATOR LIGHT BLUE'98	1
33*	81214086000	INDICATOR LIGHT RESERVE	1
42	54813026000	CABLE SUPPORT 10/6MM 06	2
50	78003035000	STEERING HEAD LOCK 08	1

127701430 / C137741432

\* NEW PART

X AS REQUIRED

①  
OHNE ABBILDUNG  
WITHOUT ILLUSTRATION

①  
TECHNISCHE DOKUMENTATION  
TECHNICAL DOCUMENTATION  
DOCUMENTACION TECNICA  
DOCUMENTATION TECHNIQUE  
NOTE TECNICHE

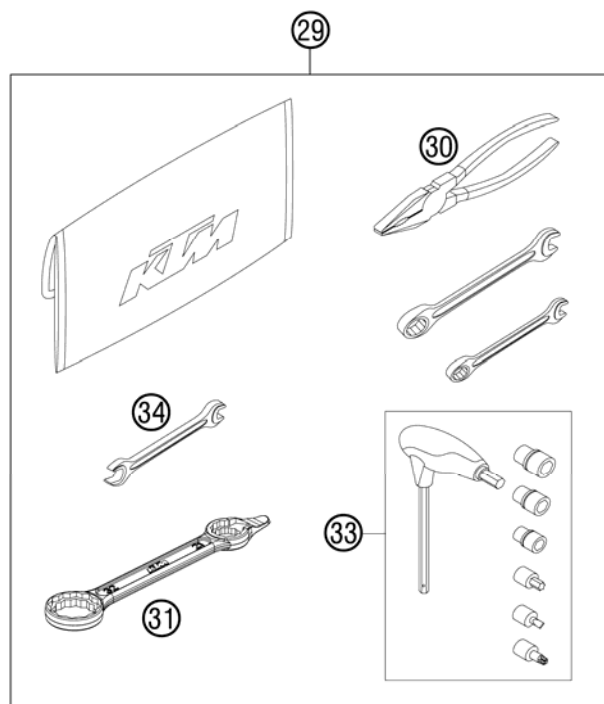

FIG	PART NUMBER	DESCRIPTION	QTY
0	00062030019	AIR FILTER OIL 100ML	1
0	00063004202	PRINT LABEL 60X51 MM	2
0	0019080206S	FLAT HEAD SCREW M. ISA45 M8X20	1
0	0025050126	HH COLLAR SCREW M5X12 TX30	2
0	0025060306	HH COLLAR SCREW M6X30 TX30	2
0	312305	DOCUMENTS BAG 2006	1
0	312313	KTM BALLPOINT PEN ORANGE	1
0	3210039	* CUSTOMER WELCOME LETTER	1
0	3212361DE/GB	PP OFFROAD FOLDER 2012	1
0	3212365GB	POWER WEAR TEASER 2012	1
0	50033029013	FRONT SPROCKET 13-T	1
0	50208020000	SPACER BUSHING 7X10X7,5	2
0	52000115	STICKER FRONT FORK-SET WP"4CS"	1
0	54809081060	FRONT AXLE PULL 26MM 04	1
0	58012040000	REAR MIRROR L/S	1
0	58012040150	CLAMP FOR MIRROR '94	2
0	58012140000	REAR MIRROR R/S	1
0	58411098100	CONTACT WASHER M6 VSV-K6	2
0	58412080000	REFLECTOR RED LC4 '98	1
0	77029072000	SPARK PLUG KEY 250 SX-F	1
0	77112099000	ACCESSORIES FLASHER	1
0	77202002144	BAR PAD CPL.	1
0	77203094000	PLASTIC FRAME PROTECTION SET	1
0	77235936000	RADIATOR PROTECTION CPL.	1
0	77311053000	BATTERY 12V 3AH YTX4L-BS	1
0	77403190000	ENGINE GUARD PLASTIC CPL.	1
0	77405009065	PLUG SCREW M12X1,25 WS17	1
0	78003040033	FOOTREST L/S + R/S CPL. 09	1
0	7810297900028	HANDGUARDS CPL.LE+RI WHITE 12	1
0	78108016050	NUMB.PLATE CARRIER BOTTOM	1
0	81212016100	WASH CAP SET	1
1	3211862EN	OWN.MAN.250 EXC-F/SD/XCF-W2013	1
29	54829099100	TOOL KIT 2012	1
30	53012028200	GRIP ORANGE B&F	1
31	50329080100	WRENCH SW=17/21/27/32 B&F	1

125482000 / C137742003

\* NEW PART

X AS REQUIRED

FIG	PART NUMBER	DESCRIPTION	QTY
33	60029070300	T-WRENCH WS=6/8/10/TX45/SK4X1	1
34	50329072000	SPOKE-SPANNER WS 7/10	1

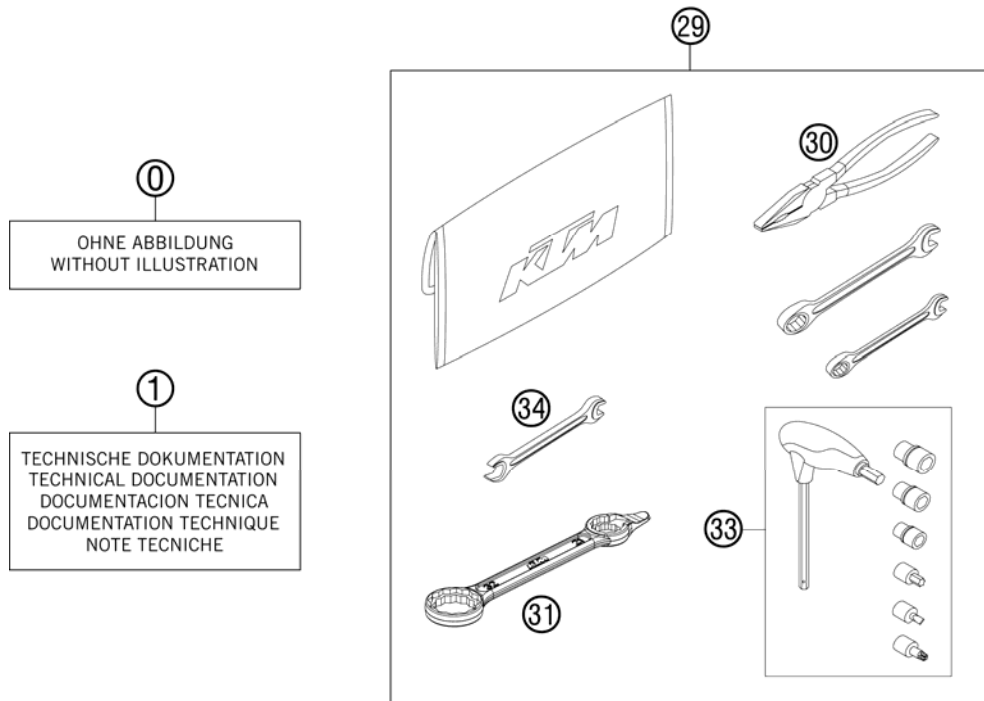

125482000 / C137742003

\* NEW PART

X AS REQUIRED

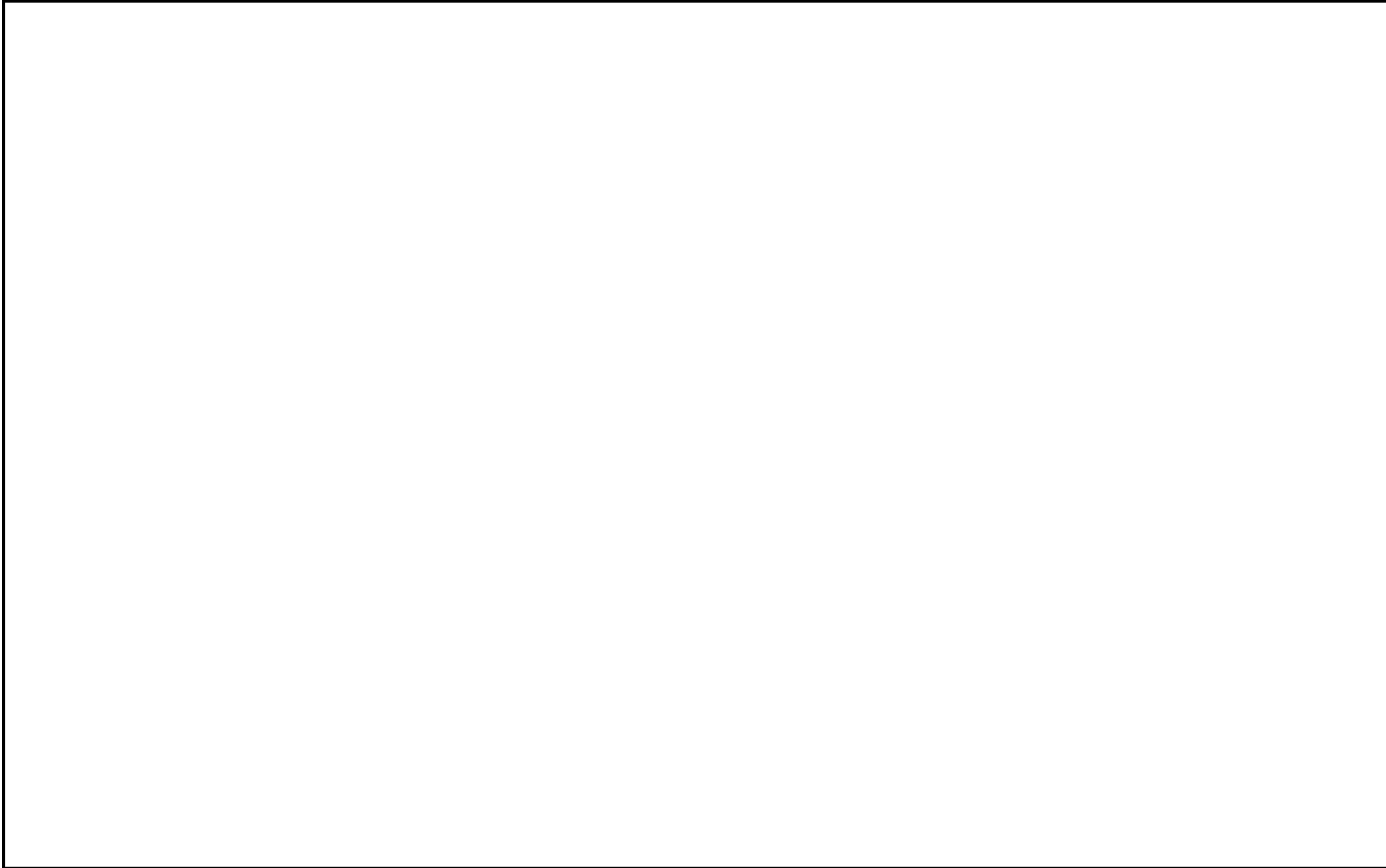

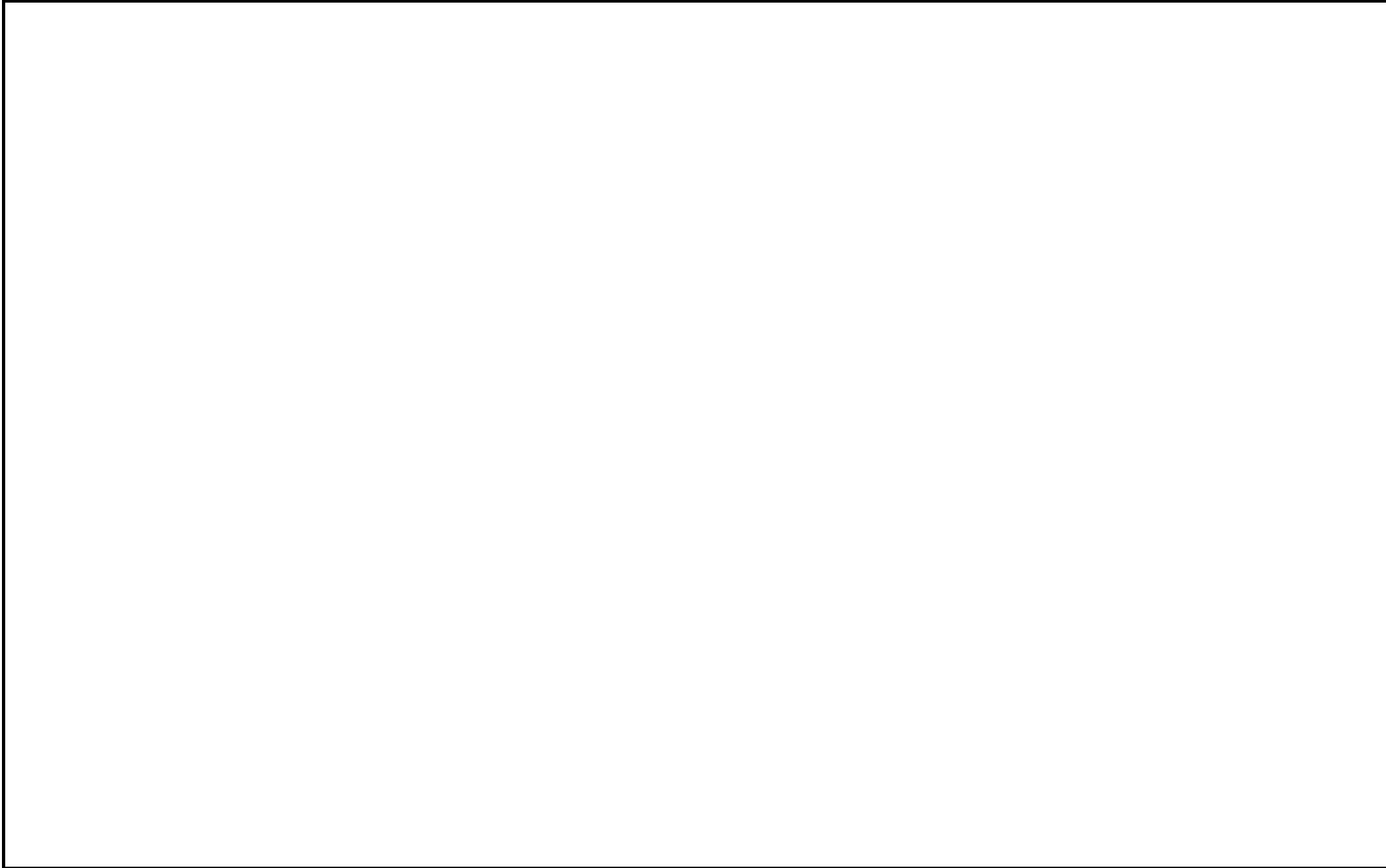







KTM-Sportmotorcycle AG  
A-5230 Mattighofen  
[www.ktm.at](http://www.ktm.at)

KTM Group Partner



3CFF8103M2EN



Art.Nr.: 3CFF8103M2EN 6/2012