

KTM POWERPARTS **INFORMATION**

TUNING KIT



76612945000
76612945100

03.2016
3.213.451



KTM AG
5230 Mattighofen, Austria
www.ktm.com



3 DEUTSCH

Wir freuen uns, dass Sie sich für dieses Produkt entschieden haben.

Unser hochwertiges Qualitätsprodukt ist rennerprobt und wurde speziell für sportliche Herausforderungen entwickelt. Eine korrekte Montage des Produktes ist unerlässlich, um ein Maximum an Sicherheit und Funktionalität gewährleisten zu können. Bitte befolgen Sie daher die Montageanleitung oder wenden Sie sich an Ihren autorisierten Fachhändler.

Für falsche Montage oder Verwendung dieses Produktes kann der (Quasi-)Hersteller bzw. Lieferant nicht zur Verantwortung gezogen werden.
Vielen Dank.

19 ENGLISH

Thank you for choosing this product.

Our high quality product has been tested under racing conditions and was developed specifically for use in sports activities. Correct installation of the product is essential to ensure that a maximum degree of safety and functionality is achieved. Therefore, please follow the installation instructions or contact your authorized dealer.

The (quasi) manufacturer or supplier cannot be held responsible for products that are incorrectly mounted or inappropriately used.
Thank you.

35 ITALIANO

Grazie per aver scelto questo prodotto.

Questo nostro prodotto di pregiata qualità è collaudato nelle competizioni ed è stato sviluppato specificamente per gare sportive. Il montaggio corretto del prodotto è fondamentale per garantirne la massima sicurezza e funzionalità. Rispetti quindi le istruzioni di montaggio o rivolgerti al proprio concessionario autorizzato.

Il produttore (detentore del marchio)/fornitore non può essere considerato responsabile per un montaggio o impiego errato del presente prodotto.
Vi ringraziamo per l'attenzione!

51 FRANÇAIS

Merci d'avoir porté votre choix sur ce produit.

Notre produit de haute qualité est éprouvé pour les compétitions et a été conçu spécialement pour un usage sportif. Un montage approprié du produit est indispensable pour garantir une sécurité et une fonctionnalité maximales du véhicule. C'est pourquoi nous vous invitons à suivre scrupuleusement le manuel de montage ou à vous adresser à votre revendeur agréé.

En cas de montage ou d'utilisation non conformes de ce produit, le (quasi) constructeur ou le fournisseur déclinent toute responsabilité.
Merci !

67 ESPAÑOL

Le agradecemos que se haya decidido por este producto.

Este producto de alta calidad está probado para la competición y se ha desarrollado específicamente para las exigencias de este deporte. Para poder garantizar los máximos niveles de seguridad y funcionalidad, es imprescindible que el producto se monte correctamente. Por este motivo, es muy importante que siga las instrucciones del manual de montaje o que se ponga en contacto con su concesionario autorizado.

El (cuasi) fabricante y el proveedor de este producto no se harán responsables del montaje y el uso incorrectos.
¡Muchas gracias!

Wir raten Ihnen, die Montage des Tuningkits nur von einer autorisierten Fachwerkstätte bzw. einem qualifizierten Servicetechniker durchführen zu lassen! Unsachgemäße Montage kann zu einer kürzeren Lebensdauer bzw. Schaden am Motorrad führen!



Lieferumfang 76612945000 (nur 690 Duke)

- | | |
|----------------------------|-------------|
| 1x AKRAPOVIC Enddämpfer ① | 76005979200 |
| 1x Carbon Auspuffschelle ② | |
| 2x Auspufffeder lang ③ | |
| 1x Montagekit A | |

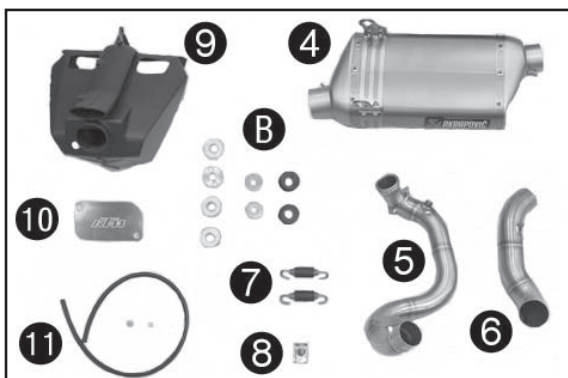

Lieferumfang 76612945000 und 76612945100

- | | |
|------------------------------|-------------|
| AKRAPOVIC EVO Krümmer Set | 76005907100 |
| 1x Vorschalldämpfer ④ | |
| 1x Krümmer ⑤ | |
| 1x Krümmerrohr ⑥ | |
| 2x Auspufffeder kurz ⑦ | |
| 1x Blechmutter ⑧ | |
| 1x Montagekit B | |
| 1x Tuning Luftfilterkasten ⑨ | 76006901000 |
| 1x SLS Verschlussdeckel ⑩ | 60005022200 |
| 1x EVAP Demontagekit ⑪ | 76015999044 |



⚠ ACHTUNG

Dieser Tuningkit besitzt keine Straßenzulassung!

Die Anlage darf nur in Kombination mit dem speziellen AKRAPOVIC EFI-Mapping verbaut und betrieben werden. Das Mapping muss vor dem erstmaligem Betrieb bei einem Vertragshändler installiert werden!

- | | |
|--------------------------------------|-------------|
| - AKRAPOVIC EFI-Mapping (690 Duke) | 76641033131 |
| - AKRAPOVIC EFI-Mapping (690 Duke R) | 76641033132 |

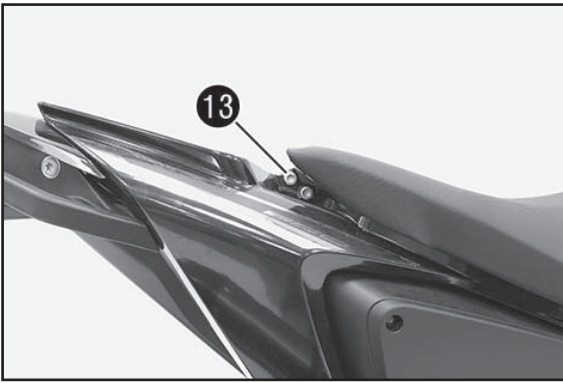

Vorarbeit

- Motorrad mit Hebevorrichtung hinten aufnehmen (s. Bedienungsanleitung).
- Beifahrersitzbank abnehmen (s. Bedienungsanleitung).
- Batterie abklemmen (s. Bedienungsanleitung).

Fahrersitz abnehmen

- Schraube 13 entfernen.
- Die Sitzbank hinten anheben, zurückziehen und nach oben abnehmen.

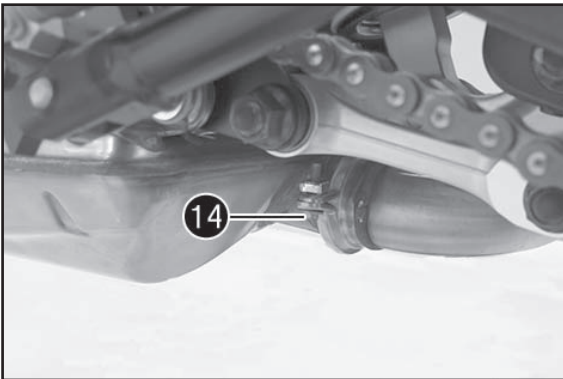

Enddämpfer ausbauen

! Warnung
Verbrennungsgefahr

Die Auspuffanlage wird beim Betrieb des Fahrzeugs sehr heiß.
- Auspuffanlage abkühlen lassen. Heiße Teile nicht berühren.

- Schraube 14 entfernen. Schelle des Enddämpfers abnehmen.

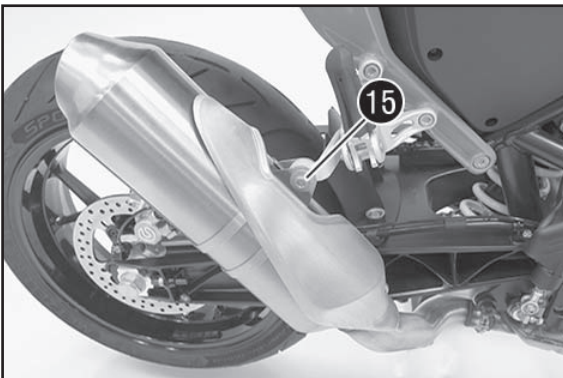

(Duke)

- Schraube 15 mit Scheibe entfernen.
- Enddämpfer abnehmen.

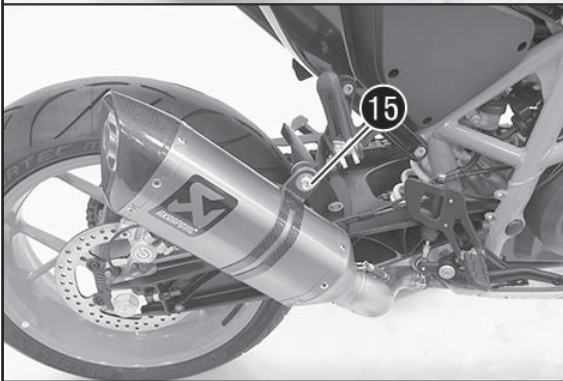

(Duke R)

- Schraube 15 mit Scheibe entfernen.
- Enddämpfer abnehmen.

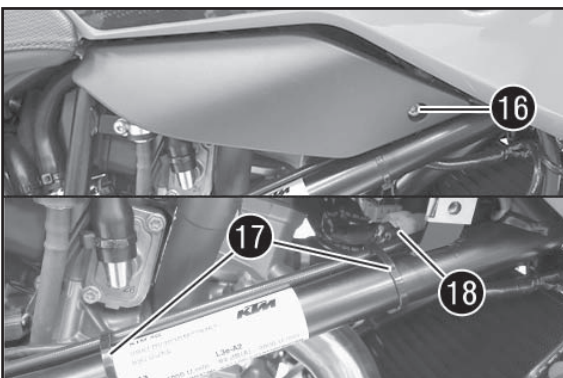

Auspuffanlage ausbauen

- Schraube 16 beidseitig entfernen. Rechte und linke Verkleidung entfernen.
- Die Kabelbinder 17 entfernen. Steckerverbindung 18 der Lambdasonde trennen.

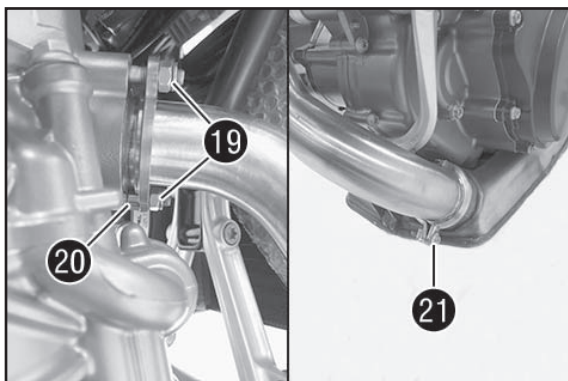

- Muttern 19 entfernen.

HINWEIS

Distanzbuchse 20 nicht verlieren.

- Schraube 21 entfernen. Schelle abnehmen.
- Krümmer und Dichtung entfernen.

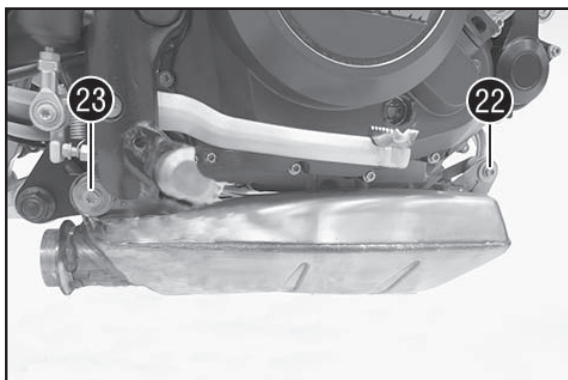

- Schraube 22 mit Scheibe entfernen.
- Schrauben 23 beidseitig entfernen.
- Vorschalldämpfer abnehmen.

Tank ausbauen



Gefahr

Brandgefahr Kraftstoff ist leicht entflammbar

- Fahrzeug nicht in der Nähe von offenen Flammen bzw. brennenden Zigaretten tanken und den Motor immer abstellen. Darauf achten, dass kein Kraftstoff insbesondere auf heiße Teile des Fahrzeugs verschüttet wird. Verschütteten Kraftstoff sofort aufwischen.
- Der im Kraftstofftank vorhandene Kraftstoff dehnt sich bei Erwärmung aus und kann bei Überfüllung austreten. Angaben zum Kraftstofftanken beachten.



Warnung

Vergiftungsgefahr Kraftstoff ist giftig und gesundheitsschädlich

- Kraftstoff nicht mit Haut, Augen und Kleidung in Berührung bringen. Kraftstoffdämpfe nicht einatmen. Bei Augenkontakt sofort mit Wasser spülen und einen Arzt aufsuchen. Kontaminierte Hautstellen sofort mit Wasser und Seife reinigen. Wurde Kraftstoff verschluckt sofort einen Arzt aufsuchen. Mit Kraftstoff kontaminierte Bekleidung wechseln. Kraftstoff ordnungsgemäß in einem geeigneten Kanister aufbewahren und von Kindern fernhalten.

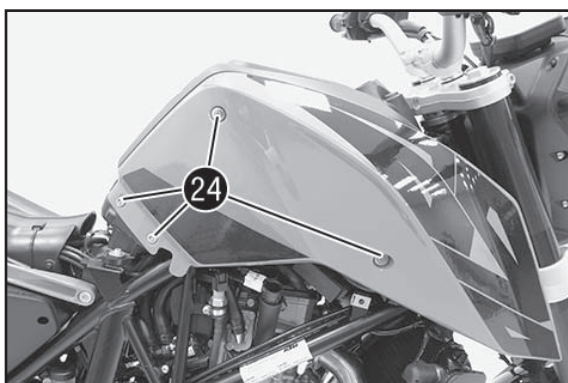

- Schrauben 24 entfernen.
- Spoiler rechts abnehmen.

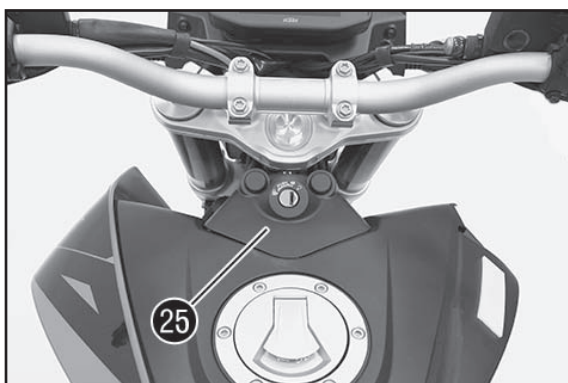

- Verkleidung 25 nach oben ziehen und abnehmen.

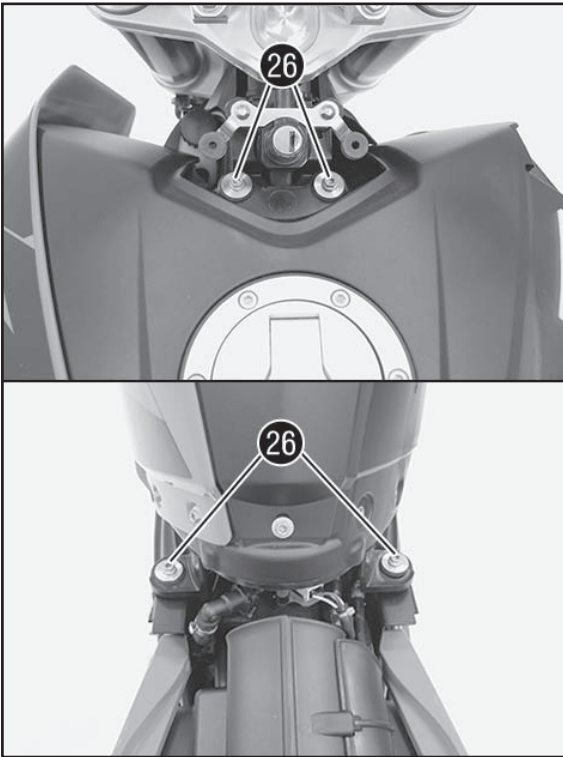

- Schrauben 26 entfernen.

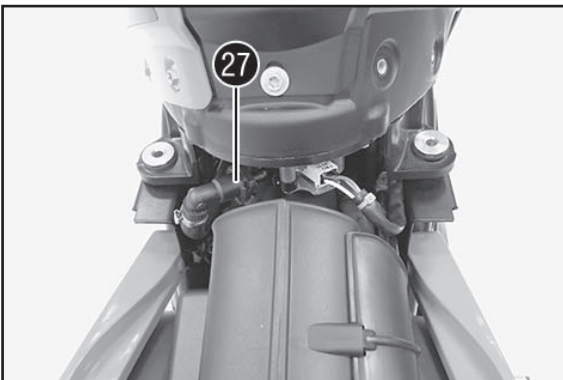

- Kraftstoffschlauchverbindung 27 trennen.

HINWEIS

Aus dem Kraftstoffschlauch kann ein Rest Kraftstoff auslaufen.

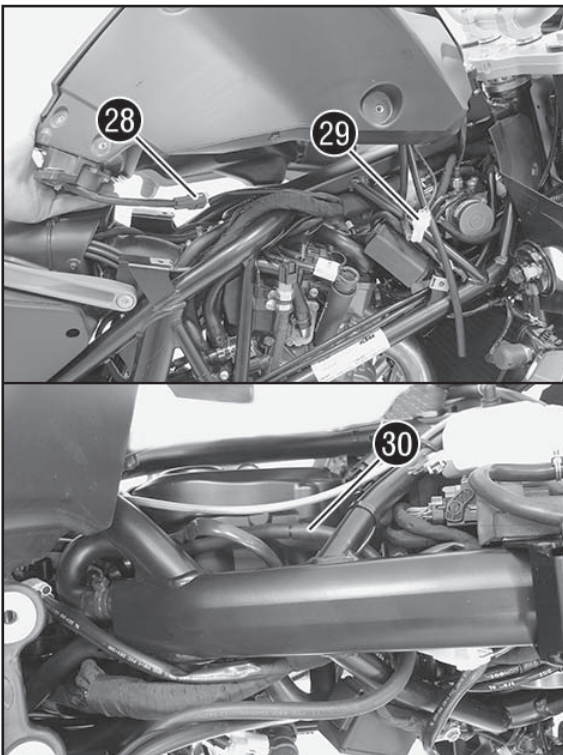

- Kraftstofftank anheben.
- Steckerverbindung 28 trennen.
- Steckerverbindung 29 trennen.

(Duke)

- Entlüftungsschlauch 30 abziehen.
- Kraftstofftank abnehmen.

(Duke R)

- Entlüftungsschläuche 30 abziehen.
- Kraftstofftank abnehmen.

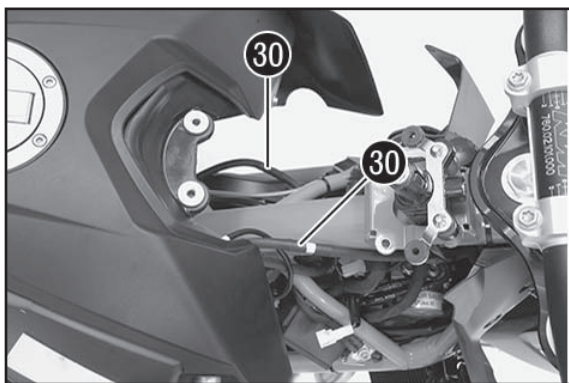

Luftfilterkasten ausbauen

- Schrauben 31 entfernen.
- Luftfilterkastendeckel abnehmen.

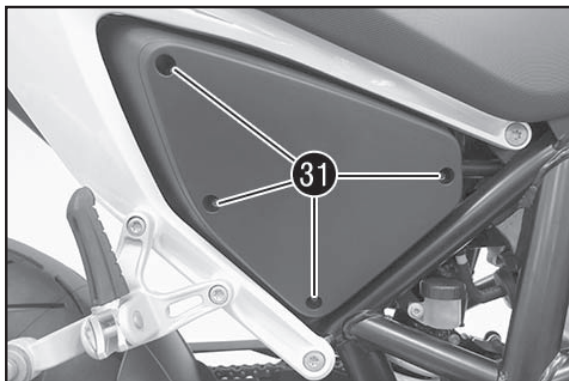

- Luftfilterhaltebügel 32 aushängen und zur Seite schwenken.

- Filterrahmen 33 und Luftfilter 34 entfernen.

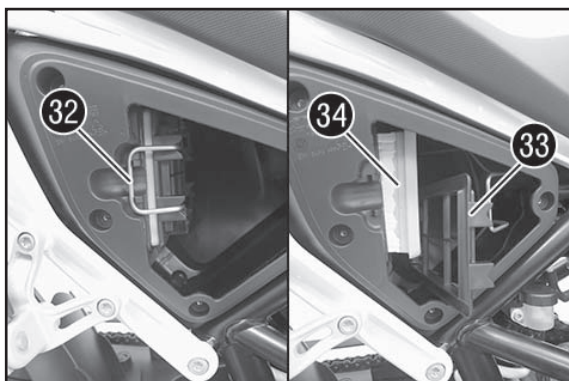

- Schrauben 35 entfernen.
- Beifahrer-Fußrastenträger abnehmen.
- Schrauben 36 entfernen.
- Schraube 37 entfernen.
- Schraube 38 entfernen.

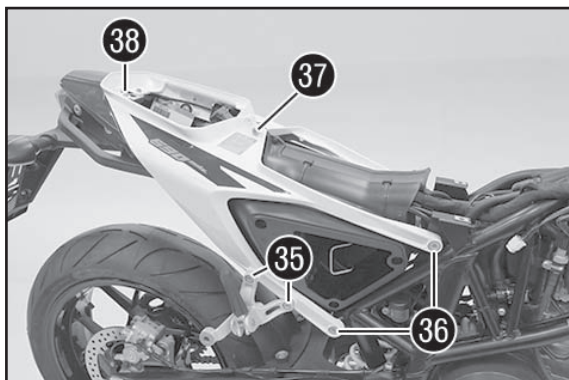

- Schrauben 39 beidseitig entfernen.
- Haltegriffe abnehmen.

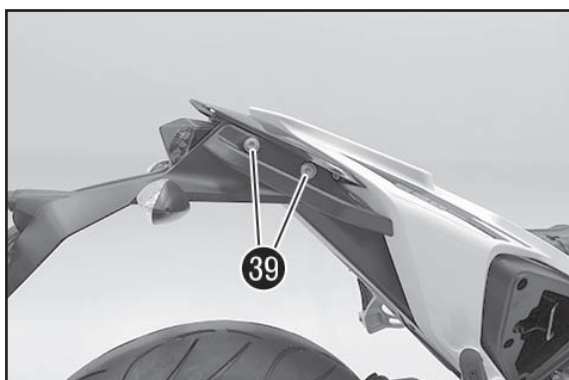

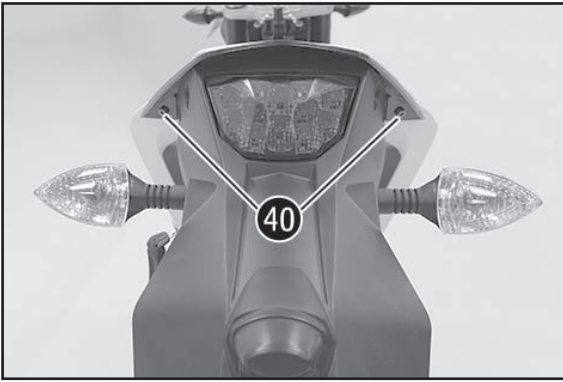

- Schrauben 40 entfernen.
- Heckabdeckung abnehmen.

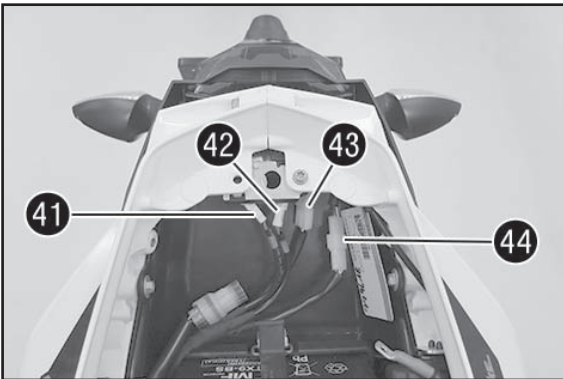

- Steckerverbindung 41 trennen.
- Steckerverbindung 42 trennen.
- Steckerverbindung 43 trennen.
- Steckerverbindung 44 trennen.
- Kabel ausfädeln und Kennzeichenträger abnehmen.

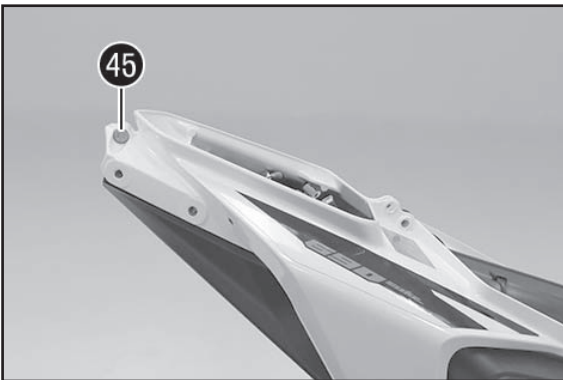

- Schraube 45 entfernen.

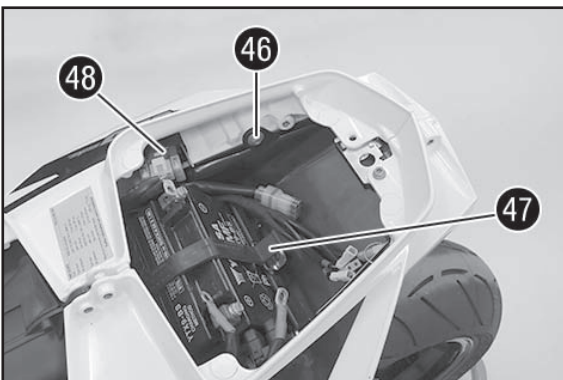

- Schraube 46 entfernen.
- Haltegummi 47 aushängen.
- Batterie nach oben aus dem Batteriehalter entfernen.
- Startrelais 49 vom Halteblech abziehen.

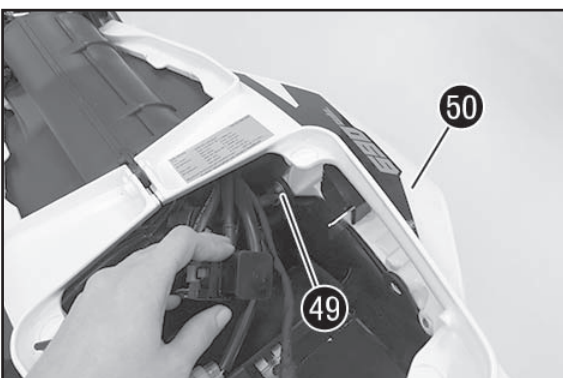

- Schraube 49 entfernen.
- Rechtes Heckteil 50 entfernen.

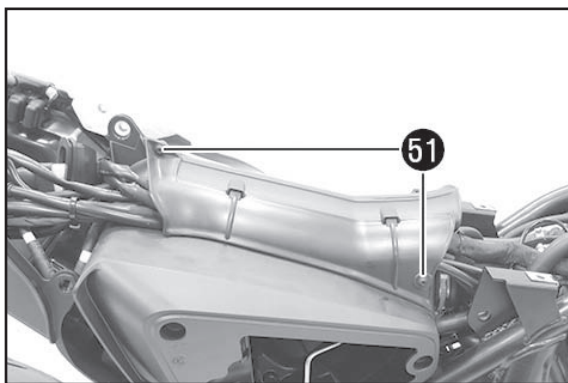

- Schrauben 51 entfernen.
- Rechte Kabelabdeckung entfernen.

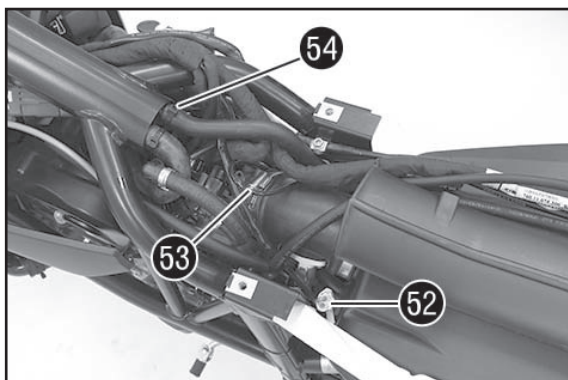

- Steckerverbindung 52 trennen.
- Schlauchschelle 53 lösen.
- Kabelbinder 54 entfernen.
- Entlüftungsschlauch abziehen.

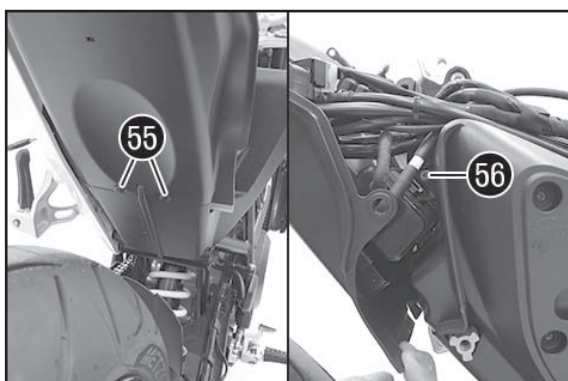

- Stopfen 55 entfernen.
- Schraube 56 entfernen.

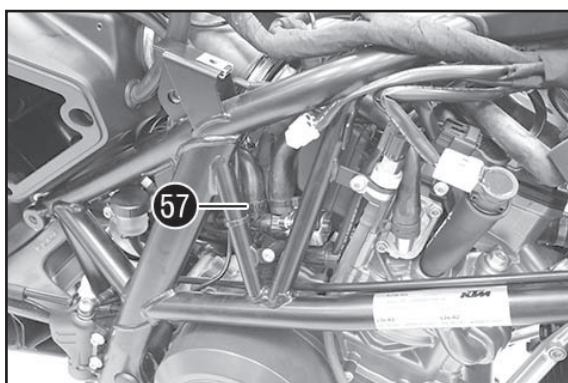

- Kabelbinder 57 entfernen.
- SLS-Schlauch abziehen.

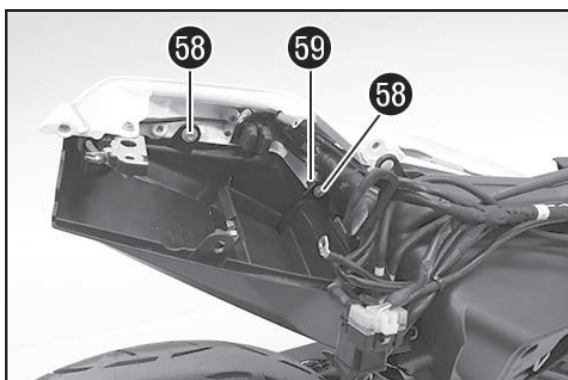

- Schrauben 58 entfernen.
- Seilzughalter Sitzbankschloss 59 entfernen.
- Batteriehalter abnehmen.

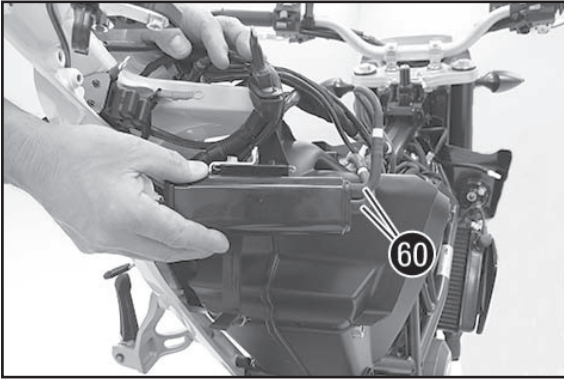

- Schläuche 60 abziehen.
- Aktivkohlefilter entfernen.

HINWEIS
Aktivkohlefilter wird nicht wieder verbaut.

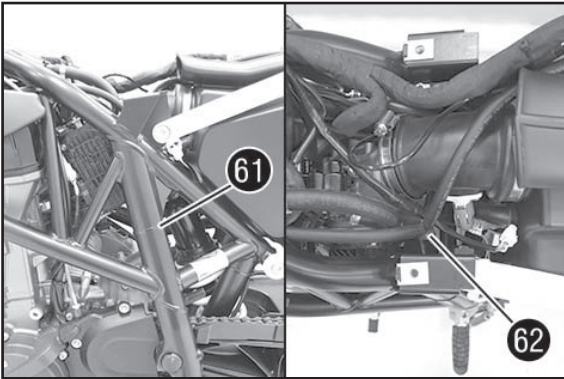

- Kabelbinder 61 entfernen.
- Y-Stück 62 mit Schläuchen entfernen.

HINWEIS
Schläuche werden nicht wieder eingebaut.

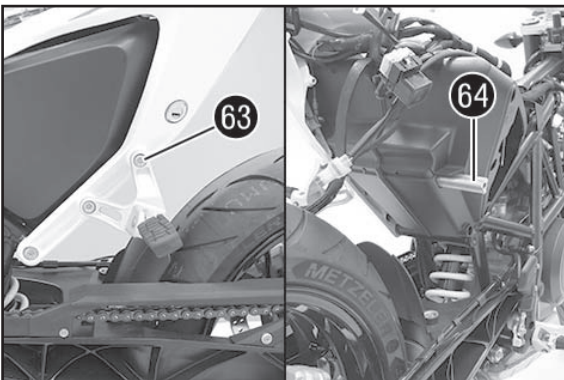

- Schraube 63 entfernen.
- Hülse 64 nach rechts entfernen.



- Luftfilterkasten entfernen.

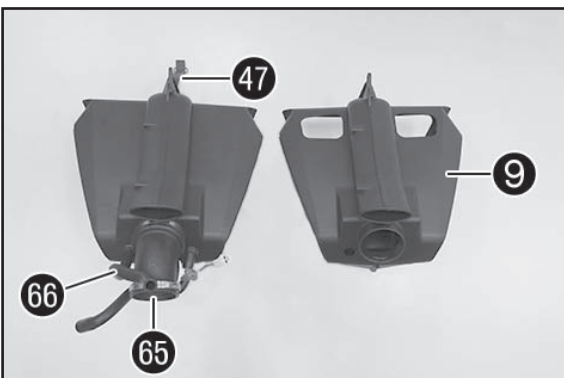

Vormontage Luftfilterkasten

- Haltegummi 47, Ansaugtrichter 65 mit Schlauchschelle und Entlüftungsschlauch 66 vom Original-Luftfilterkasten auf Luftfilterkasten 9 (Lieferumfang) ummontieren.

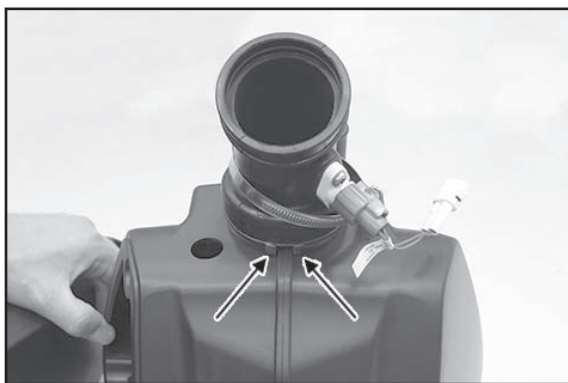

HINWEIS

Ansaugtrichter wie abgebildet montieren.

- ✓ Haltenasen positionieren den Ansaugtrichter am Steg (s.Pfeil).

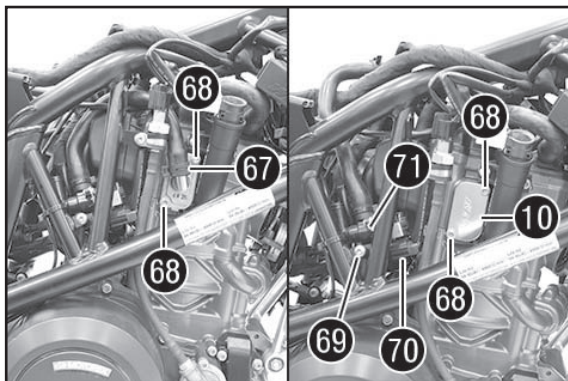

SLS Demontage

- Federbandschelle 67 lösen und SLS-Schlauch abziehen.
- Schrauben 68 entfernen.
- Deckel abnehmen.
- SLS-Deckel 10 (Lieferumfang) positionieren.
- Original-Schrauben 68 montieren und mit 10 Nm festziehen.
- Schraube 69 entfernen.
- Stecker 70 abstecken, Kabel spannungsfrei verlegen und mit Kabelbinder am Kabelstrang sichern.
- SLS-Ventil 71 mit Schlauch entfernen.

HINWEIS

SLS-Ventil wird nicht wieder verbaut.

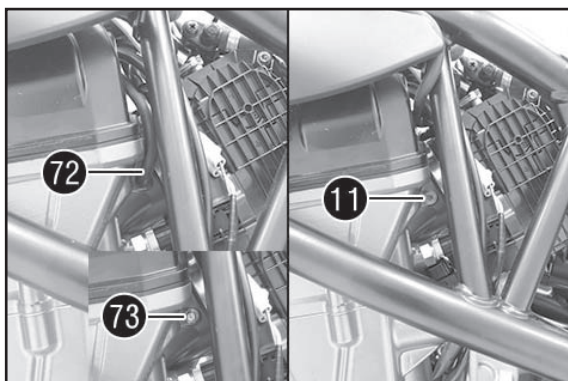

EVAP Demontagekit

- Schlauch 72 auf der linken Seite abziehen.
- Ventil 73 entfernen.

HINWEIS

Schlauch und Ventil werden nicht wieder verbaut.

- Schraube mit Dichtring 11 (beides Lieferumfang) montieren und mit 10 Nm festziehen (Loctite 243).

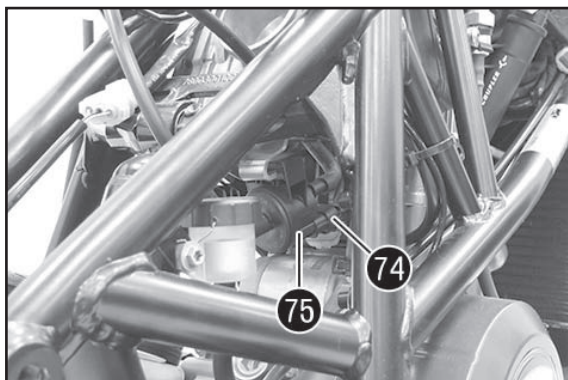

- Stecker 74 abstecken, Kabel spannungsfrei verlegen und mit Kabelbinder am Kabelstrang sichern.
- Kraftstoffverdunstungsventil oder EVAP Ventil??? 75 vom Halteblech abziehen und mit Schläuchen entfernen.

HINWEIS

EVAP Ventil wird nicht wieder verbaut.

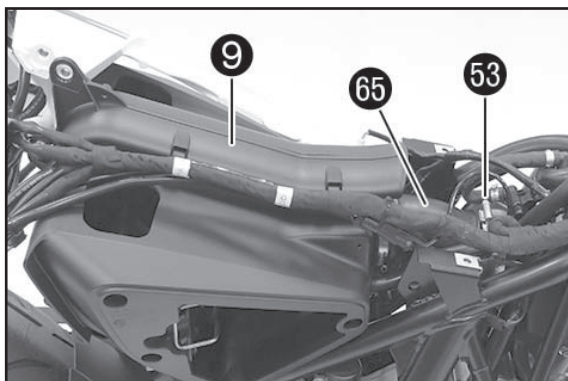

Luftfilterkasten einbauen

- Luftfilterkasten 9 (Lieferumfang) positionieren.
- Ansaugtrichter 65 montieren.
- Schlauchschelle 53 positionieren und festziehen.

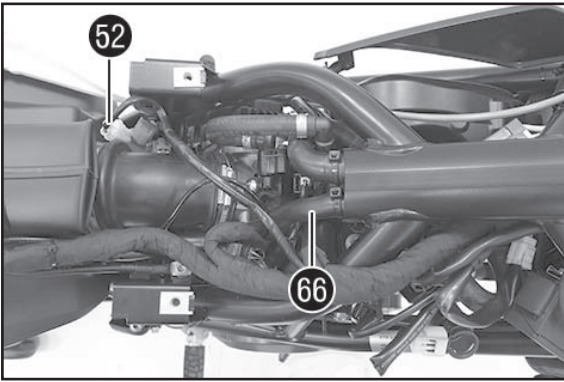

- Steckerverbindung 52 zusammenstecken.
- Entlüftungsschlauch 66 montieren und mit Kabelbinder sichern.

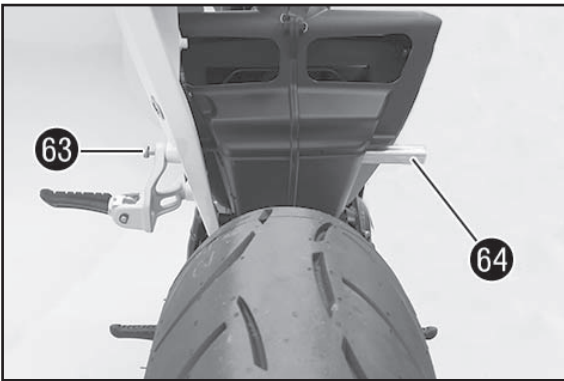

- Original-Hülse 64 montieren.
- Original-Schraube 63 montieren, aber noch nicht festziehen.

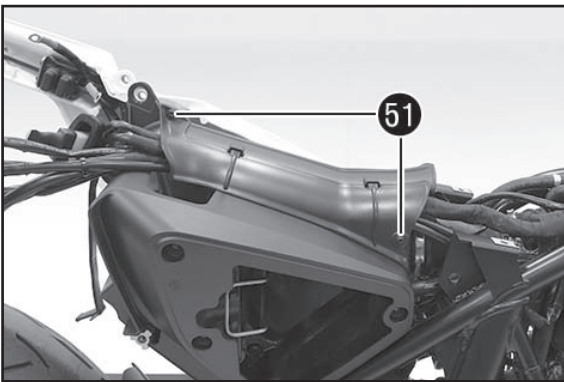

- Kabelabdeckung rechts positionieren.
- Original-Schrauben 51 montieren und festziehen.

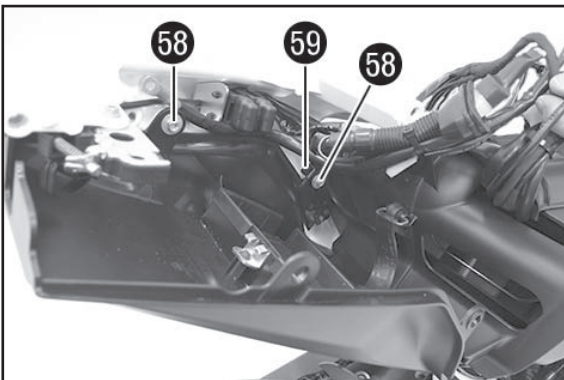

- Batteriehalter positionieren.
 - Seilzughalter Sitzbankschloss 59 positionieren und Seilzug einhängen.
- HINWEIS
Seilzughalter wird vorn positioniert.

- Original-Schrauben 58 montieren und mit 10 Nm festziehen.



- Original-Stopfen 55 montieren.

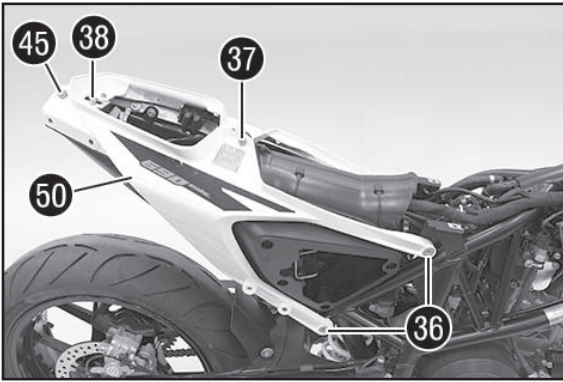

- Rechtes Heckteil 50 positionieren.
- Original-Schrauben 36, 37, 38 montieren, aber noch nicht festziehen.
- Original-Schraube 45 montieren und mit 25 Nm festziehen (Loctite 243).
- Schrauben 36 mit 45 Nm festziehen.
- Schraube 37 mit 25 Nm festziehen (Loctite 243).
- Schraube 38 mit 10 Nm festziehen (Loctite 243).

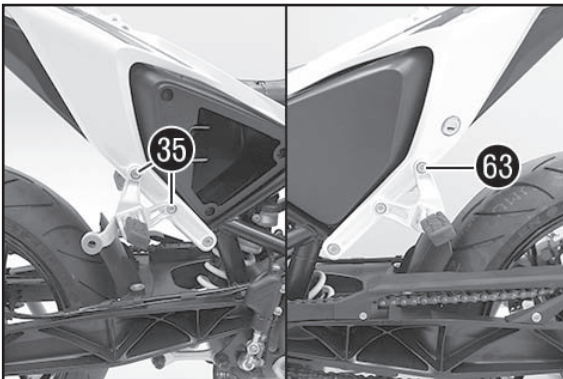

- Beifahrer-Fußrastenträger positionieren.
- Original-Schrauben 35 montieren und mit 25 Nm festziehen (Loctite 243).
- Original-Schraube 63 montieren und mit 25 Nm festziehen (Loctite 243).

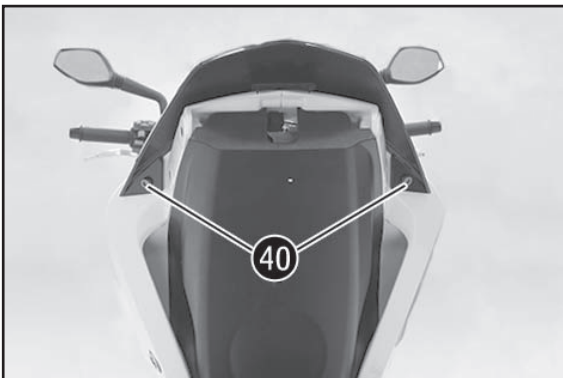

- Heckabdeckung positionieren.
- Original-Schrauben 40 montieren und mit 10 Nm festziehen.

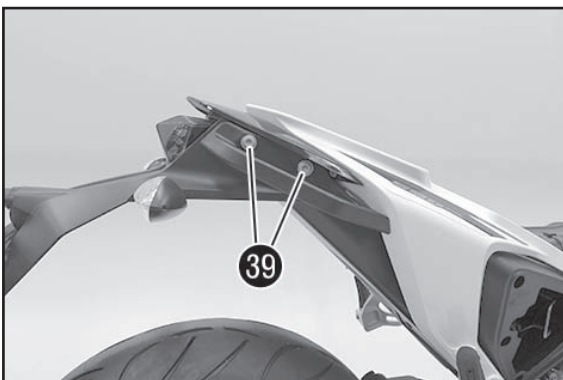

- Kabel einfädeln und Kennzeichenträger positionieren.
- Haltegriffe positionieren.
- Original-Schrauben 39 montieren und mit 18 Nm festziehen (Loctite 243).

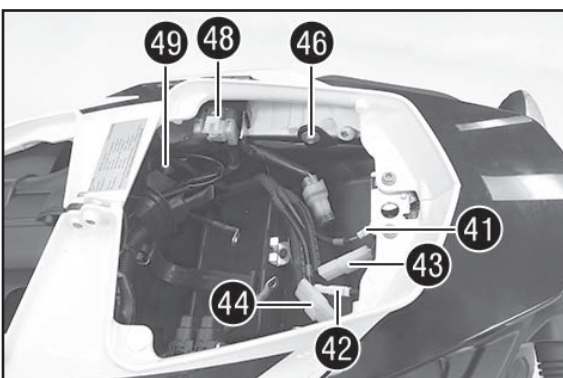

- Steckerverbindung 41 zusammenstecken.
- Steckerverbindung 42 zusammenstecken.
- Steckerverbindung 43 zusammenstecken.
- Steckerverbindung 44 zusammenstecken.
- Original-Schraube 46 montieren und mit 10 Nm festziehen.
- Original-Schraube 49 montieren und mit 10 Nm festziehen.
- Startrelais 48 am Halteblech montieren.

! VORSICHT

Alle Kabel ordnungsgemäß verlegen und ggf. mit Kabelbinder fixieren. Sicherstellen, dass die Kabel nicht geknickt oder geklemmt werden!

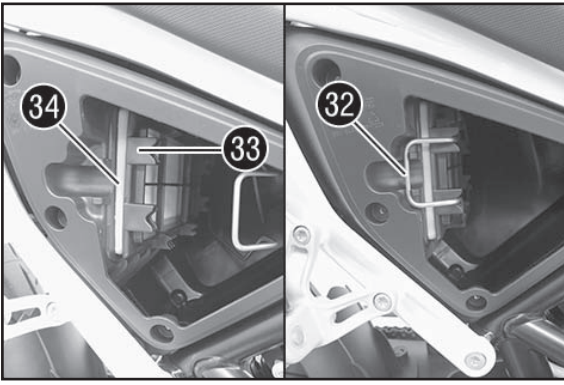

- Luftfilter 34 und Filterrahmen 33 positionieren.
- Luftfilterhaltebügel 32 positionieren und einhängen.

HINWEIS

Der Haltebügel muss rundherum in den Aussparungen des Filterrahmens liegen.

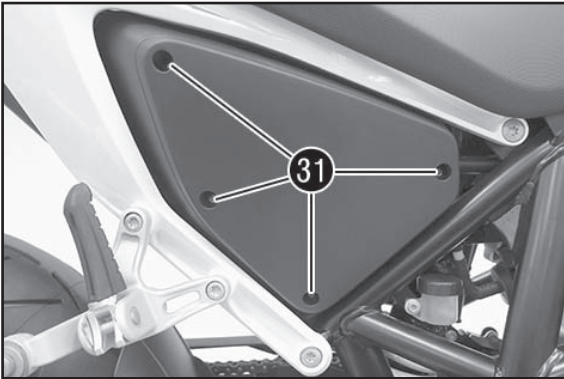

- Luftfilterkastendeckel montieren.
- Original-Schrauben 31 montieren und mit 3 Nm festziehen.

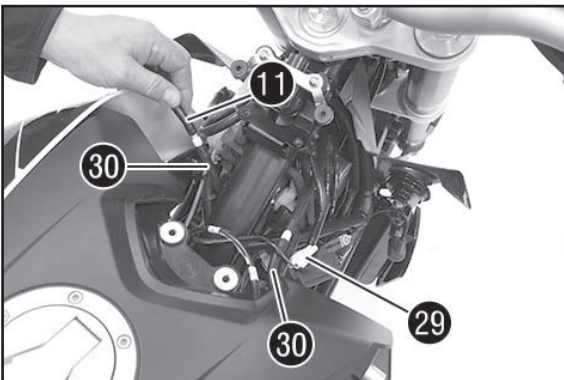

Tank einbauen

- Tank aufheben.
- Steckerverbindung 29 zusammenstecken.
- Entlüftungsschlauch 30 montieren.
- Entlüftungsschlauch 30 zur anderen Seite durchfädeln.
- Entlüftungsschlauch 11 (Lieferumfang) montieren.

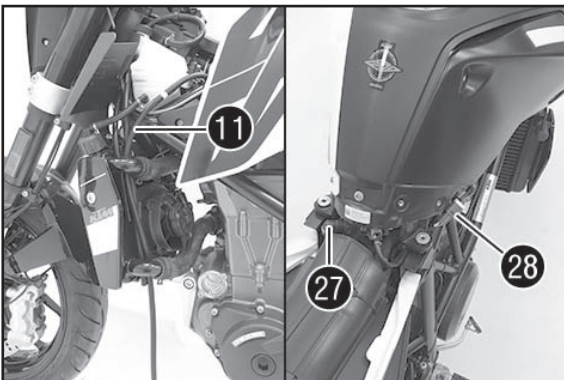

- Entlüftungsschlauch 11 spannungsfrei nach unten verlegen.
- HINWEIS**
Wenn der Schlauch zu lang ist, muss dieser eingekürzt werden.

- Tank positionieren.
- Kraftstoffschlauchverbindung 27 mit neuem O-Ring zusammenstecken.
- Steckerverbindung 28 zusammenstecken.



- Original-Schrauben 26 montieren und mit 10 Nm festziehen.

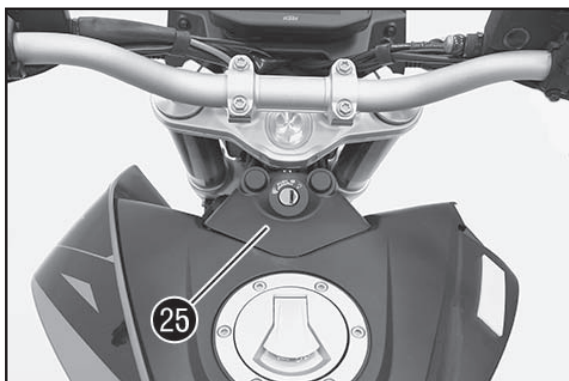

- Verkleidung 25 montieren.

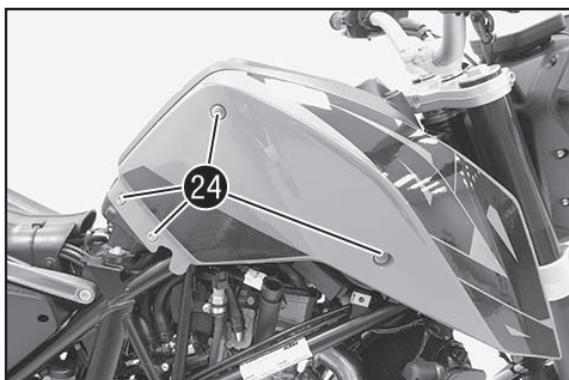

- Spoiler positionieren.
- Original-Schrauben 24 montieren und mit 3 Nm festziehen.

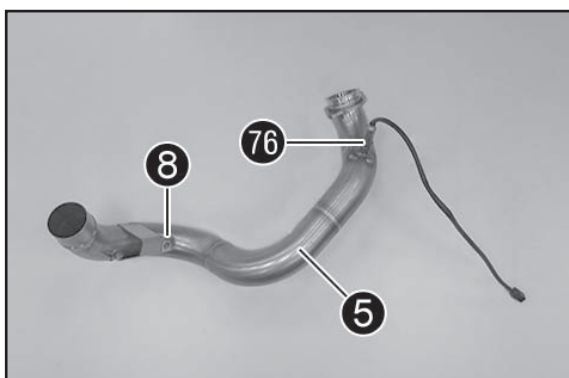

Vormontage Krümmer

- Lambdasonde 76 vom Original-Krümmer auf Krümmer 5 (Lieferumfang) ummontieren.
- Mehrbereichsblechmutter 8 (Lieferumfang) montieren.

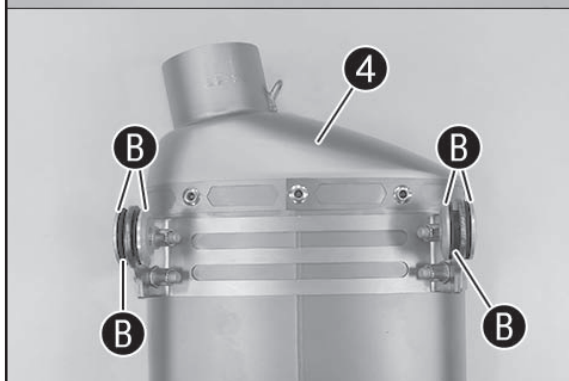

- Gummibuchsen (Lieferumfang Montagekit B) an Halter des Vorschalldämpfers 4 (Lieferumfang) montieren.
- Silberne Buchsen (Lieferumfang Montagekit B) links und rechts auf Gummibuchsen montieren.

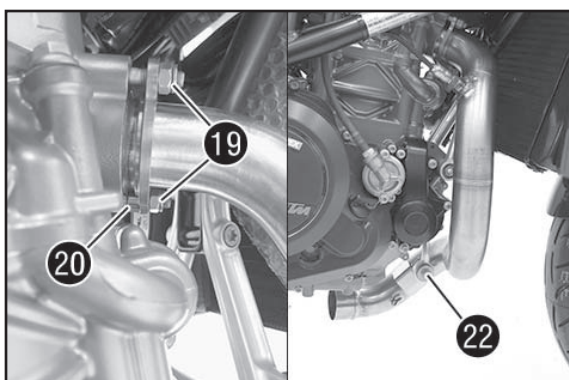

Auspuffanlage einbauen

- Krümmer 5 (Lieferumfang) mit Dichtung positionieren.
- Original-Muttern 19 mit Distanzbuchse 20 montieren, aber noch nicht festziehen.

- Original-Schraube 22 mit Scheibe montieren, aber noch nicht festziehen.

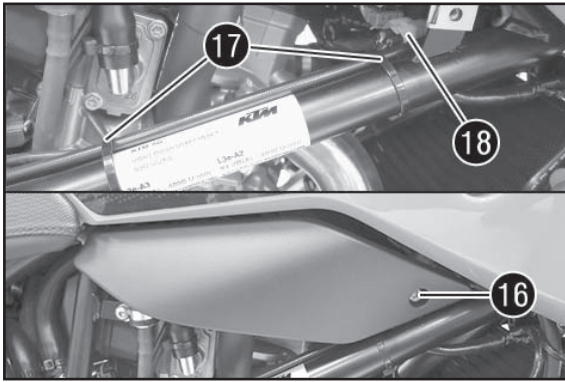

- Steckerverbindung 18 der Lambdasonde zusammenstecken. Kabel mit Kabelbindern 17 sichern.
- Rechte und linke Verkleidung montieren.
- Original-Schrauben 16 beidseitig montieren und mit 3 Nm festziehen.

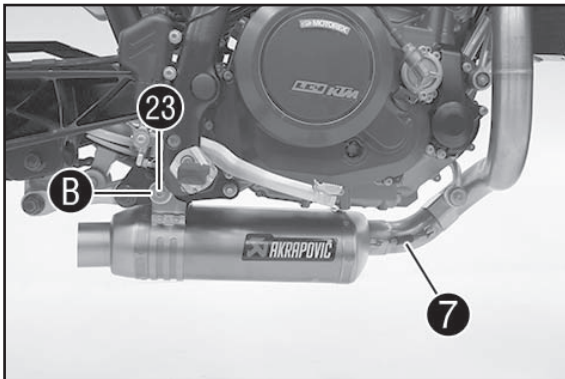

- Vorschalldämpfer 4 (Lieferumfang) positionieren.
- Original-Schrauben 23 mit Scheiben (Lieferumfang Montagekit B) beidseitig montieren, aber noch nicht festziehen.
- Auspufffeder kurz 7 (Lieferumfang) montieren.
- Muttern 19 gleichmäßig mit 20 Nm festziehen (Kupferpaste).
- Schraube 22 mit 25 Nm festziehen.
- Schrauben 23 beidseitig mit 25 Nm festziehen.

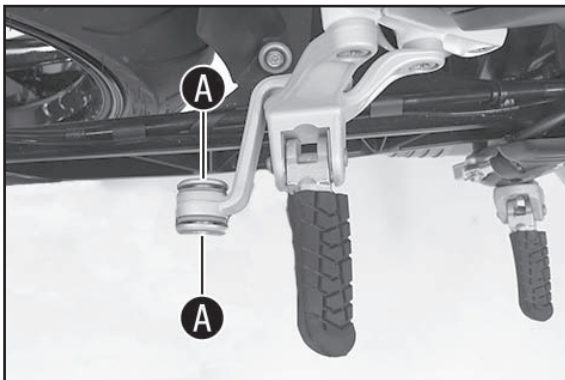

(nur Duke)

- Buchsen (Lieferumfang Montagekit A) auf Original-Dichtung montieren.

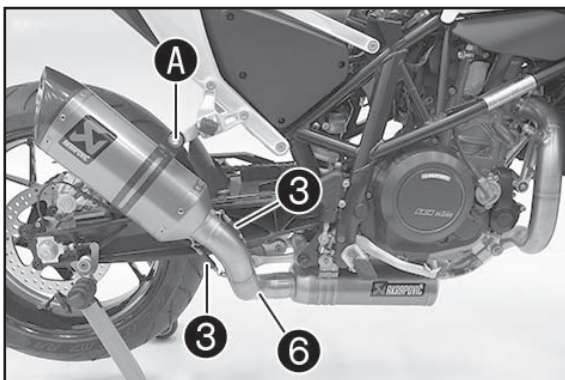

(Duke)

- Krümmerrohr 6 (Lieferumfang) auf Vorschalldämpfer montieren.
- Enddämpfer 1 (Lieferumfang) mit Auspuffschelle 2 (Lieferumfang) montieren.
- Schraube (Lieferumfang Montagekit A) mit Original-Scheibe und Mutter mit Scheibe (beides Lieferumfang Montagekit A) montieren und mit 15 Nm festziehen.
- Auspufffedern lang 3 (Lieferumfang) einhängen.

(Duke R)

- Krümmerrohr 6 (Lieferumfang) auf Vorschalldämpfer montieren.
- Original-Enddämpfer mit Auspuffschelle montieren.
- Original-Schraube 15 mit Scheibe montieren und mit 15 Nm festziehen.
- Auspufffedern lang 3 (Lieferumfang) einhängen.

(nur Duke)

- Auspufffeder kurz 7 (Lieferumfang) einhängen.

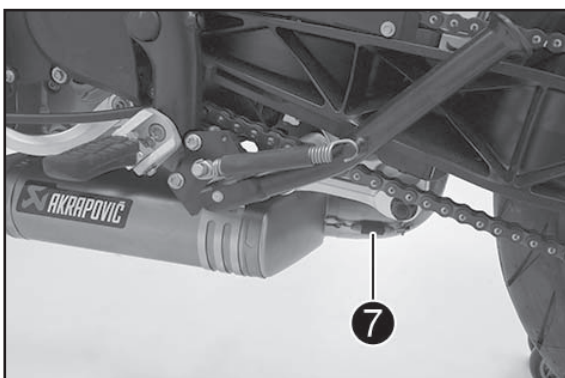

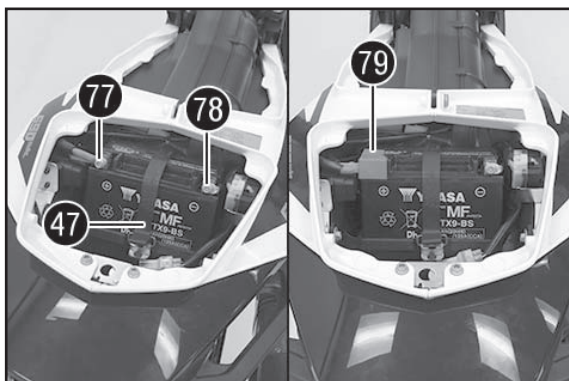

Batterie einbauen

- Batterie im Batteriehalter positionieren.
- ✓ Die Batteriepole zeigen entgegen der Fahrtrichtung.
- Haltegummi 47 einhängen.
- Beide Pluskabel 77 mit der Batterie verbinden und Schraube mit 2 Nm festziehen.
- Minuskabel 78 mit der Batterie verbinden und Schraube mit 2 Nm festziehen.
- Pluspolabdeckung 79 montieren.

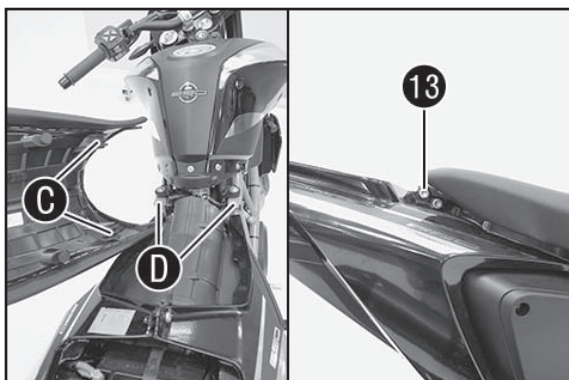

Fahrersitzbank montieren

- Sitzbank nach vorne schieben und hinten absenken.
- ✓ Die Nasen C greifen in die Laschen D des Rahmens ein.
- Schraube 13 montieren und mit 25 Nm festziehen.
- Abschließend kontrollieren, ob der Fahrersitz korrekt montiert ist.

Nacharbeit

- Beifahrersitzbank montieren (s. Bedienungsanleitung).
- Motorrad von Hebevorrichtung hinten nehmen (s. Bedienungsanleitung).



! VORSICHT

Beim erstmaligen Betrieb des Enddämpfers ist die Motordrehzahl für ca. 5 Minuten niedrig zu halten, um den Enddämpfer gleichmäßig zu erwärmen. Nur so kann der Dämmstoff seinen vollen Wirkungsgrad erreichen und die geforderte Lautstärke einhalten!

Endmontage

Stellen Sie sicher, dass die Auspuffanlage keine anderen Teile des Motorrads berührt.
 Fettrückstände mit einem weichen Tuch, besprüht mit Mehrzweckschmiermittel (Motorex Joker 440) entfernen.
 Das Reinigen verhindert, dass sich Flecken auf der Oberfläche einbrennen. Verwenden Sie keine aggressiven chemischen Reiniger, da sie den Aufkleber beschädigen können.
 Stellen Sie sicher, dass alle Schrauben angezogen sind. Falls die Auspuffanlage die Verkleidung oder andere Teile berührt, wiederholen Sie die Justierung oder kontaktieren Sie Ihren Vertragshändler!
 Es ist normal, wenn beim ersten Betrieb der Auspuffanlage weißer Rauch aus dem Schalldämpfer kommt!
 Abschließend gesamte Auspuffanlage auf Dichtheit prüfen.
 Stehen Sie beim ersten Betrieb nicht hinter dem Auspuff!

Wartung der Auspuffanlage

Reinigung mit einem Mehrzweckschmiermittelspray (Motorex Joker 440).
 Ein Wechsel der Farbe der Auspuffanlage ist aufgrund der hohen Temperatur normal.
 Die Abnutzung des Dämmmaterials des Schalldämpfers hängt von der Art des Motors und Fahrstils ab. Setzen Sie sich mit Ihrem Händler in Verbindung, wenn sichtbare Änderungen auf der Außenhülle des Schalldämpfers auftreten oder der Geräuschpegel erhöht ist. Überprüfen Sie periodisch, dass alle Schrauben genügend angezogen sind und die Federn auf korrekten Sitz.

Ersatzteile

- | | |
|---------------------------|-------------|
| Dämmstoffkit | 76005979010 |
| Dämmwolle | |
| 14x Niete D4,8x8 | |
| 2x Niete D4,8x12 | |
|
 | |
| Reparaturkit | 76005979220 |
| 1x Außenhülle Titan | |
| 2x Nietband Titan | |
| 14x Niete D4,8x8 | |
| 2x Niete D4,8x12 | |
| 1x Aufkleber | |
| 1x Aufkleber Patentnummer | |

- | | |
|---------------------------|-------------|
| 1x Auspuffschele Carbon ② | 76005979001 |
| 1x Endkappe Carbon ⑧⑩ | 76005979005 |
| 2x Auspufffeder lang ③ | 57305016000 |

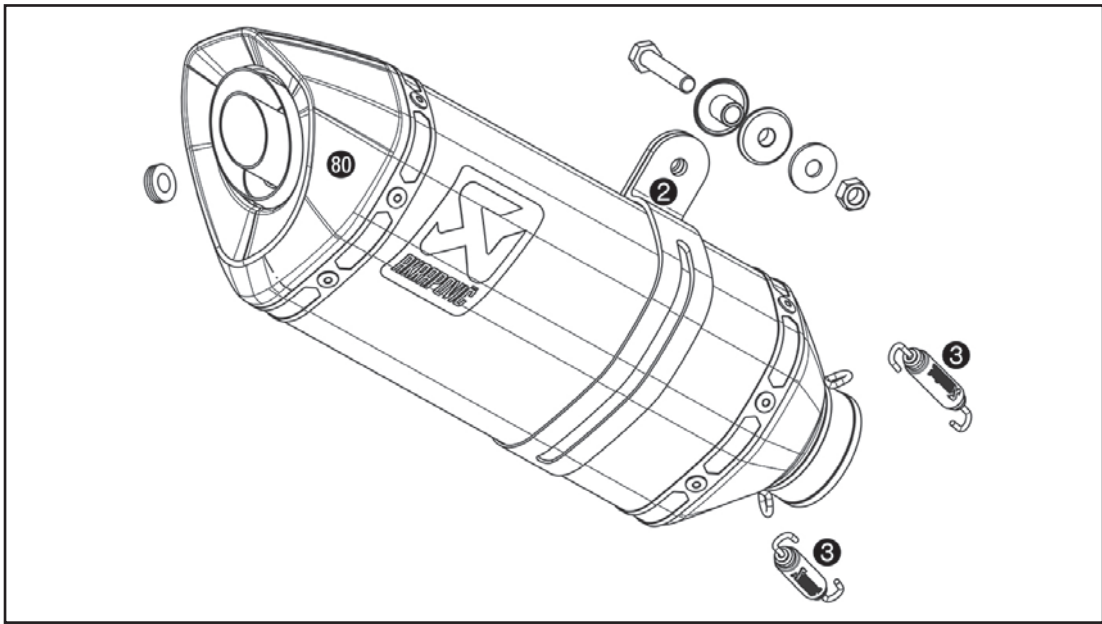

Ersatzteile

- | | |
|---------------------------|-------------|
| 1x Aufkleber Akrapovic ⑧③ | 60005099003 |
|---------------------------|-------------|

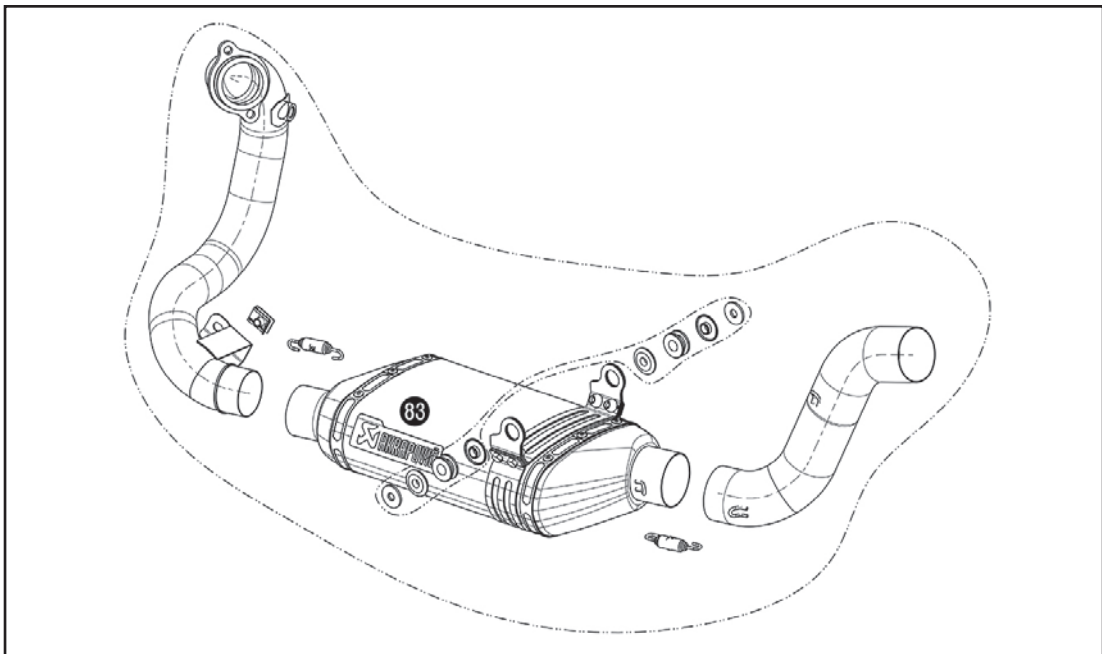

We advise you to have the tuning kit assembled by an authorized workshop or a qualified service technician. Incorrect assembly may result in a shorter service life and/or damage to the motorcycle!

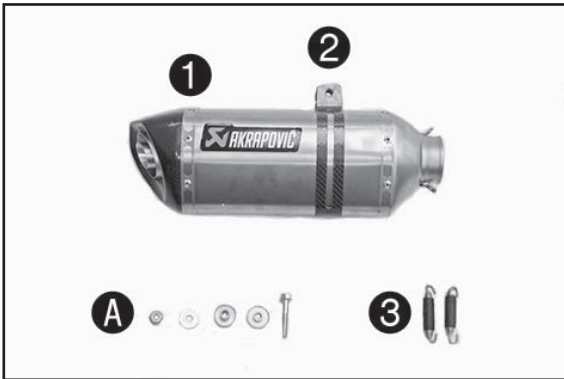

Scope of supply 76612945000 (690 Duke only)

- 1x AKRAPOVIC main silencer ① 76005979200
- 1x carbon exhaust clamp ②
- 2x exhaust springs, long ③
- 1x assembly kit ④

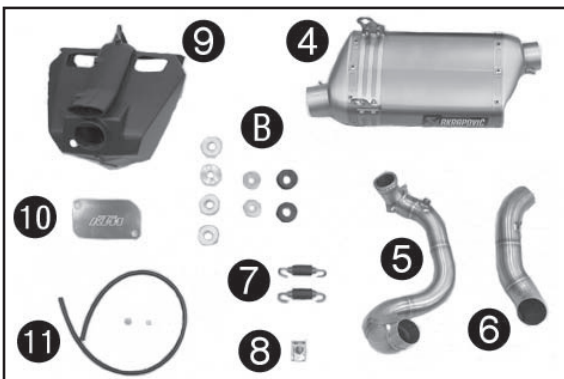

Scope of supply 76612945000 and 76612945100

- AKRAPOVIC EVO manifold set 76005907100
- 1x presilencer ④
- 1x manifold ⑤
- 1x header pipe ⑥
- 2x exhaust springs, short ⑦
- 1x speed nut ⑧
- 1x assembly kit ④
- 1x tuning air filter box ⑨ 76006901000
- 1x SAS locking cap ⑩ 60005022200
- 1x EVAP disassembly kit ⑪ 76015999044



⚠ WARNING

This tuning kit has not been granted homologation!

The unit may only be installed and operated in combination with the special AKRAPOVIC EFI mapping. The mapping must be installed by your authorized dealer before initial operation!

- AKRAPOVIC EFI Mapping (690 Duke) 76641033131
- AKRAPOVIC EFI Mapping (690 Duke R) 76641033132

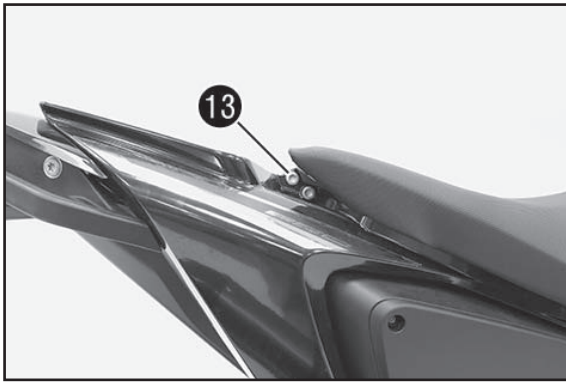

Preparatory work

- Raise the rear of the motorcycle using lifting gear (see Owner's Manual).
- Take off the passenger seat (see the Owner's Manual).
- Disconnect the battery (see Owner's Manual).

Taking off the front rider's seat

- Remove screw 13.
- Lift up the seat at the rear, pull it back, and lift off.

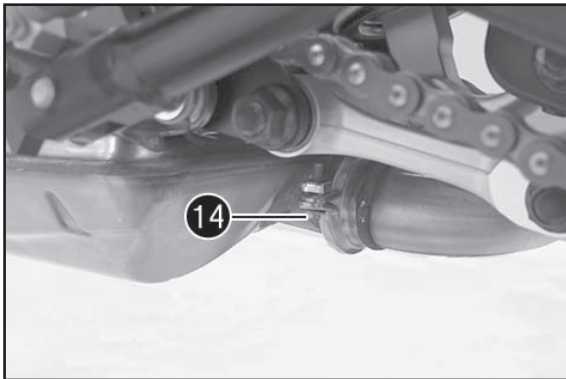

Removing the main silencer

Warning
Danger of burns

The exhaust system gets very hot when the vehicle is driven.
- Let the exhaust system cool down. Do not touch hot parts.

- Remove screw 14. Take off the clamp of the main silencer.

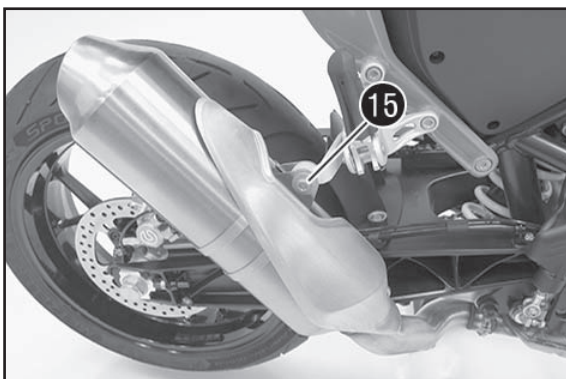

(Duke)

- Remove screw 15 with the washer.
- Take off the main silencer.

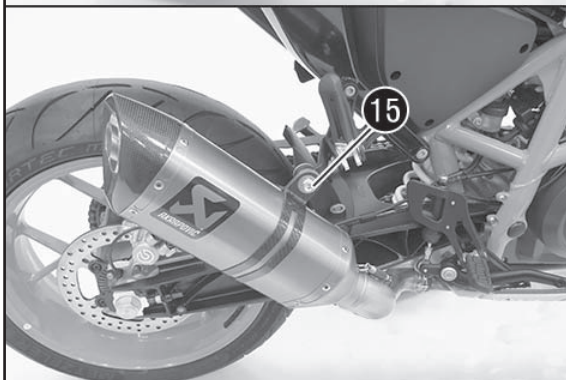

(Duke R)

- Remove screw 15 with the washer.
- Take off the main silencer.



Removing the exhaust system

- Remove screw 16 on both sides. Remove left and right trim.
- Remove cable ties 17. Disconnect plug-in connector 18 of the lambda sensor.

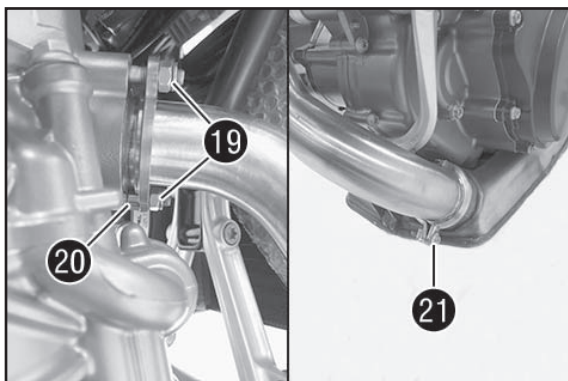

- Remove nuts 19.

NOTE

Do not misplace spacer 20.

- Remove screw 21. Take off the clamp.
- Remove the manifold and gasket.

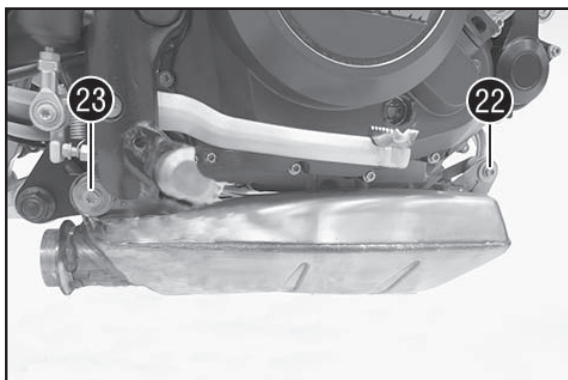

- Remove screw 22 with the washer.
- Remove screws 23 on both sides.
- Take off the presilencer.

Removing the fuel tank



Danger

Fire hazard Fuel is highly flammable.

- Never refuel the vehicle near open flames or burning cigarettes, and always switch off the engine first. Be careful that no fuel is spilled, especially on hot vehicle components. Wipe up any spilled fuel immediately.
- The fuel in the fuel tank expands when warm and may emerge if overfilled. Note the information on filling the fuel tank.



Warning

Danger of poisoning Fuel is toxic and poses a risk to your health

- Fuel must not come into contact with the skin, eyes, or clothing. Do not breathe in the fuel vapors. If contact occurs with the eyes, rinse with water immediately and contact a physician. Immediately clean contaminated areas on the skin with soap and water. If fuel is swallowed, contact a physician immediately. Change clothing that has been contaminated with fuel. Store fuel properly in a suitable canister and keep away from children.

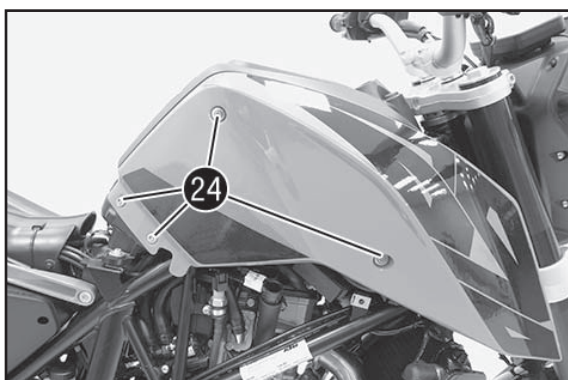

- Remove screws 24.
- Take off the right spoiler.

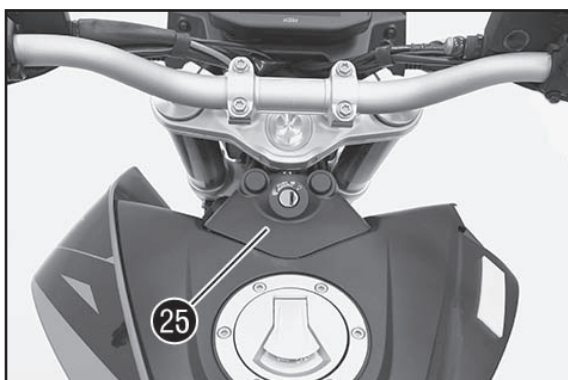

- Pull trim 25 upward and take off.

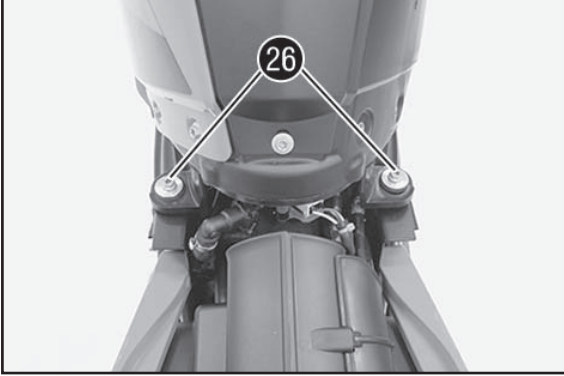
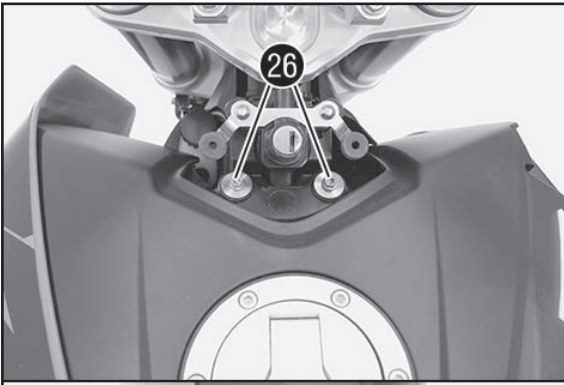

- Remove screws 26.

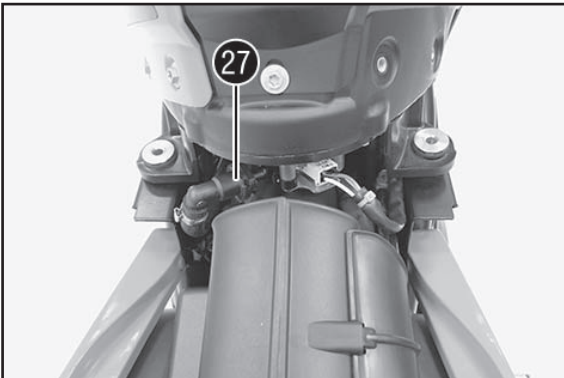

- Disconnect fuel hose connection 27.

NOTE

Remaining fuel may flow out of the fuel hose.

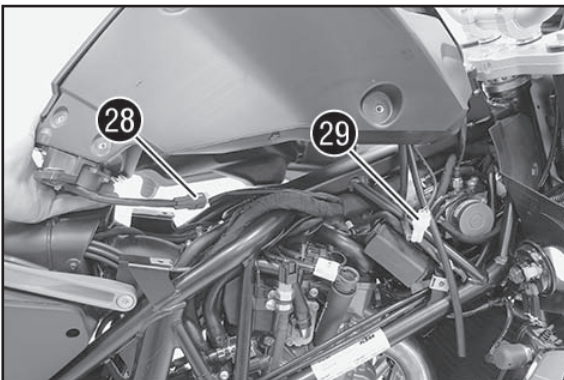

- Raise the fuel tank.

- Disconnect plug-in connector 28.

- Disconnect plug-in connector 29.

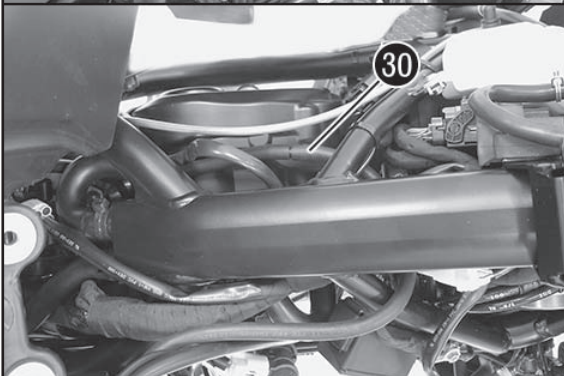

(Duke)

- Pull off vent hose 30.

- Take off the fuel tank.

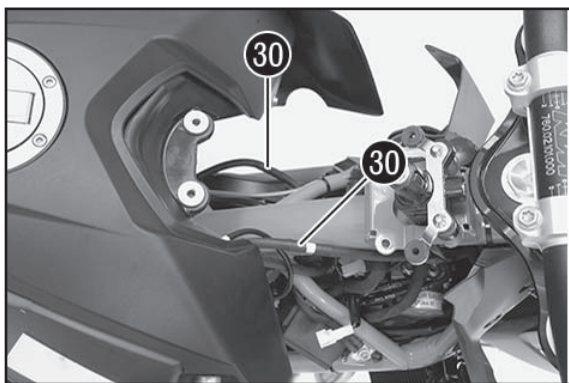

(Duke R)

- Pull off vent hoses 30.
- Take off the fuel tank.

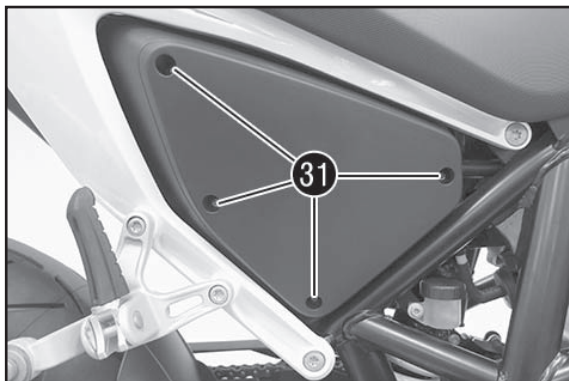

Removing the air filter box

- Remove screws 31.
- Take off the air filter box lid.

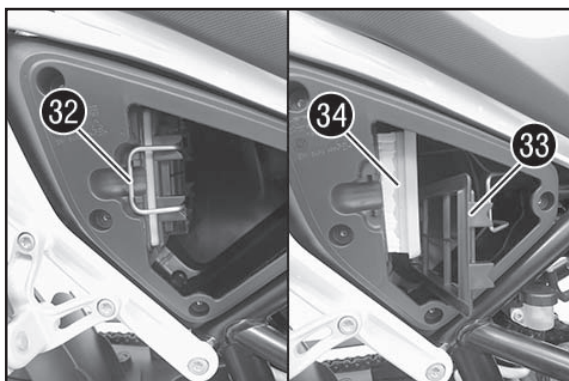

- Detach air filter holder 32 and move aside.
- Remove filter frame 33 and air filter 34.

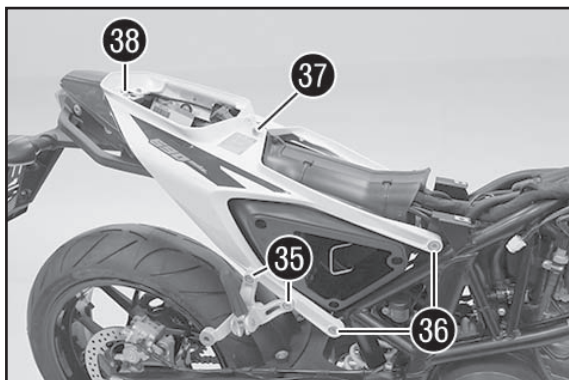

- Remove screws 35.
- Take off the passenger footrest bracket.
- Remove screws 36.
- Remove screw 37.
- Remove screw 38.

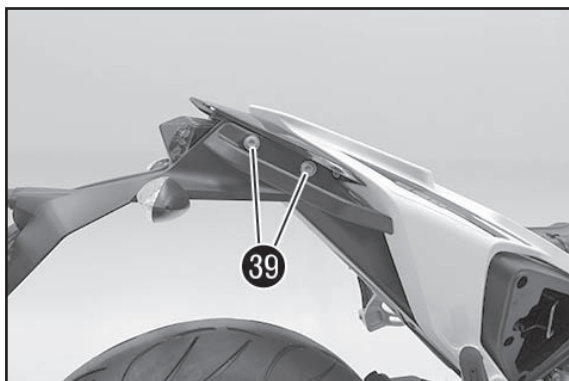

- Remove screws 39 on both sides.
- Remove the grab handle.

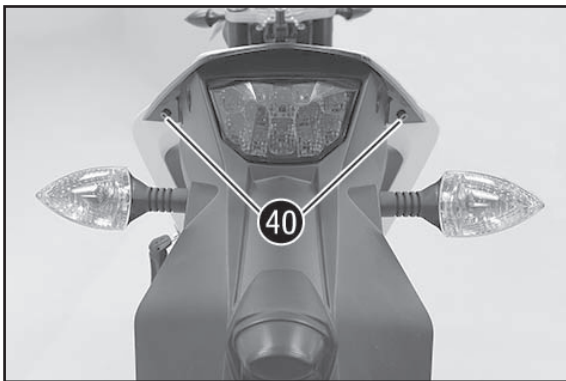

- Remove screws 40.
- Take off the rear cover.

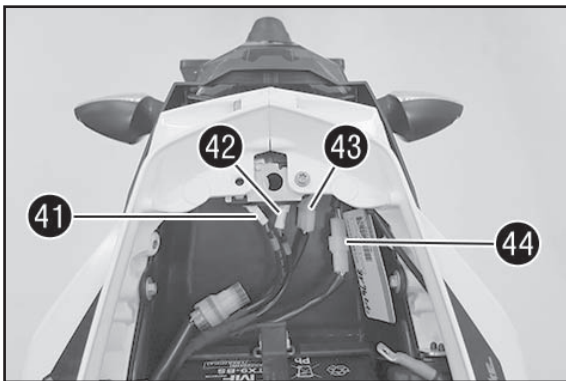

- Disconnect plug-in connector 41.
- Disconnect plug-in connector 42.
- Disconnect plug-in connector 43.
- Disconnect plug-in connector 44.
- Slip out the cables and take off the license plate holder.

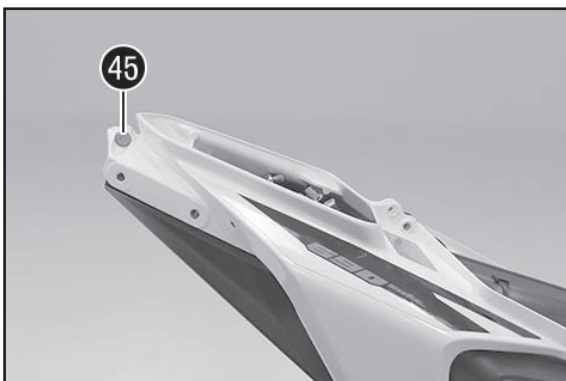

- Remove screw 45.

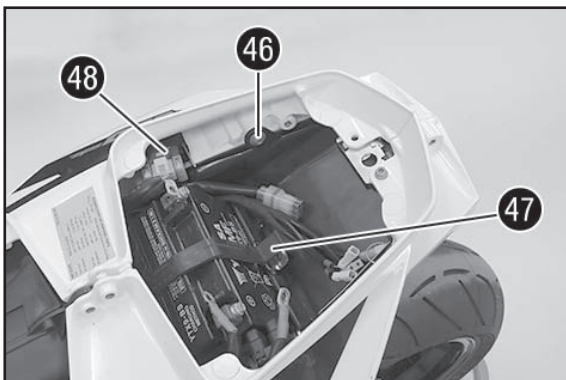

- Remove screw 46.
- Detach rubber strap 47.
- Pull the battery up and out of the battery holder.
- Pull off starter relay 48 from the retaining bracket.

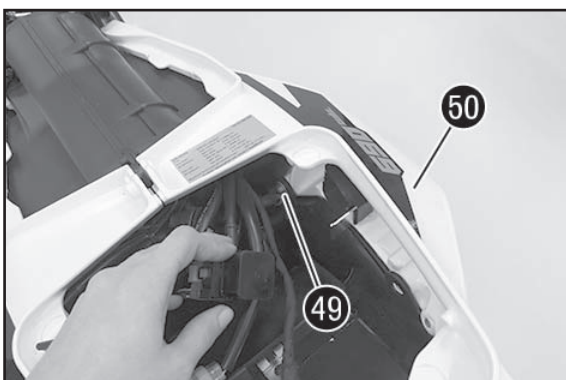

- Remove screw 49.
- Remove right tail section 50.

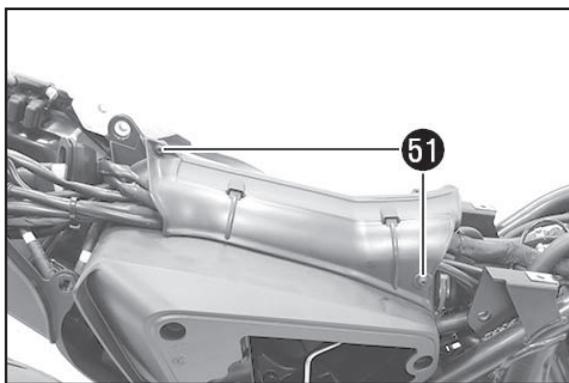

- Remove screws 51.
- Remove the right cable cover.

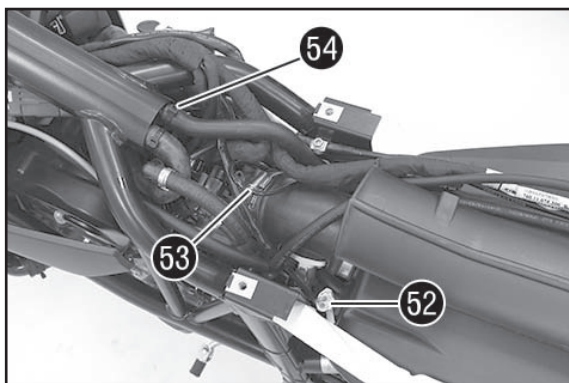

- Disconnect plug-in connector 52.
- Loosen hose clip 53.
- Remove cable tie 54.
- Pull off the vent hose.

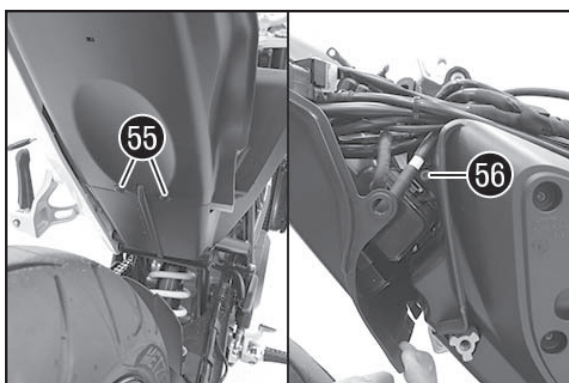

- Remove plugs 55.
- Remove screw 56.

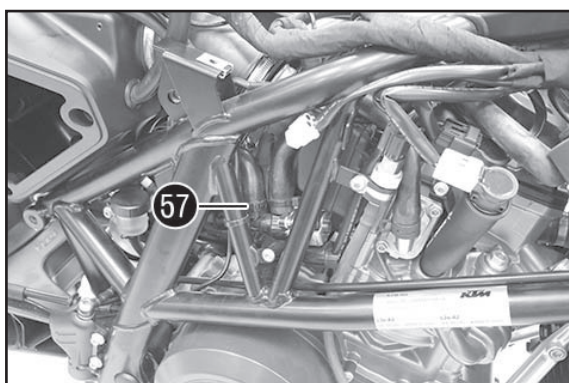

- Remove cable tie 57.
- Pull off the SAS hose.

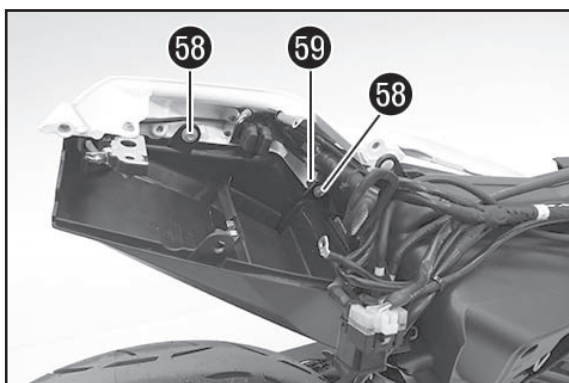

- Remove screws 58.
- Remove seat lock cable holder 59.
- Take off the battery holder.

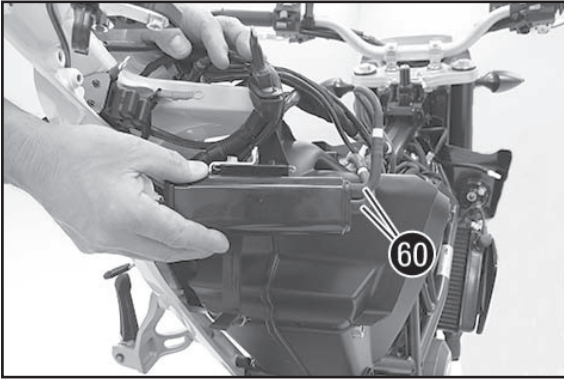

- Pull off hoses 60.
- Remove the activated charcoal filter.

NOTE

The activated charcoal filter will not be refitted.

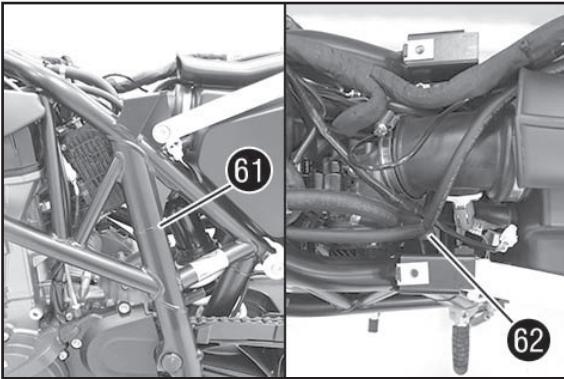

- Remove cable tie 61.
- Remove Y-piece 62 with the hoses.

NOTE

The hoses will not be reinstalled.

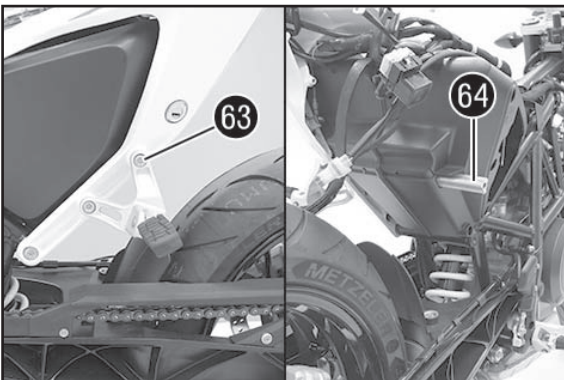

- Remove screw 63.
- Remove sleeve 64 to the right.



- Remove the air filter box.

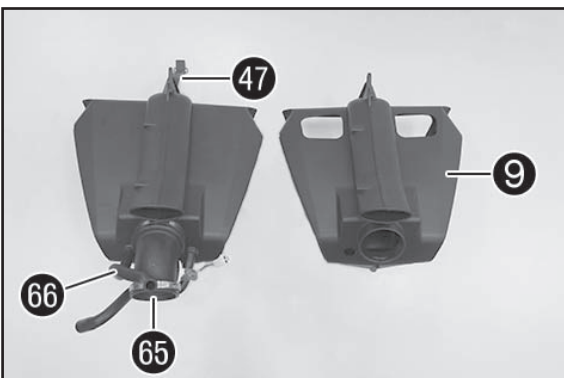

Air filter box preassembly

- Remount rubber strap 47, intake trumpet 65 with hose clip, and vent hose 66 from the original air filter box on to air filter box 9 (included).

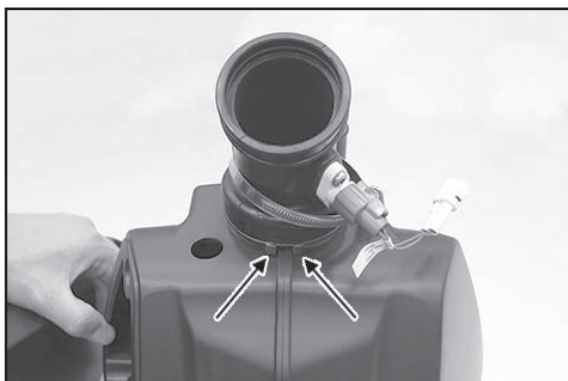

NOTE
Mount the intake trumpet as shown.

✓ Holding lugs position the intake trumpet on the bar (see arrow).

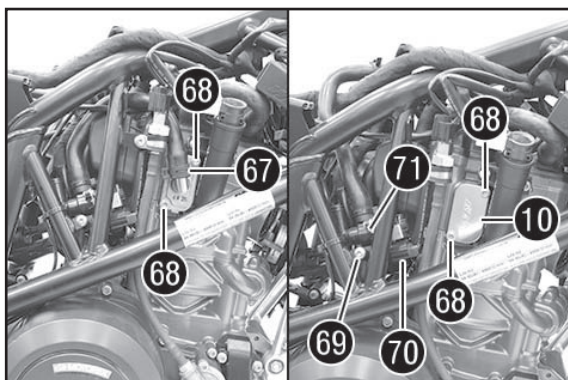

SAS disassembly

- Loosen spring band clamp 67 and pull off the SAS hose.
- Remove screws 68.
- Remove the cover.
- Position SAS cover 10 (included).
- Mount original screws 68 and tighten to 10 Nm.
- Remove screw 69.
- Unplug connector 70, route the cable without tension and secure using cable tie(s) on to the wiring harness.
- Remove SAS valve 71 with the hose.

NOTE
The SAS valve is not refitted.

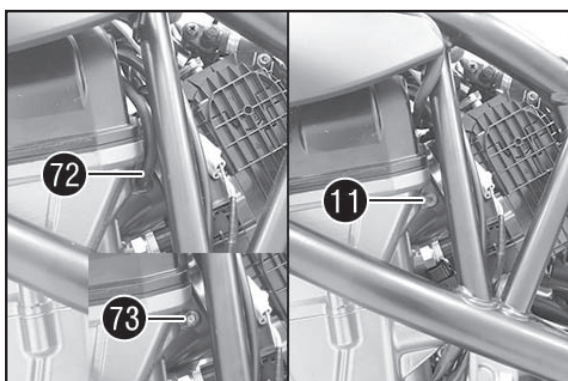

EVAP disassembly kit

- Pull off hose 72 on the left-hand side.
- Remove valve 73.

NOTE
The hose and valve are not refitted.

- Mount the screw with seal ring 11 (both included) and tighten to 10 Nm (Loctite 243).

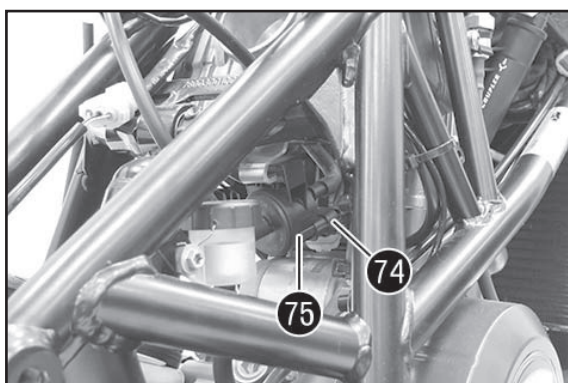

- Unplug connector 74, route the cable without tension and secure using cable tie(s) on to the wiring harness.
- Pull the EVAP valve 75 off of the retaining bracket and remove with the hoses.

NOTE
The EVAP valve is not refitted.

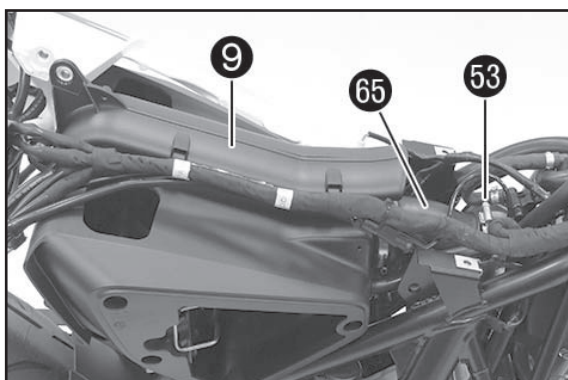

Installing the air filter box

- Position air filter box 9 (included).
- Mount intake trumpet 65.
- Position hose clip 53 and tighten.

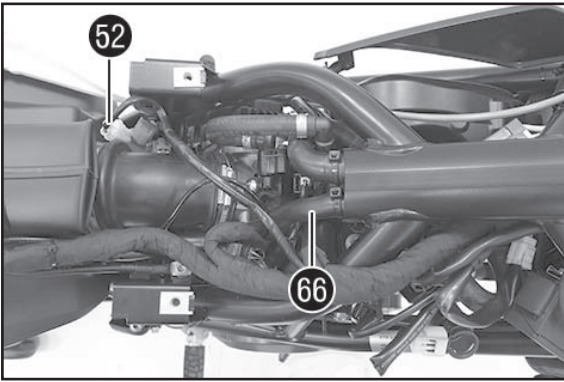

- Join plug-in connector 52.
- Mount vent hose 66 and secure with cable tie(s).



- Mount original sleeve 64.
- Mount original screw 63 but do not tighten yet.

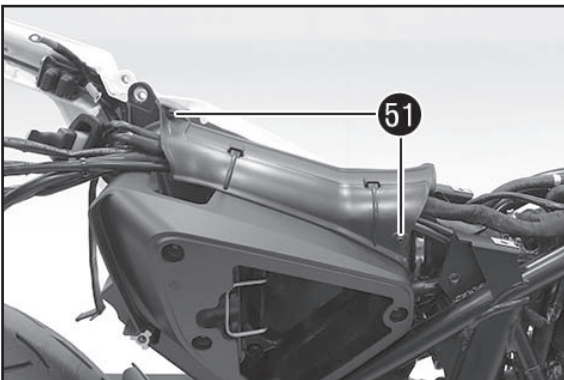

- Position the cable cover on the right-hand side.
- Mount and tighten original screws 51.

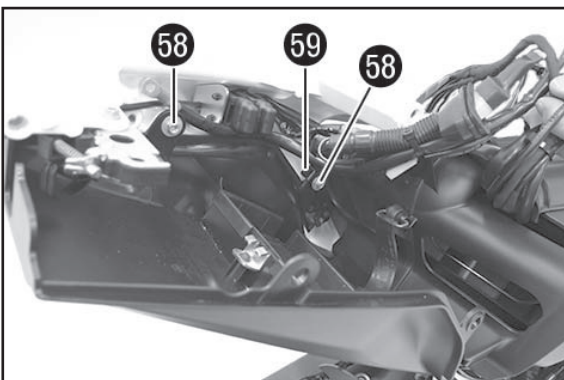

- Position the battery holder.
 - Position seat lock cable holder 59 and attach the cable.
- NOTE
The cable holder is positioned at the front.
- Mount original screws 58 and tighten to 10 Nm.



- Mount original plugs 55.

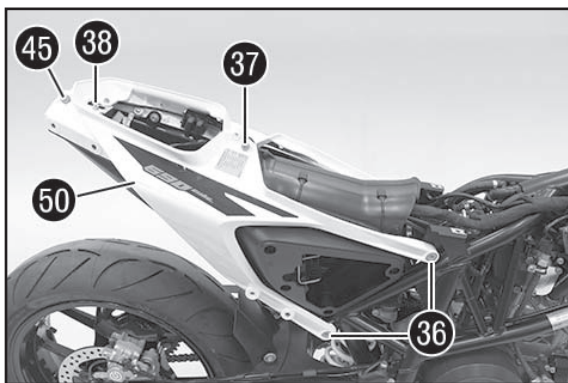

- Position right tail section 50.
- Mount original screws 36, 37, and 38, but do not tighten yet.
- Mount original screw 45 and tighten to 25 Nm (Loctite 243).
- Tighten screws 36 to 45 Nm.
- Tighten screw 37 to 25 Nm (Loctite 243).
- Tighten screw 38 to 10 Nm (Loctite 243).

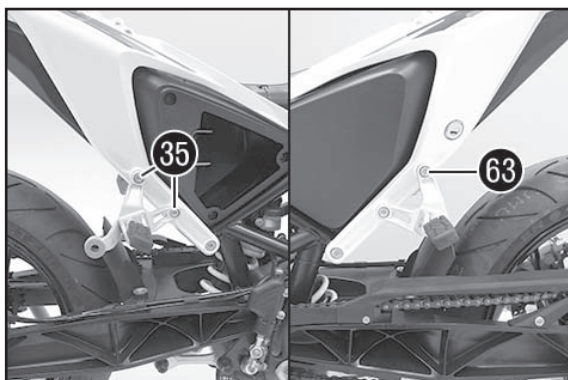

- Position the passenger footrest bracket.
- Mount original screws 35 and tighten to 25 Nm (Loctite 243).
- Mount original screw 63 and tighten to 25 Nm (Loctite 243).

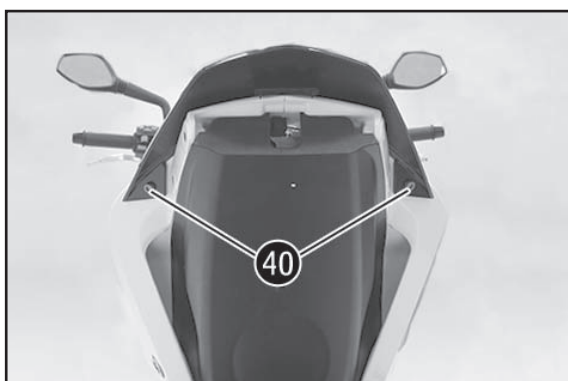

- Position the rear cover.
- Mount original screws 40 and tighten to 10 Nm.

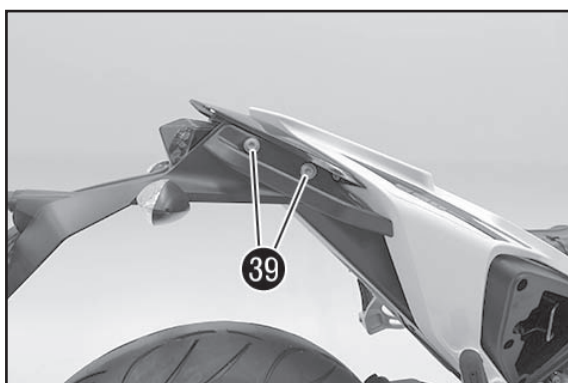

- Thread in the cables and position the license plate holder.
- Position the grab handle.
- Mount original screws 39 and tighten to 18 Nm (Loctite 243).

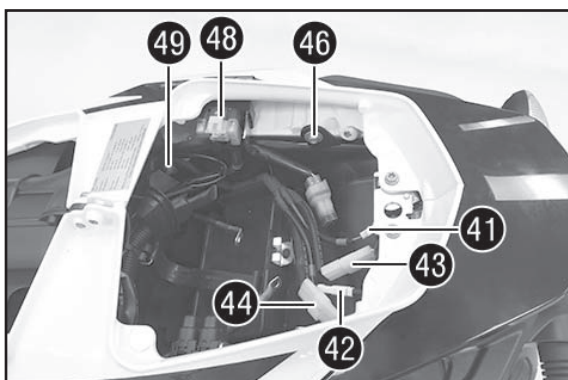

- Join plug-in connector 41.
- Join plug-in connector 42.
- Join plug-in connector 43.
- Join plug-in connector 44.
- Mount original screw 46 and tighten to 10 Nm.
- Mount original screw 49 and tighten to 10 Nm.
- Mount starter relay 48 on the retaining bracket.

! ATTENTION

Route all cables properly and secure with cable ties if necessary. Ensure that the cables are not kinked or pinched!

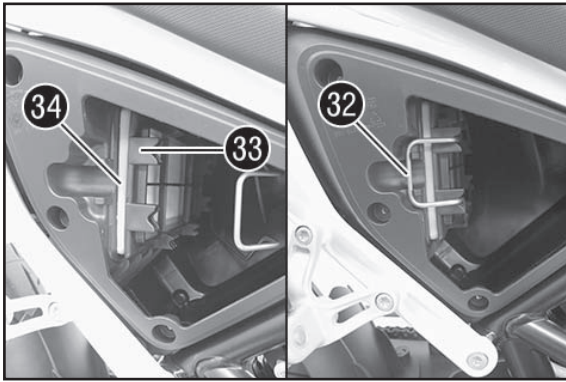

- Position air filter 34 and filter frame 33.
- Position air filter holder 32 and attach.

NOTE

The holding bracket must lie in the recesses of the filter frame on all sides.

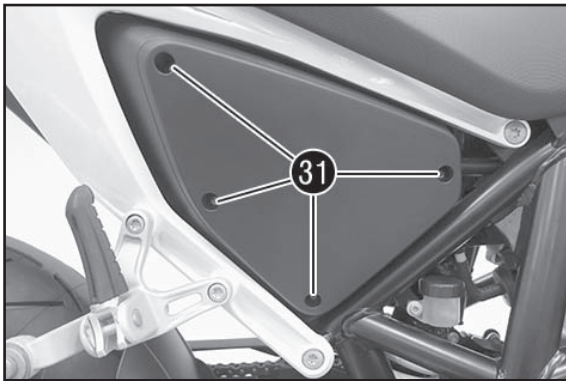

- Mount the air filter box lid.
- Mount original screws 31 and tighten to 3 Nm.

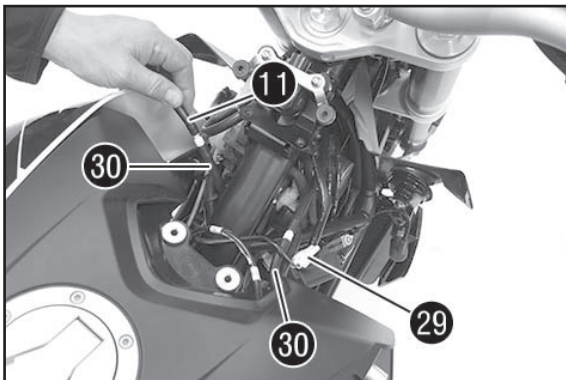

Installing the fuel tank

- Raise the fuel tank.
- Join plug-in connector 29.
- Mount vent hose 30.
- Thread vent hose 30 through to the other side.
- Mount vent hose 11 (included).

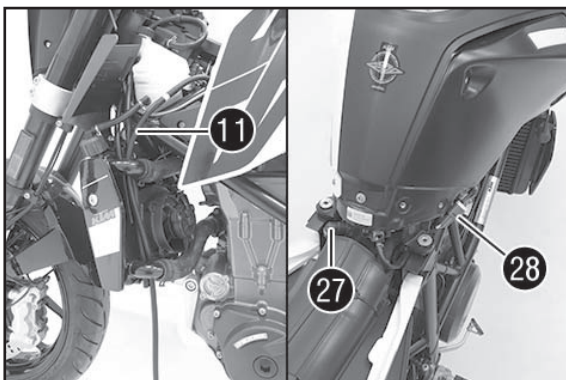

- Route vent hose 11 downwards without tension.
- NOTE**
The hose must be shortened if it is too long.

- Position the fuel tank.
- Join fuel hose connection 27 with a new O-ring.
- Join plug-in connector 28.



- Mount original screws 26 and tighten to 10 Nm.

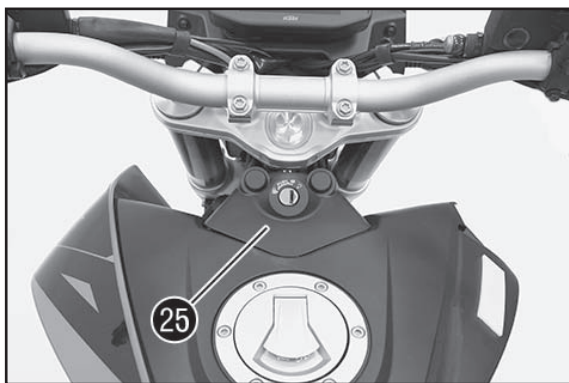

- Mount trim 25.

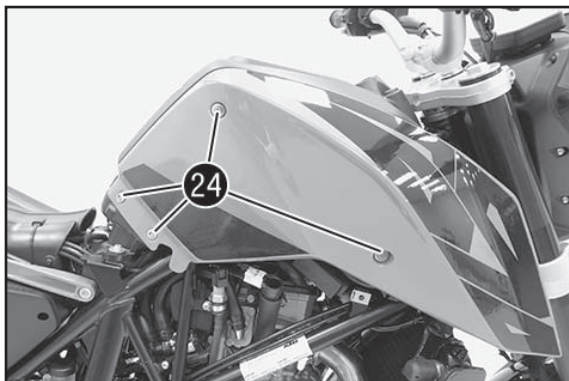

- Position the spoiler.
- Mount original screws 24 and tighten to 3 Nm.

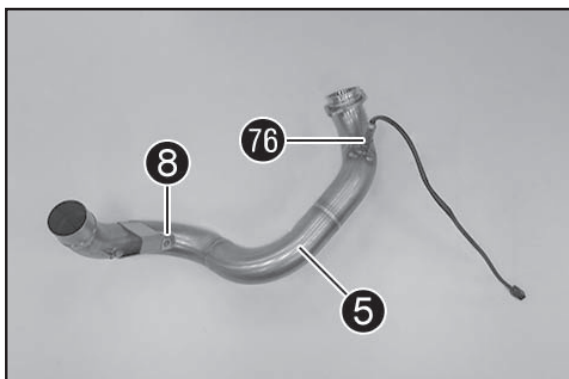

Manifold preassembly

- Remount lambda sensor 76 from original manifold to manifold 5 (included).
- Mount range change metal nut 8 (included).

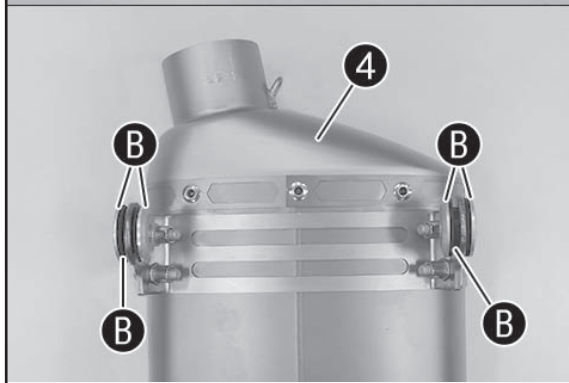

- Mount rubber bushing (included in assembly kit B) to presilencer holder 4 (included).
- Mount silver bushings (included in assembly kit B) on to the rubber bushings on the left and right.

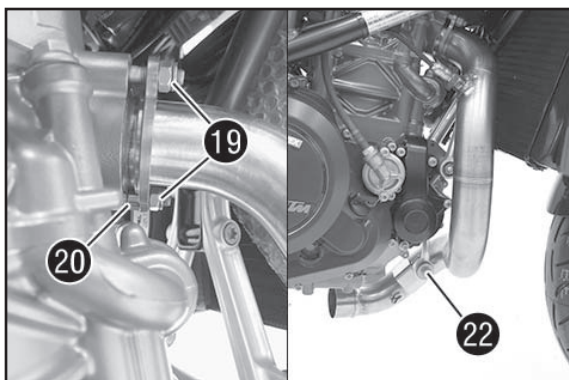

Installing the exhaust system

- Position manifold 5 (included) with the gasket.
- Mount original nuts 19 with spacer 20 but do not tighten yet.
- Mount original screw 22 with the washer but do not tighten yet.

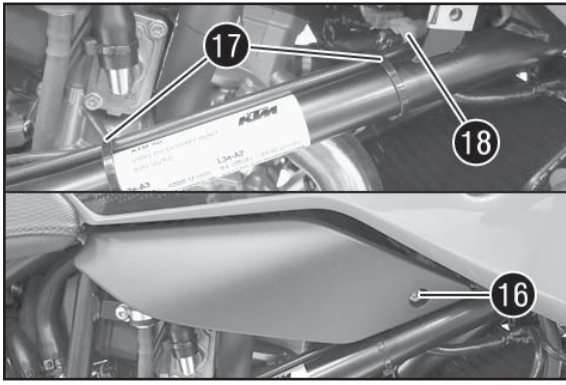

- Join plug-in connector **18** of the lambda sensor. Secure the cable with cable ties **17**.
- Mount the left and right trim.
- Mount original screws **16** on both sides and tighten to 3 Nm.

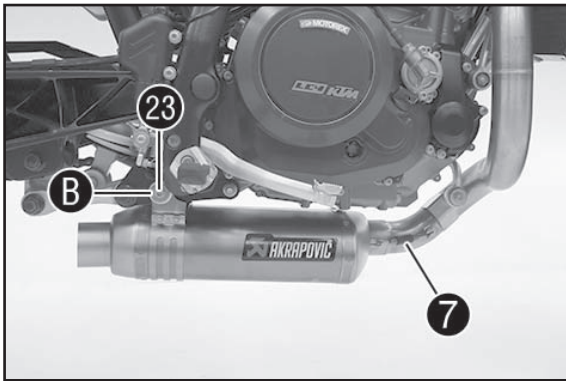

- Position presilencer **4** (included).
- Mount original screws **23** with washers (included in assembly kit **B**) on both sides, but do not tighten yet.
- Mount the short exhaust spring **7** (included).
- Tighten nuts **19** evenly to 20 Nm (copper paste).
- Tighten screw **22** to 25 Nm.
- Tighten screws **23** to 25 Nm on both sides.

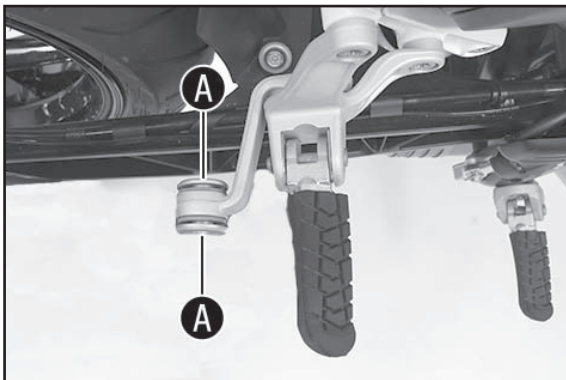

(Duke only)

- Mount bushings (included in assembly kit **A**) to original seal.

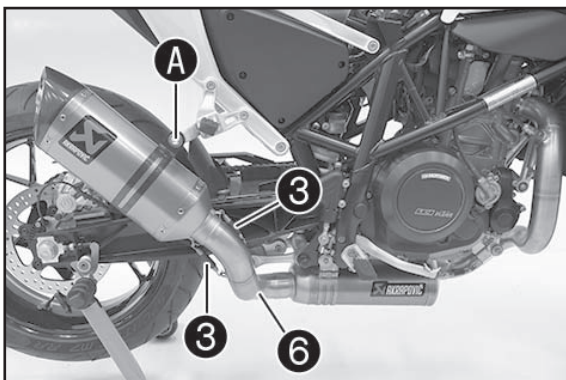

(Duke)

- Mount header pipe **6** (included) to presilencer.
- Mount main silencer **1** (included) with exhaust clamp **2** (included).
- Mount screw (included in assembly kit **A**) with original washer, and nut with washer (both included in assembly kit **A**) and tighten to 15 Nm.
- Attach exhaust springs **3** (included).

(Duke R)

- Mount header pipe **6** (included) to presilencer.
- Mount the original main silencer with the exhaust clamp.
- Mount original screw **15** with the washer and tighten to 15 Nm.
- Attach exhaust springs **3** (included).

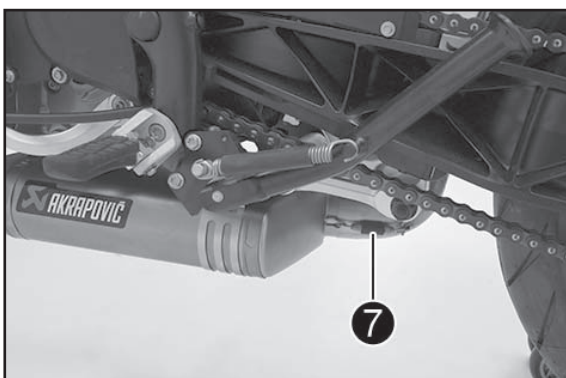

(Duke only)

- Attach short exhaust spring **7** (included).

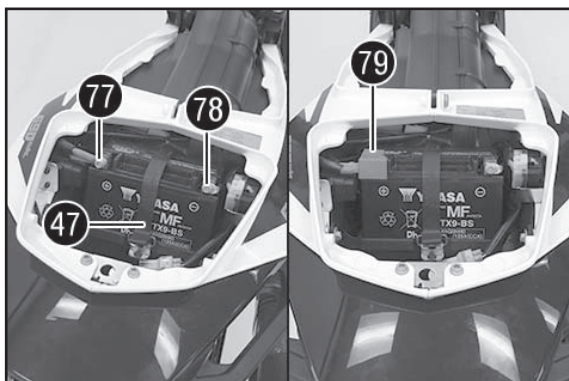

Installing the battery

- Position the battery in the battery holder.
- ✓ The battery terminals face opposite the direction of travel.
- Attach rubber strap 47.
- Connect both positive cables 77 to the battery and tighten the screw to 2 Nm.
- Connect negative cable 78 to the battery and tighten the screw to 2 Nm.
- Mount positive terminal cover 79.

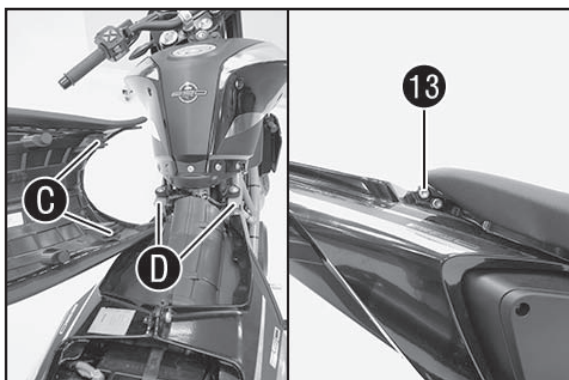

Mounting the front rider's seat

- Push the seat forward and lower at the rear.
- ✓ Catches C engage in loops D on the frame.
- Mount screw 13 and tighten to 25 Nm.
- Finally, check that the front rider's seat is correctly mounted.

Final steps

- Install the passenger seat (see the Owner's Manual).
- Remove the rear of the motorcycle from the lifting gear (see the Owner's Manual).



! ATTENTION

When you first use the main silencer, keep the engine speed low for about 5 minutes to warm the main silencer evenly. This will ensure that the rock wool will have full effect and keep noise down to the required level!

Final steps

Make sure that the exhaust system is not touching any other parts of the motorcycle.
 Remove all grease residue with a soft cloth sprayed with multi-purpose lubricant (Motorex Joker 440).
 Cleaning prevents stains from baking onto the surface. Do not use aggressive chemical cleaners as they may damage the sticker.
 Make sure that all screws are tightened. If the exhaust system is touching the trim or other parts, readjust the unit or contact your authorized dealer.
 When the exhaust system is first put into operation, it is normal for white smoke to be emitted by the silencer.
 Finally, check for leaks in the whole exhaust system.
 Do not stand behind the exhaust when it is being used for the first time.

Maintaining the exhaust system

Clean with a multi-purpose lubrication spray (Motorex Joker 440).
 A change in color of the exhaust system is normal due to the high temperatures.
 Wear and tear to the rock wool of the silencer depends on the type of engine and driving style. Contact your dealer in the event of visible changes to the outer sleeve of the silencer or if the noise level is raised. Periodically check that all screws are tightened sufficiently and that the springs are seated correctly.

Spare parts

Rock wool kit 76005979010
Damping wool
14x rivet D4.8x8
2x rivets D4.8x12

Repair kit 76005979220
1x titanium outer sleeve
2x titanium rivet bands
14x rivets D4.8x8
2x rivets D4.8x12
1x sticker
1x sticker with patent number

1x carbon exhaust clamp ② 76005979001
1x carbon silencer cap ⑧⑩ 76005979005
2x exhaust springs, long ③ 57305016000

» ENGLISH

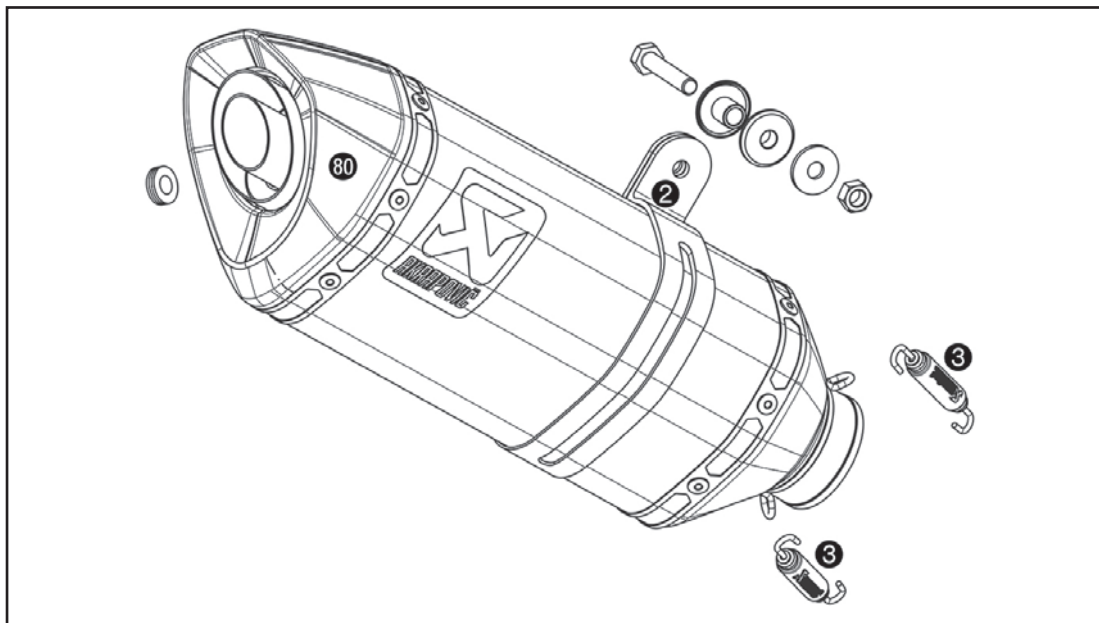

Spare parts

1x Akrapovic sticker ⑧③ 60005099003

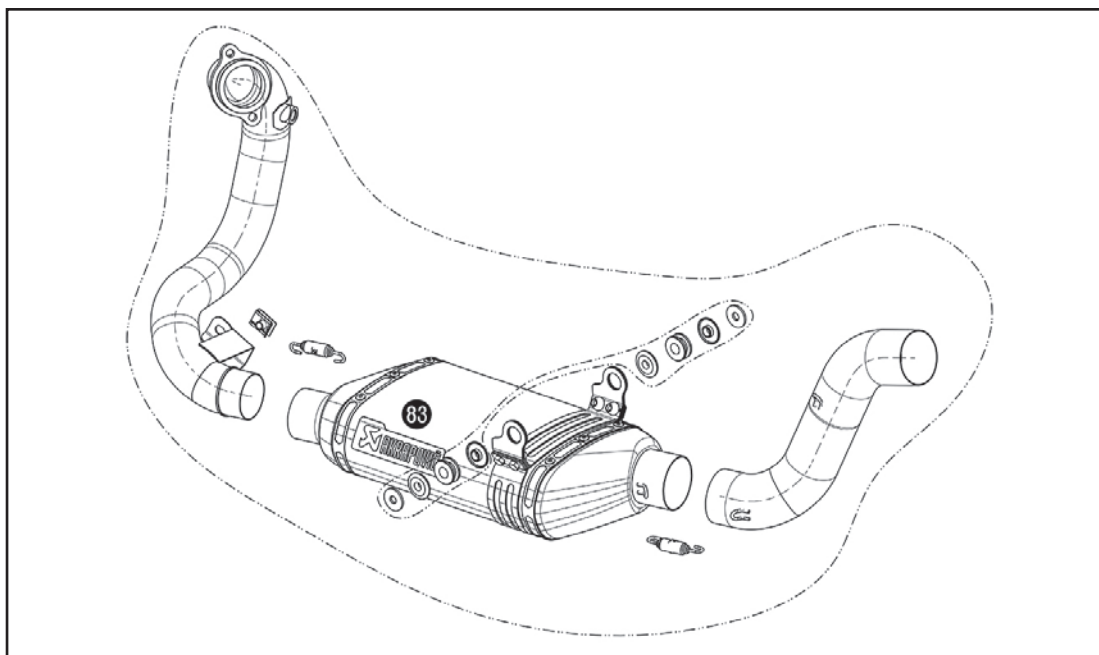

Consigliamo di far eseguire il montaggio del kit di messa a punto esclusivamente da un'officina autorizzata o da un tecnico qualificato dell'assistenza! Un montaggio improprio può ridurre la vita utile e/o provocare danni alla motocicletta!

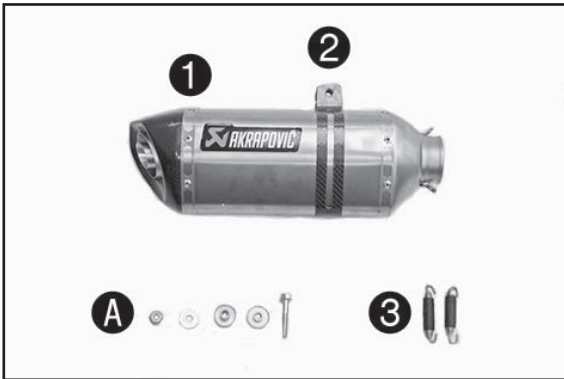

Volume della fornitura 76612945000 (solo 690 Duke)

- N. 1 silenziatore AKRAPOVIC ① 76005979200
- N. 1 collare dello scarico in carbonio ②
- N. 2 molle lunghe dell'impianto di scarico ③
- N. 1 kit di montaggio ④

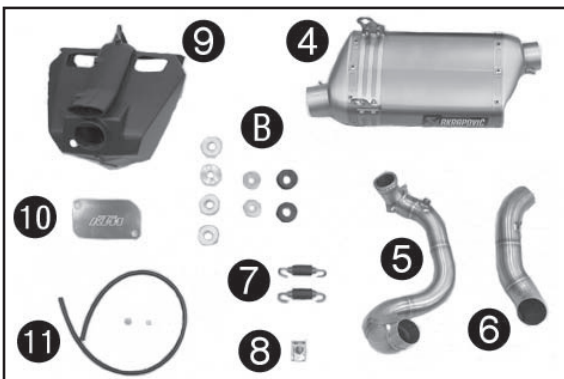

Volume della fornitura 76612945000 e 76612945100

- Set collettore AKRAPOVIC EVO 76005907100
- N. 1 presilenziatore ④
 - N. 1 collettore ⑤
 - N. 1 curva ⑥
 - N. 2 molle corte dell'impianto di scarico ⑦
 - N. 1 dado per lamiera ⑧
 - N. 1 kit di montaggio ⑨
- N. 1 cassa filtro per tuning ⑩ 76006901000
 - N. 1 coperchio di chiusura dell'impianto aria secondaria ⑪ 60005022200
 - N. 1 kit di smontaggio EVAP ⑫ 76015999044



⚠ ATTENZIONE

Questo kit di messa a punto non è omologato per l'impiego su strada!

L'impianto può essere utilizzato e montato soltanto in abbinamento alla speciale mappatura EFI AKRAPOVIC. La mappatura deve essere tassativamente installata dal proprio rivenditore prima dell'utilizzo iniziale!

- Mappatura EFI AKRAPOVIC (690 Duke) 76641033131
- Mappatura EFI AKRAPOVIC (690 Duke R) 76641033132

» ITALIANO

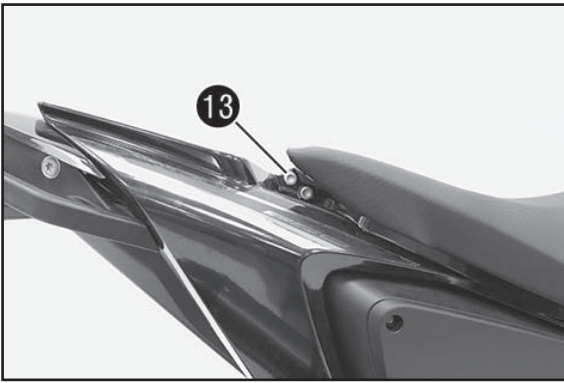

Operazione preliminare

- Sollevare la motocicletta tramite il cavalletto alzamoto posteriore (v. manuale d'uso).
- Rimuovere la sella del passeggero (v. manuale d'uso).
- Scollegare la batteria (v. manuale d'uso).

Smontaggio della sella del conducente

- Rimuovere la vite 13.
- Sollevare la parte posteriore della sella, tirarla indietro ed estrarla verso l'alto.

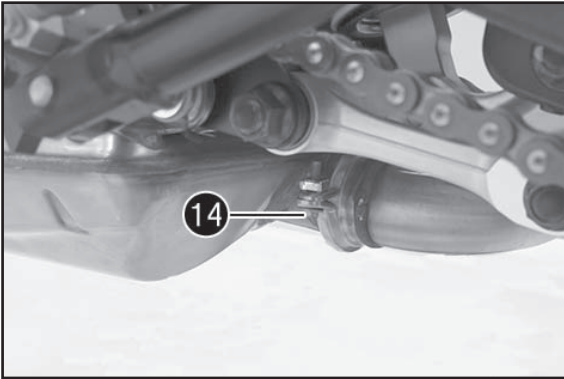

Smontaggio del silenziatore

⚠ Avvertenza
Pericolo di ustione

Durante il funzionamento, l'impianto di scarico del veicolo raggiunge temperature molto alte.

- Far raffreddare l'impianto di scarico. Non toccare i componenti che scottano.
- Rimuovere la vite 14. Rimuovere la fascetta del silenziatore.

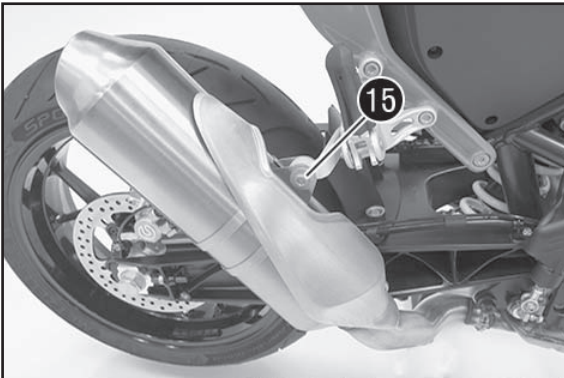

(Duke)

- Rimuovere la vite 15 con la rondella.
- Rimuovere il silenziatore.

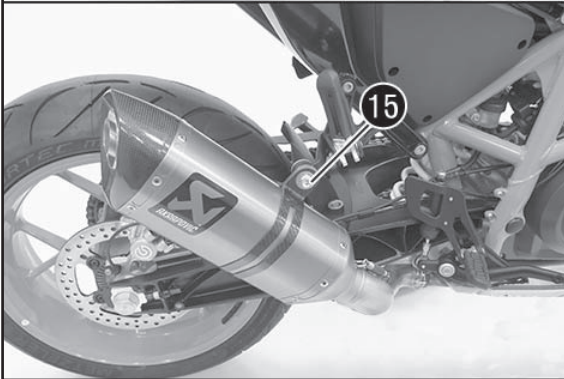

(Duke R)

- Rimuovere la vite 15 con la rondella.
- Rimuovere il silenziatore.

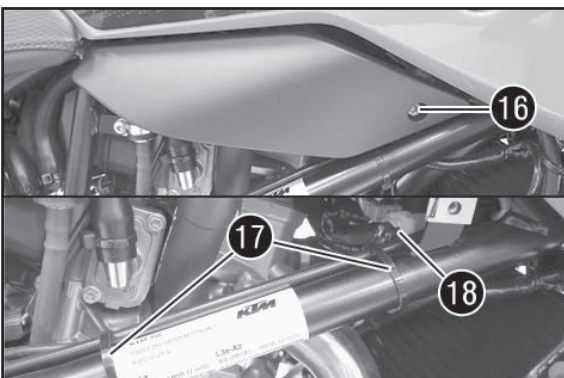

Smontaggio dell'impianto di scarico

- Rimuovere la vite 16 da entrambi i lati. Rimuovere il rivestimento destro e sinistro.
- Rimuovere le fascette serracavi 17. Scollegare il connettore 18 della sonda lambda.

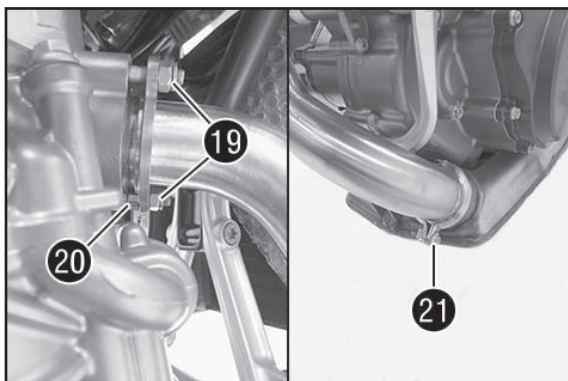

- Rimuovere i dadi 19.

AVVERTENZA

Prestare attenzione a non perdere la bussola distanziale 20.

- Rimuovere la vite 21. Rimuovere la fascetta.
- Rimuovere il collettore e la guarnizione.



- Rimuovere la vite 22 con la rondella.
- Rimuovere le viti 23 da entrambi i lati.
- Rimuovere il presilenziatore.

Smontaggio del serbatoio



Pericolo

Pericolo d'incendio Il carburante è facilmente infiammabile

- Non effettuare il rifornimento del veicolo in prossimità di fiamme libere o sigarette accese e spegnere sempre il motore. In particolare, prestare attenzione affinché il carburante non venga a contatto con parti calde del veicolo. Pulire immediatamente eventuali tracce di carburante traboccato.
 - All'interno del serbatoio il carburante tende a espandersi e, in caso di riscaldamento, potrebbe fuoriuscire se il livello di riempimento è eccessivo.
- Al momento di effettuare il rifornimento, attenersi alle indicazioni.



Avvertenza

Rischio di avvelenamento Il carburante è un liquido tossico e dannoso per la salute

- Evitare che il carburante venga a contatto con la pelle, gli occhi e gli abiti. Non respirare i vapori di carburante. In caso di contatto con gli occhi sciacquare subito con acqua e consultare un medico. Lavare subito con acqua e sapone le parti interessate. In caso di ingestione di carburante, contattare subito un medico. Cambiarsi gli abiti se su questi è finito del carburante. Conservare il carburante in una tanica idonea e tenerlo lontano dalla portata dei bambini.

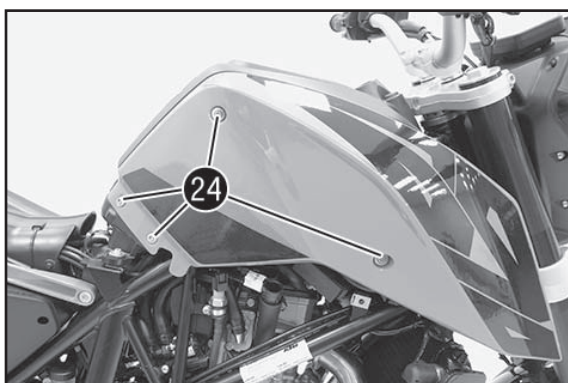

- Rimuovere le viti 24.
- Rimuovere lo spoiler a destra.

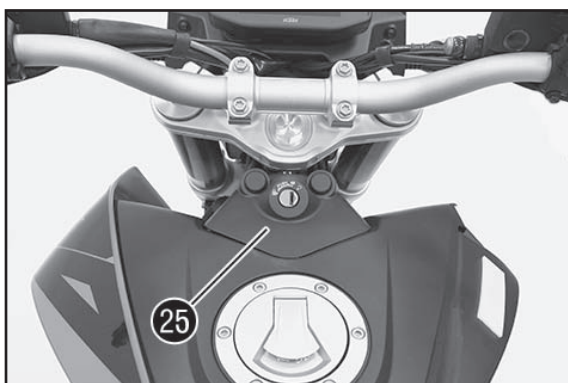

- Per rimuovere il rivestimento 25 tirarlo verso l'alto.

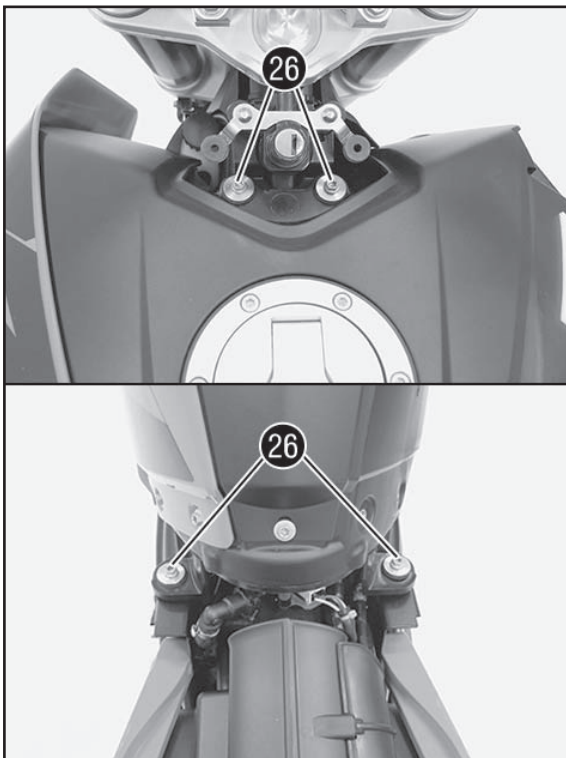

- Rimuovere le viti 26.

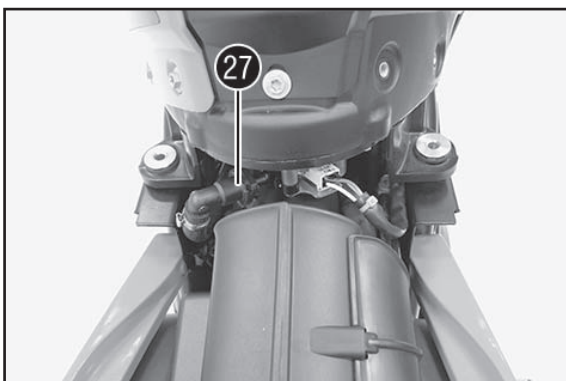

- Scollegare il raccordo del tubo del carburante 27.

AVVERTENZA

Dal tubo del carburante può fuoriuscire del carburante residuo.

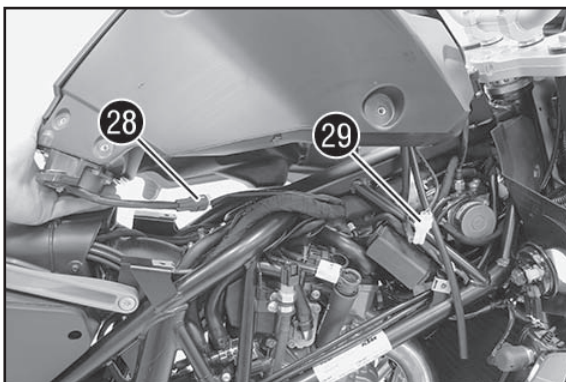

- Sollevare il serbatoio del carburante.

- Scollegare il connettore 28.

- Scollegare il connettore 29.



(Duke)

- Estrarre il tubo di sfiato 30.

- Rimuovere il serbatoio del carburante.

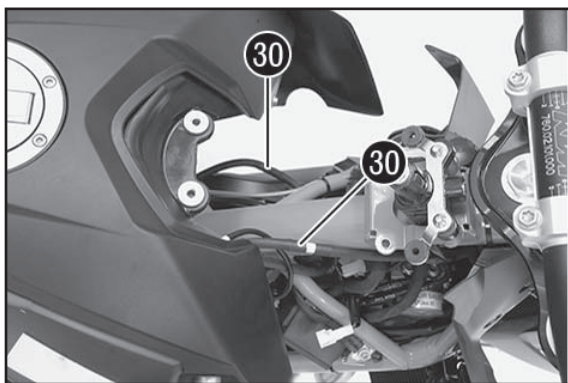

(Duke R)

- Estrarre i flessibili di sfiato 30.
- Rimuovere il serbatoio del carburante.

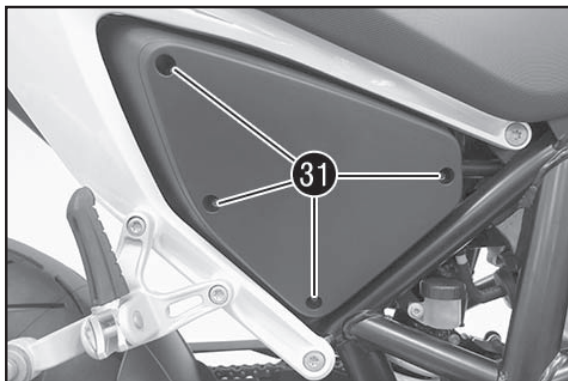

Smontaggio della cassa filtro

- Rimuovere le viti 31.
- Rimuovere il coperchio della cassa filtro.

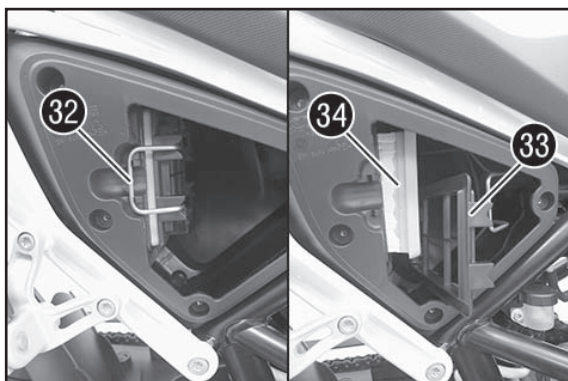

- Sganciare la staffa di ritegno del filtro dell'aria 32 e sposterla lateralmente.

- Rimuovere il telaio del filtro 33 e il filtro dell'aria 34.

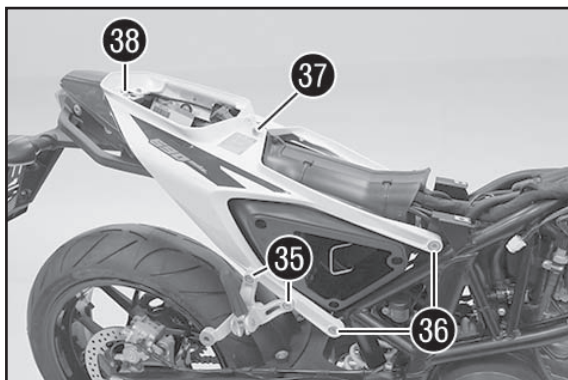

- Rimuovere le viti 35.
- Rimuovere il supporto pedana passeggero.
- Rimuovere le viti 36.
- Rimuovere la vite 37.
- Rimuovere la vite 38.

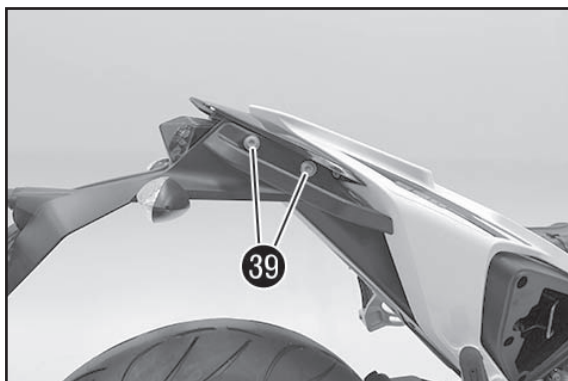

- Rimuovere le viti 39 da entrambi i lati.
- Rimuovere le maniglie.

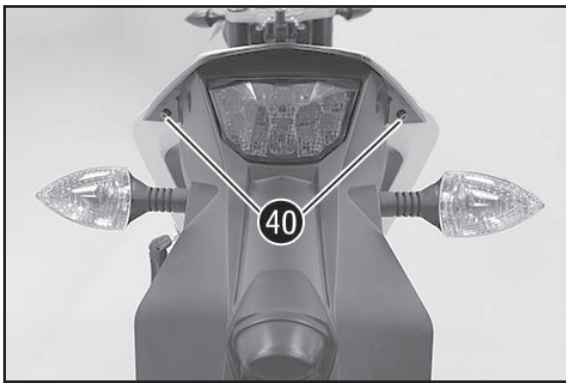

- Rimuovere le viti 40.
- Rimuovere la copertura posteriore.

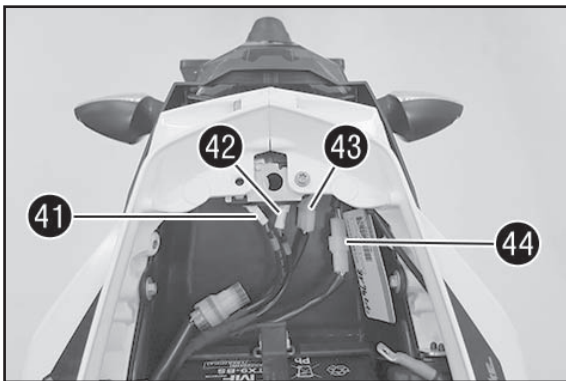

- Scollegare il connettore 41.
- Scollegare il connettore 42.
- Scollegare il connettore 43.
- Scollegare il connettore 44.
- Sfilare il cavo e rimuovere il portatarga.

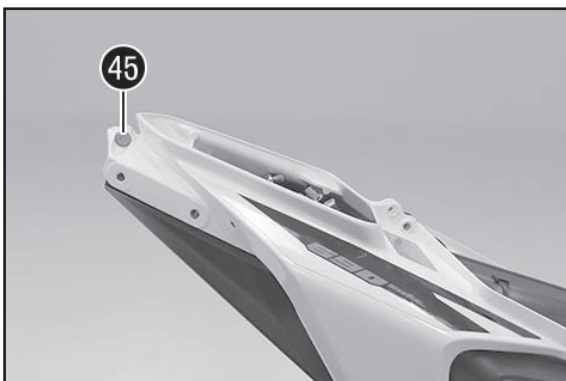

- Rimuovere la vite 45.

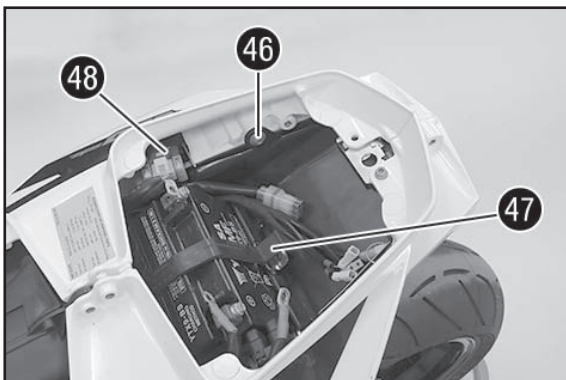

- Rimuovere la vite 46.
- Sganciare il gommino di fissaggio 47.
- Rimuovere la batteria dal suo supporto tirandola verso l'alto.
- Staccare il relè di avviamento 48 dalla piastrina.

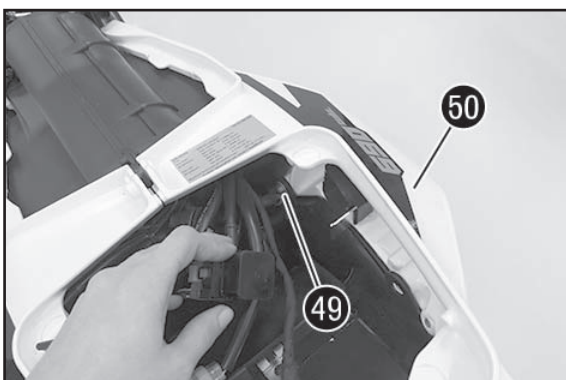

- Rimuovere la vite 49.
- Rimuovere la parte posteriore destra 50.

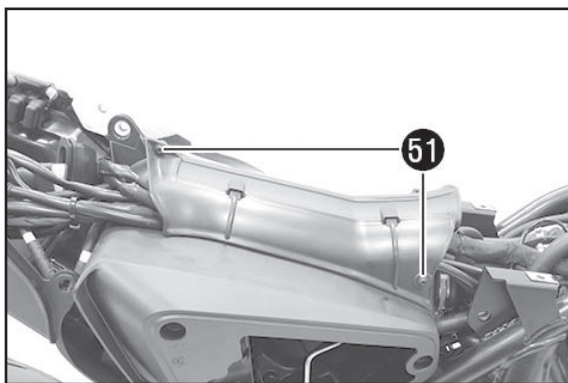

- Rimuovere le viti 51.
- Rimuovere la copertura destra dei cavi.

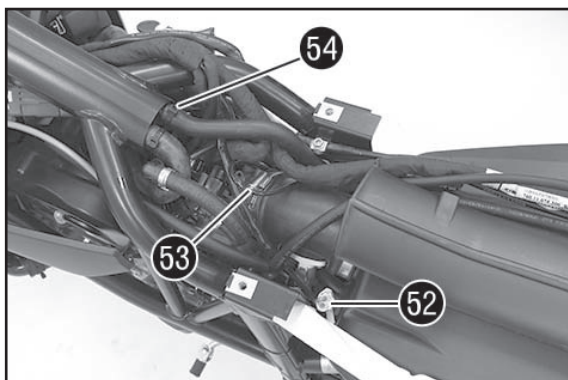

- Scollegare il connettore 52.
- Allentare la fascetta stringitubo 53.
- Rimuovere la fascetta serracavi 54.
- Estrarre il tubo di sfiato.

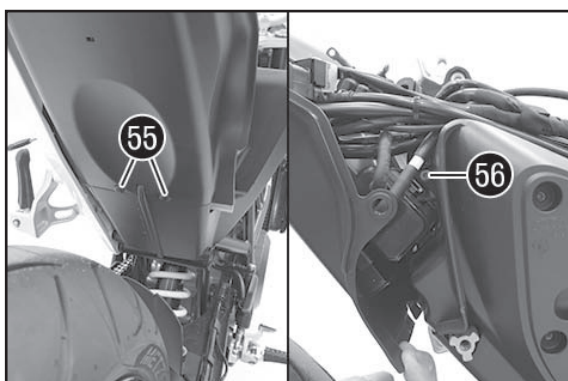

- Rimuovere il tappo 55.
- Rimuovere la vite 56.

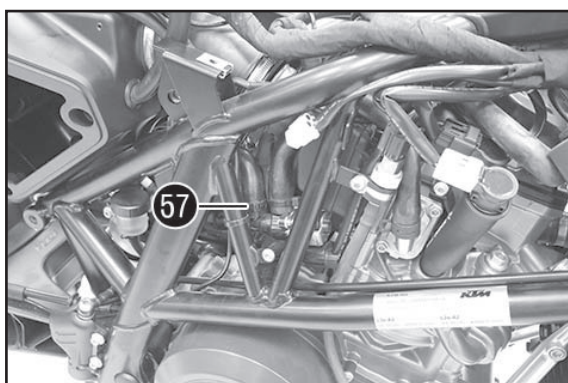

- Rimuovere la fascetta serracavi 57.
- Staccare il tubo flessibile dell'impianto dell'aria secondaria.

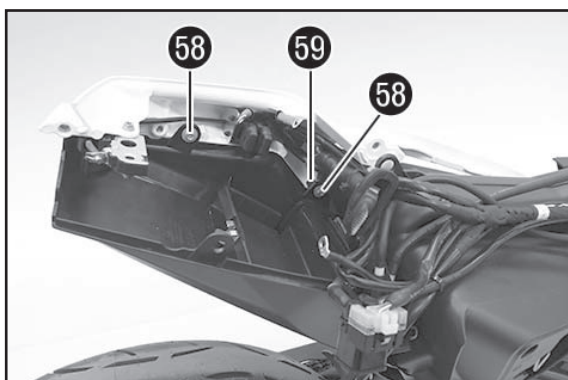

- Rimuovere le viti 58.
- Rimuovere il supporto per il comando a cavo flessibile della serratura della sella 59.
- Rimuovere il supporto batteria.

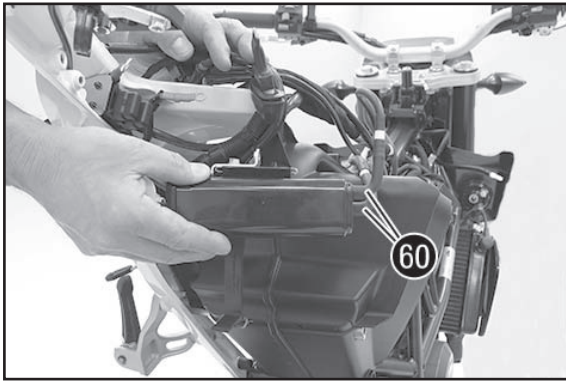

- Estrarre i tubi 60.
- Rimuovere il filtro ai carboni attivi.

AVVERTENZA

Il filtro ai carboni attivi non viene rimontato.

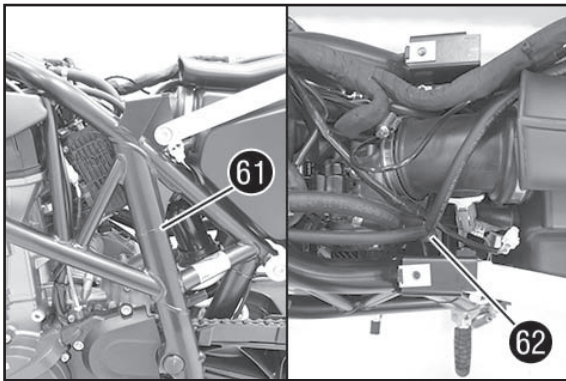

- Rimuovere la fascetta serracavi 61.
- Rimuovere il raccordo a Y 62 con i tubi flessibili.

AVVERTENZA

I tubi non vengono rimontati.

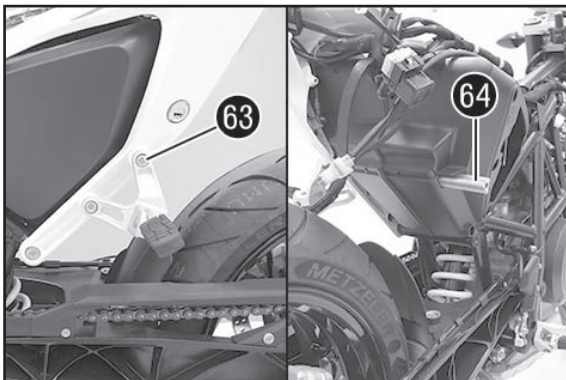

- Rimuovere la vite 63.
- Rimuovere il manicotto 64 verso destra.

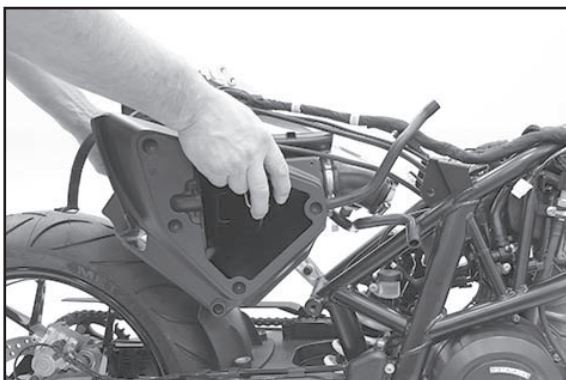

- Rimuovere la cassa filtro.

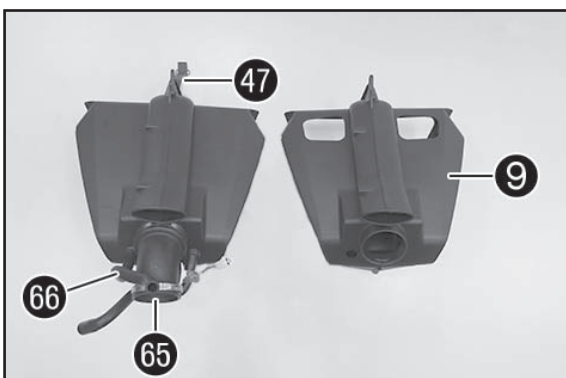

Premontaggio della cassa filtro

- Smontare il gommino di fissaggio 47, la trombeta d'aspirazione 65 con fascetta stringitubo e tubo di sfiato 66 dalla cassa filtro originale e rimontarlo sulla cassa filtro 9 (in dotazione).

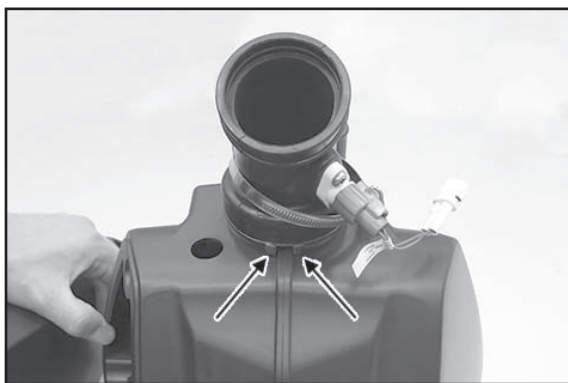

AVVERTENZA

Montare la trombetta d'aspirazione come illustrato.

- ✓ I naselli d'ancoraggio posizionano la trombetta d'aspirazione sul traversino (v. freccia).

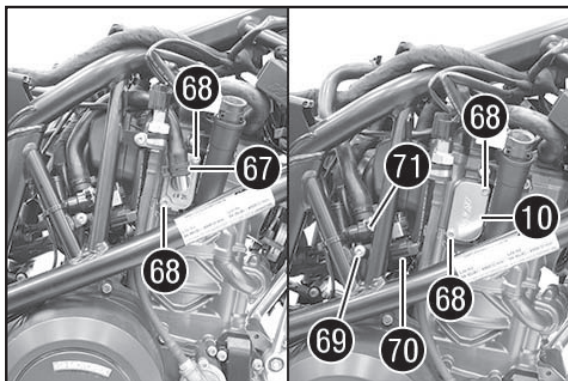

Smontaggio dell'impianto aria secondaria

- Allentare la fascetta elastica a nastro **67** ed estrarre il tubo flessibile dell'impianto aria secondaria.
- Rimuovere le viti **68**.
- Rimuovere il coperchio.
- Posizionare il coperchio dell'impianto aria secondaria **10** (in dotazione).
- Montare le viti originali **68** e serrarle a 10 Nm.
- Rimuovere la vite **69**.
- Scollegare il connettore **70**, posizionare il cavo in modo che non presenti punti in tensione e fissarlo al cablaggio con la fascetta serracavi.
- Rimuovere la valvola dell'impianto aria secondaria **71** con il tubo flessibile.

AVVERTENZA

La valvola dell'impianto aria secondaria non viene rimontata.

Kit smontaggio EVAP

- Estrarre il tubo flessibile **72** sul lato sinistro.
- Rimuovere la valvola **73**.

AVVERTENZA

Il tubo flessibile e la valvola non vengono rimontati.

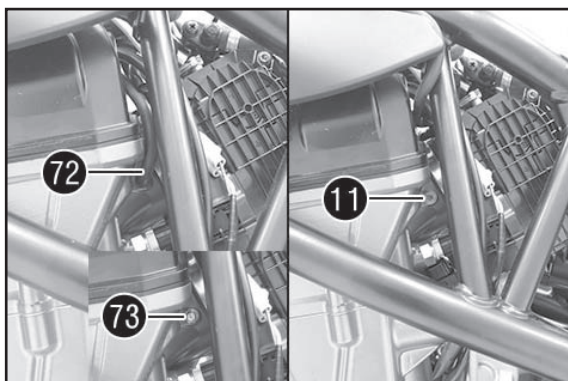

- Montare la vite con l'anello di tenuta **11** (entrambi in dotazione) e serrare a 10 Nm (Loctite 243).

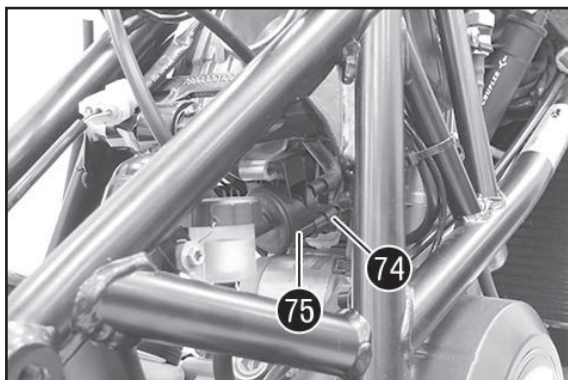

- Scollegare il connettore **74**, posizionare il cavo in modo che non presenti punti in tensione e fissarlo al cablaggio con la fascetta serracavi.
- Estrarre la valvola EVAP **75** dalla piastrina e rimuovere con i tubi flessibili.

AVVERTENZA

La valvola EVAP non viene rimontata.

Montaggio della cassa filtro

- Posizionare la cassa filtro **9** (in dotazione).
- Montare la trombetta d'aspirazione **65**.
- Posizionare e stringere la fascetta stringitubo **53**.

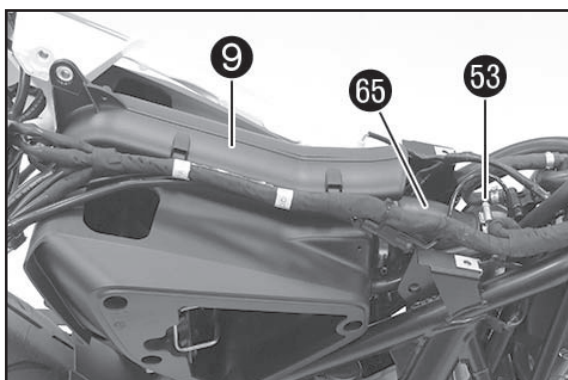

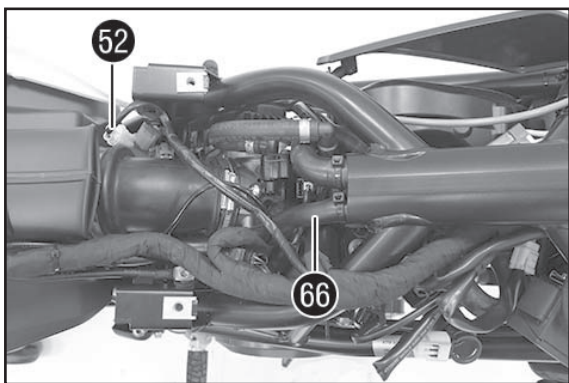

- Collegare il connettore 52.
- Montare il tubo di sfiato 66 e assicurarlo con una fascetta serracavi.

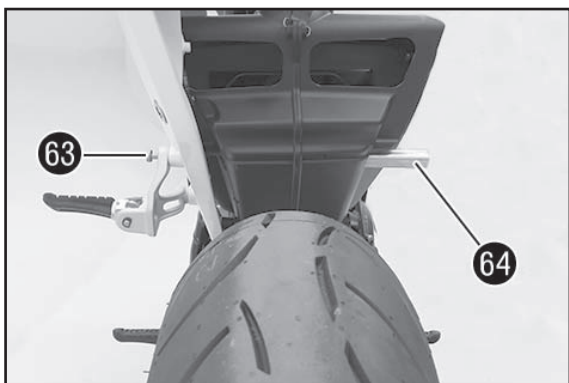

- Montare il manicotto originale 64.
- Montare la vite originale 63, ma non serrarla ancora.

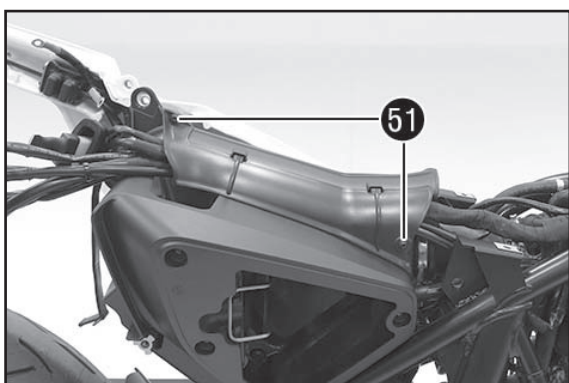

- Posizionare la copertura destra dei cavi.
- Montare e serrare le viti originali 51.

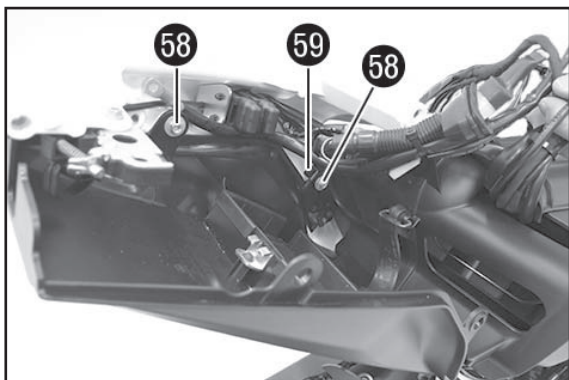

- Posizionare il supporto batteria.
- Posizionare il supporto per il comando a cavo flessibile della serratura della sella 59 e agganciare il comando a cavo flessibile.

AVVERTENZA

Il supporto per il comando a cavo flessibile viene posizionato nella parte anteriore.

- Montare le viti originali 58 e serrarle a 10 Nm.



- Montare il tappo originale 55.

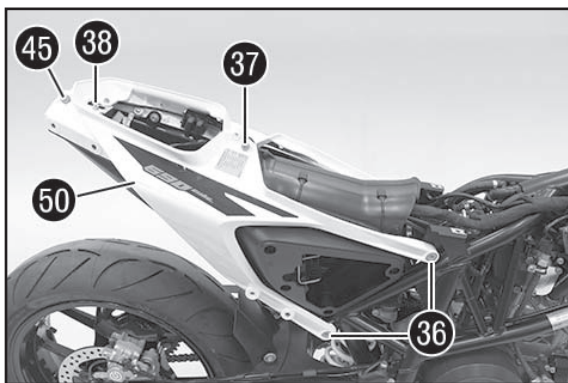

- Posizionare la parte posteriore destra 50.
- Montare le viti originali 36, 37, 38, ma non serrarle ancora.
- Montare la vite originale 45 e serrarla a 25 Nm (Loctite 243).
- Serrare le viti 36 a 45 Nm.
- Serrare la vite 37 a 25 Nm (Loctite 243).
- Serrare la vite 38 a 10 Nm (Loctite 243).

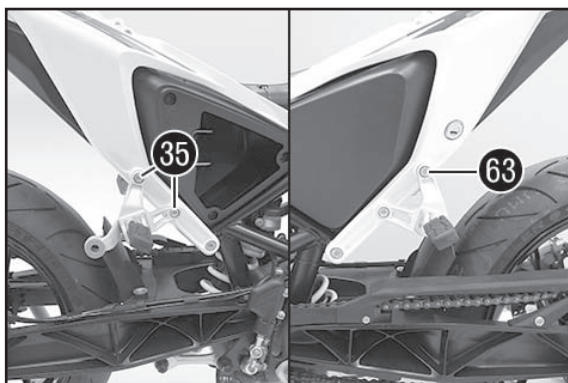

- Posizionare il supporto pedana passeggero.
- Montare le viti originali 35 e serrarle a 25 Nm (Loctite 243).
- Montare la vite originale 63 e serrarla a 25 Nm (Loctite 243).

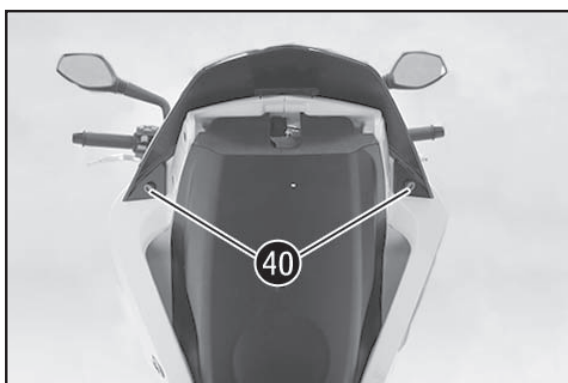

- Posizionare la copertura posteriore.
- Montare le viti originali 40 e serrarle a 10 Nm.

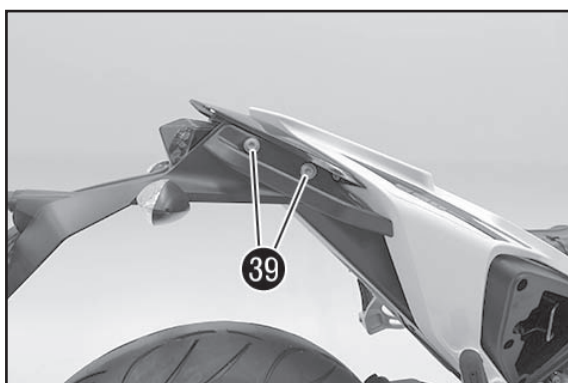

- Sfilare il cavo e posizionare il portatarga.
- Posizionare le maniglie.
- Montare le viti originali 39 e serrarle a 18 Nm (Loctite 243).

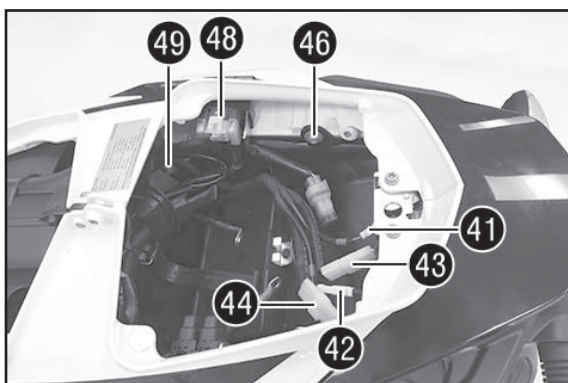

- Collegare il connettore 41.
- Collegare il connettore 42.
- Collegare il connettore 43.
- Collegare il connettore 44.
- Montare la vite originale 46 e serrarla a 10 Nm.
- Montare la vite originale 49 e serrarla a 10 Nm.
- Montare il relè di avviamento 48 sulla piastrina.

! AVVERTIMENTO

Posare tutti i cavi in modo corretto ed eventualmente fissarli con la fascetta serracavi. Assicurarsi che i cavi non rischiano di essere piegati o bloccati!

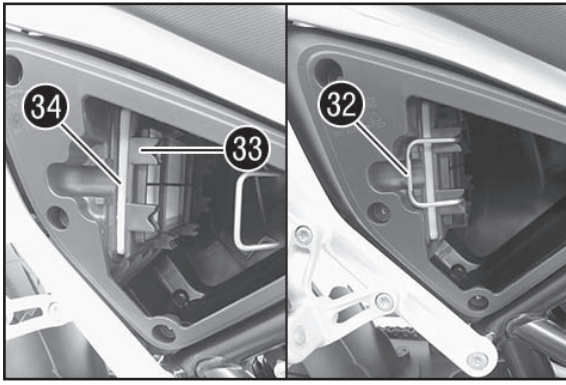

- Posizionare il filtro dell'aria 34 e il telaio del filtro 33.
- Posizionare e agganciare la staffa di ritegno del filtro dell'aria 32.

AVVERTENZA

La staffa di ritegno deve risultare completamente dentro le sedi del telaio del filtro.

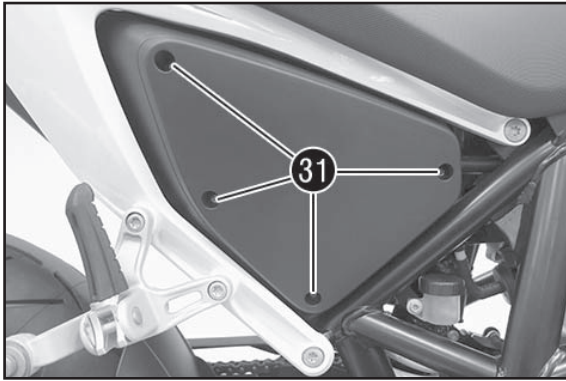

- Montare il coperchio della cassa filtro.
- Montare le viti originali 31 e serrarle a 3 Nm.

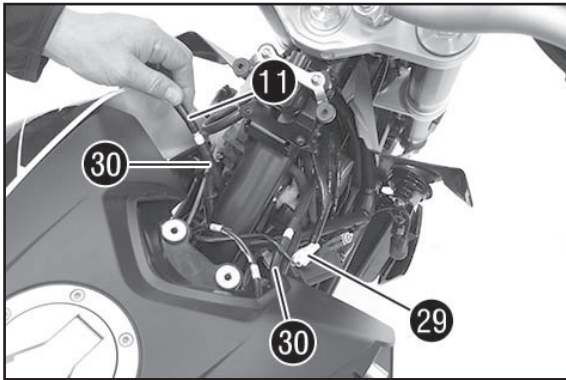

Montaggio del serbatoio

- Sollevare il serbatoio.
- Collegare il connettore 29.
- Montare il tubo di sfiato 30.
- Far passare il tubo di sfiato 30 all'altro lato.
- Montare il tubo di sfiato 11 (in dotazione).

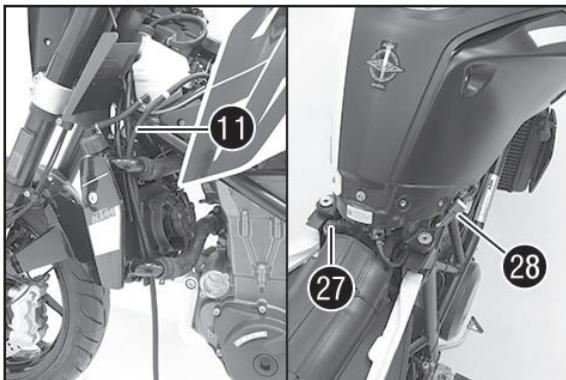

- Posizionare il tubo di sfiato 11 verso il basso in modo che non presenti punti in tensione.

AVVERTENZA

Se il tubo flessibile è troppo lungo, accorciarlo.

- Posizionare il serbatoio.
- Collegare il raccordo del tubo del carburante 27 utilizzando un nuovo O-ring.
- Collegare il connettore 28.



- Montare le viti originali 26 e serrarle a 10 Nm.

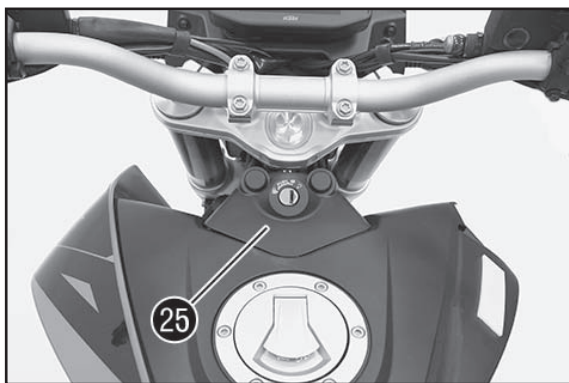

- Montare il rivestimento 25.

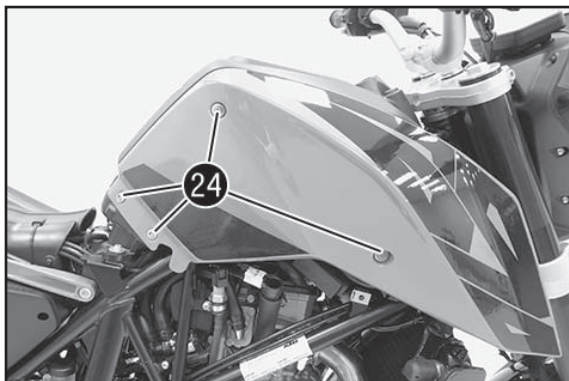

- Posizionare lo spoiler.
- Montare le viti originali 24 e serrarle a 3 Nm.

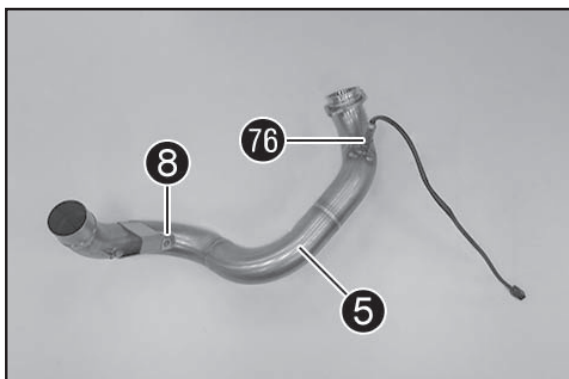

Premontaggio del collettore

- Smontare la sonda lambda 76 dal collettore originale e rimontarla sul collettore 5 (in dotazione).
- Montare il dado universale per lamiera 8 (in dotazione).

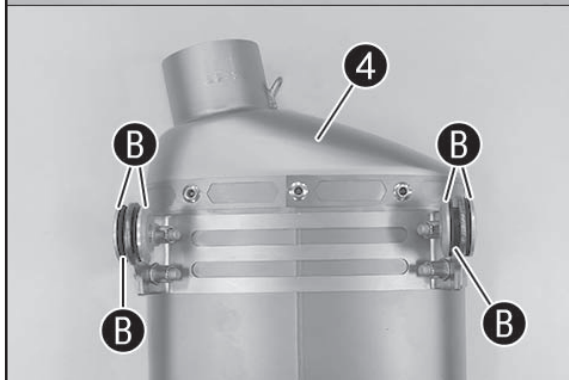

- Montare le bussole in gomma (in dotazione con il kit di montaggio B) sul supporto del presilenziatore 4 (in dotazione).
- Montare le bussole argentate (in dotazione con il kit di montaggio B) a sinistra e destra sulle bussole in gomma.

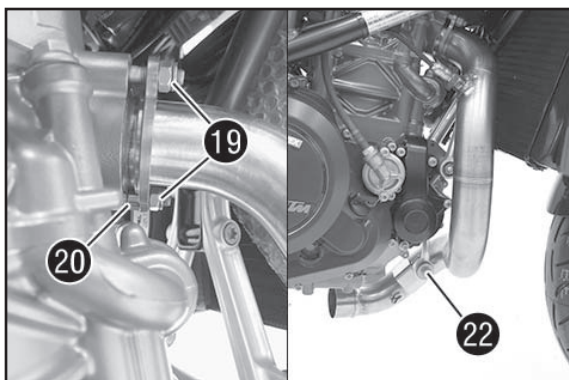

Montaggio dell'impianto di scarico

- Posizionare il collettore 5 (in dotazione) con la guarnizione.
- Montare i dadi originali 19 con la bussola distanziale 20, ma non serrarli ancora.

- Montare la vite originale 22 con la rondella, ma non serrarla ancora.

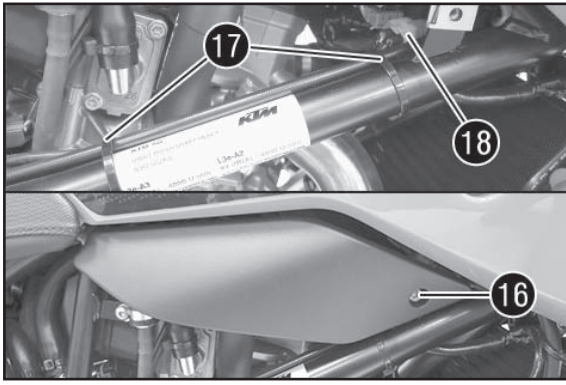

- Collegare il connettore **18** della sonda lambda. Assicurare il cavo con le fascette serracavi **17**.

- Montare il rivestimento destro e sinistro.
- Montare le viti originali **16** su entrambi i lati e serrarle a 3 Nm.

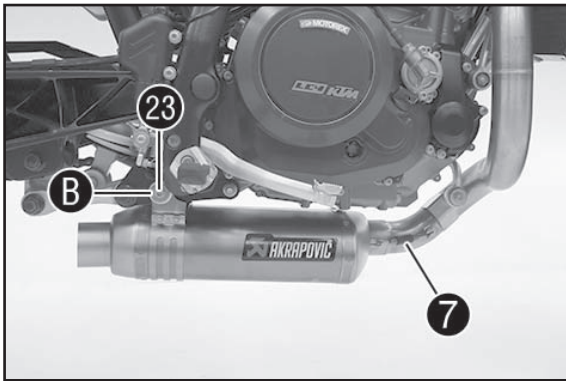

- Posizionare il presilenziatore **4** (in dotazione).
- Montare le viti originali **23** con le rondelle (in dotazione con il kit di montaggio **5**) su entrambi i lati, ma non serrarle ancora.
- Montare la molla corta dell'impianto di scarico **7** (in dotazione).

- Serrare i dadi **19** in modo uniforme a 20 Nm (pasta al rame).
- Serrare la vite **22** a 25 Nm.
- Serrare le viti **23** su entrambi i lati a 25 Nm.

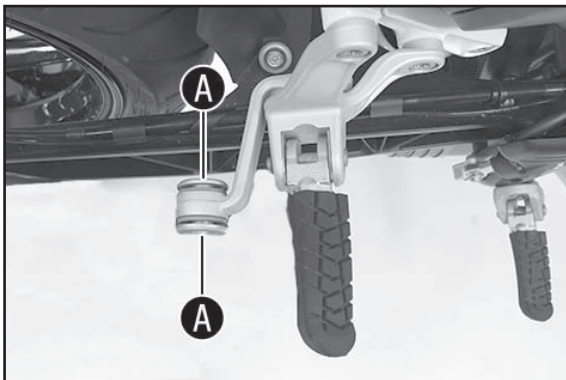

(solo Duke)

- Montare le bussole (in dotazione con il kit di montaggio **A**) sulla guarnizione originale.

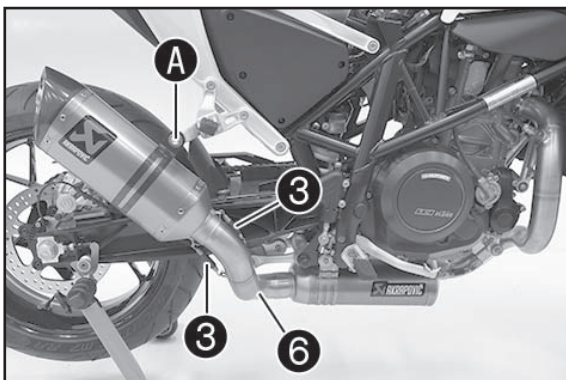

(Duke)

- Montare la curva **6** (in dotazione) sul presilenziatore.
- Montare il silenziatore **1** (in dotazione) sul collare dello scarico **2** (in dotazione).
- Montare la vite (in dotazione con il kit di montaggio **A**) con la rondella originale e il dado con la rondella (entrambi in dotazione con il kit di montaggio **A**) e serrarli a 15 Nm.
- Agganciare le molle lunghe dell'impianto di scarico **3** (in dotazione).

(Duke R)

- Montare la curva **6** (in dotazione) sul presilenziatore.
- Montare il silenziatore originale con il collare dello scarico.
- Montare la vite originale **15** con la rondella e serrarla a 15 Nm.
- Agganciare le molle lunghe dell'impianto di scarico **3** (in dotazione).

(solo Duke)

- Agganciare la molla corta dell'impianto di scarico **7** (in dotazione).

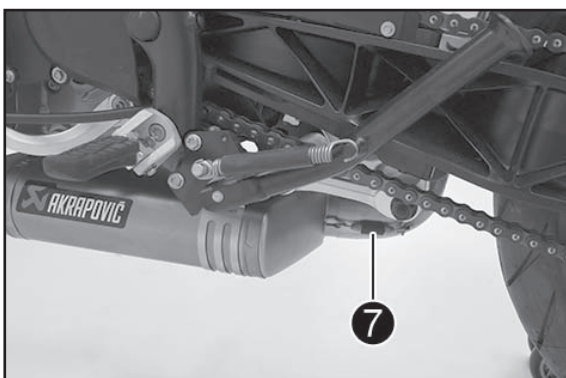

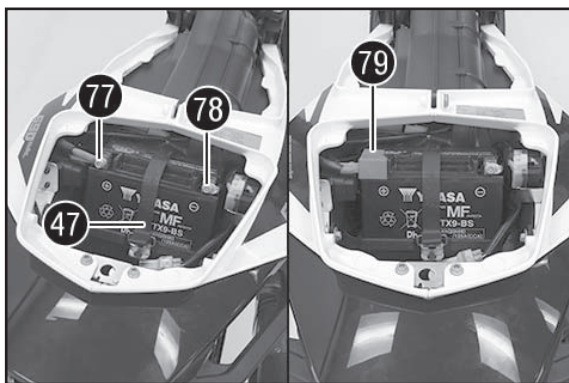

Montaggio della batteria

- Posizionare la batteria nell'apposito supporto.
- ✓ I poli della batteria sono rivolti in senso contrario rispetto a quello di marcia.
- Agganciare il gommino di fissaggio 47.
- Collegare entrambi i cavi positivi 77 alla batteria e serrare la vite a 2 Nm.
- Collegare il cavo negativo 78 alla batteria e serrare la vite a 2 Nm.
- Montare il cappuccio del polo positivo 79.

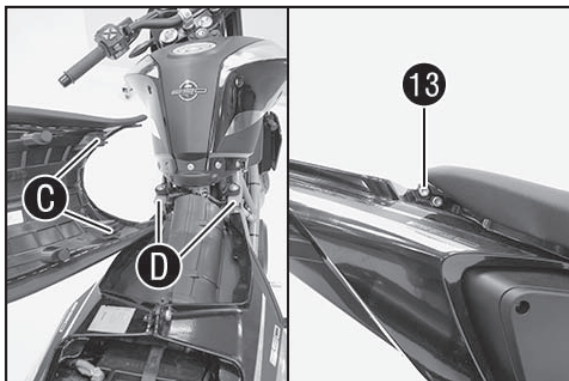

Montaggio della sella del pilota

- Spingere la sella in avanti e abbassarla facendo pressione sulla parte posteriore.
- ✓ I naselli C si innestano nelle alette D del telaio.
- Montare la vite 13 e serrare a 25 Nm.
- Al termine controllare che la sella del conducente sia montata correttamente.

Operazione conclusiva

- Montare la sella del passeggero (v. manuale d'uso).
- Rimuovere la motocicletta dal cavalletto alzamoto posteriore (v. manuale d'uso).



! AVVERTIMENTO

Durante la prima messa in funzione del silenziatore, mantenere basso il regime del motore per circa 5 minuti, al fine di far riscaldare in modo uniforme il silenziatore. Solo così il materiale isolante può raggiungere la massima efficienza e contenere la rumorosità ai valori desiderati!

Montaggio finale

Assicurarsi che l'impianto di scarico non tocchi altri componenti della motocicletta. Rimuovere eventuali residui di grasso con un panno morbido impregnato di un lubrificante multiuso (Motorex Joker 440). La pulizia impedisce alle macchie di rimanere impresse sulla superficie. Non utilizzare detergenti chimici aggressivi che potrebbero danneggiare gli adesivi. Assicurarsi che tutte le viti siano ben serrate. Se l'impianto di scarico tocca il rivestimento o altri componenti, ripetere la regolazione oppure contattare il proprio rivenditore! È normale che, durante il primo funzionamento dell'impianto di scarico, fuoriesca fumo bianco dal silenziatore! Al termine controllare la tenuta dell'intero impianto di scarico. Al momento della prima accensione, non sostare dietro lo scarico!

Manutenzione dell'impianto di scarico

Pulire con uno spray lubrificante multiuso (Motorex Joker 440). A causa dell'alta temperatura, è normale che l'impianto di scarico cambi colore. Il grado di usura del materiale isolante del silenziatore dipende dal tipo di motore e dallo stile di guida. Contattare il proprio concessionario nel caso in cui si notino modifiche visibili sul rivestimento esterno del silenziatore o se il livello di rumorosità dovesse risultare troppo alto. Controllare periodicamente che tutte le viti siano ben avvitate e che le molle siano ben in sede.

Parti di ricambio

Kit materiale fonoassorbente

76005979010

- Lana minerale
- n. 14 rivetti D4,8x8
- n. 2 rivetti D4,8x12

Kit di riparazione

76005979220

- n. 1 rivestimento esterno in titanio
- n. 2 fascette di rinforzo in titanio
- n. 14 rivetti D4,8x8
- n. 2 rivetti D4,8x12
- n. 1 adesivo
- n. 1 adesivo con numero di brevetto

n. 1 collare dello scarico in carbonio ②

76005979001

n. 1 fondello in carbonio ⑧⑩

76005979005

n. 2 molle lunghe dell'impianto di scarico ③

57305016000

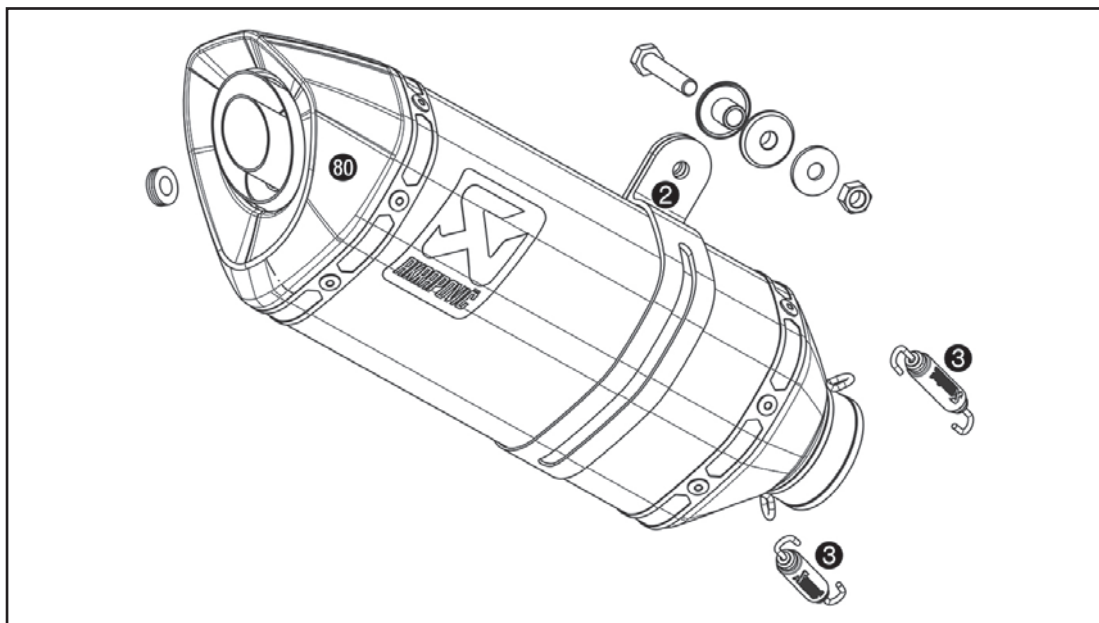

» ITALIANO

Parti di ricambio

n. 1 adesivo Akrapovic ⑥③

60005099003

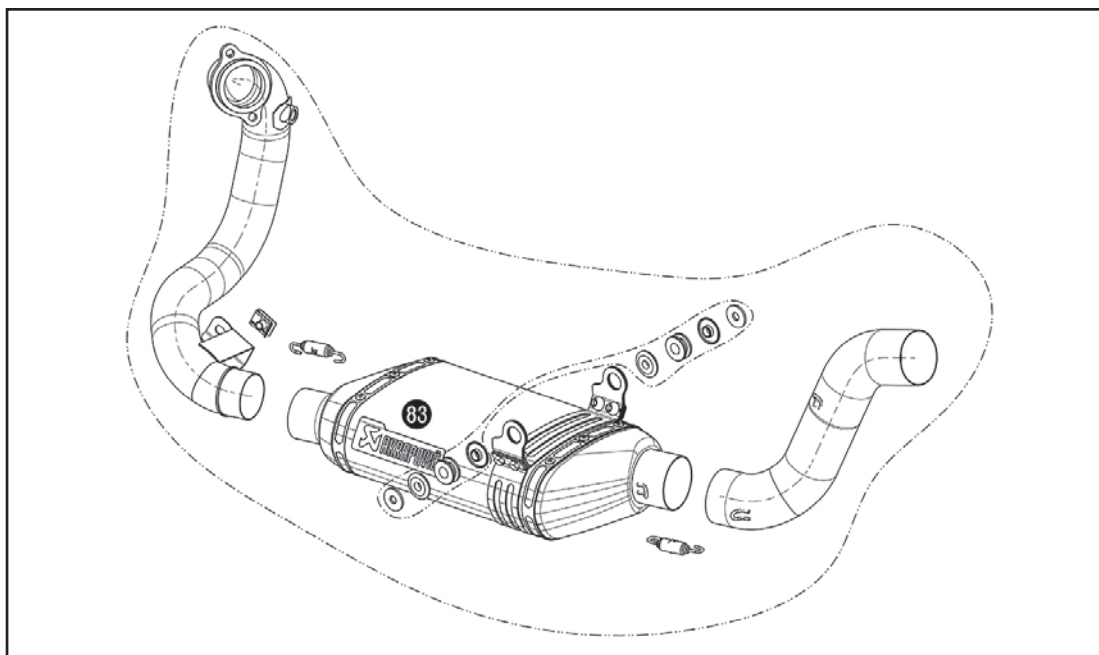

Nous recommandons de faire monter le kit de tuning uniquement par un atelier agréé ou un mécanicien qualifié. Un montage incorrect risque d'entraîner une durée de vie réduite ou un endommagement de la moto!



Contenu de la livraison 76612945000 (690 Duke uniquement)

- 1x silencieux arrière AKRAPOVIC ① 76005979200
- 1x collier d'échappement en carbone ②
- 2x ressorts d'échappement longs ③
- 1x kit de montage ④

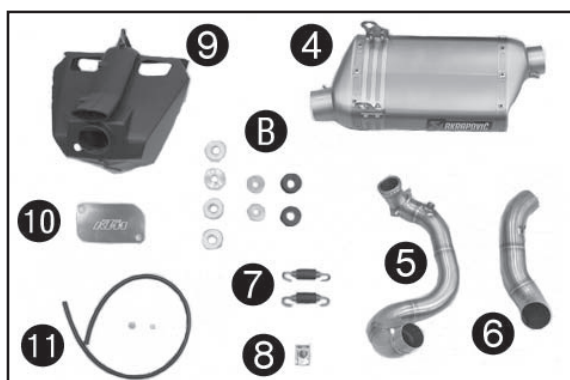

Contenu de la livraison 76612945000 et 76612945100

- Kit collecteur AKRAPOVIC EVO 76005907100
- 1x pré-silencieux avant ④
- 1x collecteur ⑤
- 1x tube d'échappement ⑥
- 2x ressorts d'échappement courts ⑦
- 1x écrou en tôle ⑧
- 1x kit de montage ⑨
- 1x boîtier du filtre à air tuning ⑩ 76006901000
- 1x bouchon du système de ventilation secondaire ⑪ 60005022200
- 1x kit de démontage EVAP ⑫ 76015999044



⚠ ATTENTION

Ce kit de tuning n'est pas homologué pour une circulation sur route !

Le système peut uniquement être monté et utilisé en liaison avec le Mapping EFI AKRAPOVIC spécial. Le Mapping doit impérativement être installé chez le concessionnaire avant la première utilisation !

- Mapping EFI AKRAPOVIC (690 Duke) 76641033131
- Mapping EFI AKRAPOVIC (690 Duke R) 76641033132

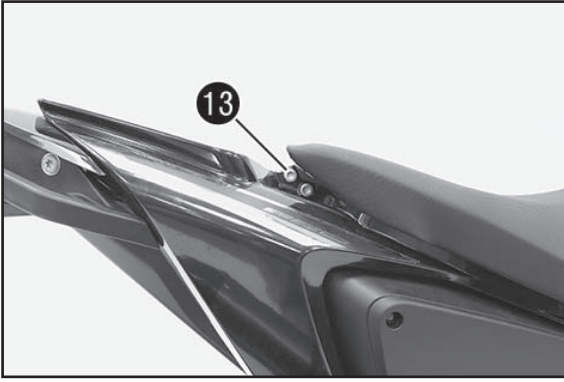

Travaux préalables

- Relever la moto avec le dispositif de levage arrière (voir manuel d'utilisation).
- Déposer la selle passager (voir manuel d'utilisation).
- Débrancher la batterie (voir manuel d'utilisation).

Déposer la selle du pilote

- Retirer la vis **13**.
- Soulever la selle par l'arrière, la tirer et l'enlever par le haut.

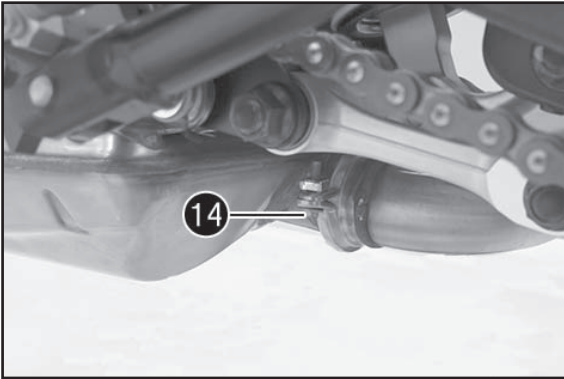

Déposer le silencieux arrière

⚠ Avertissement
Risque de brûlures

Pendant le fonctionnement du véhicule, l'échappement devient très chaud.
- Laisser l'échappement refroidir. Ne pas toucher les pièces brûlantes.

- Retirer la vis **14**. Retirer le collier du silencieux arrière.

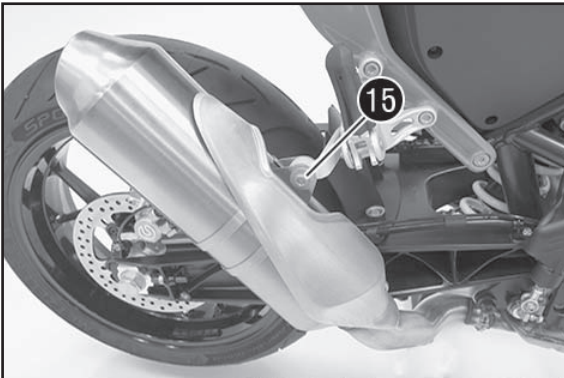

(Duke)

- Retirer la vis **15** avec la rondelle.
- Déposer le silencieux arrière.

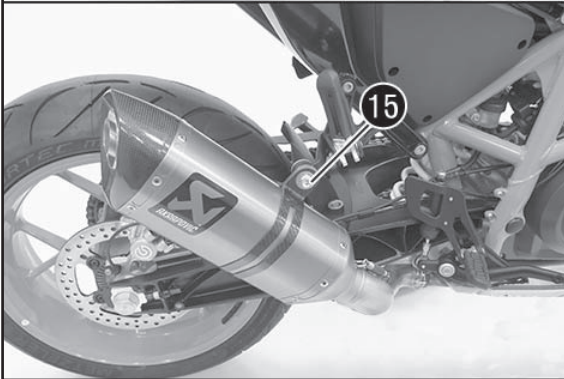

(Duke R)

- Retirer la vis **15** avec la rondelle.
- Déposer le silencieux arrière.

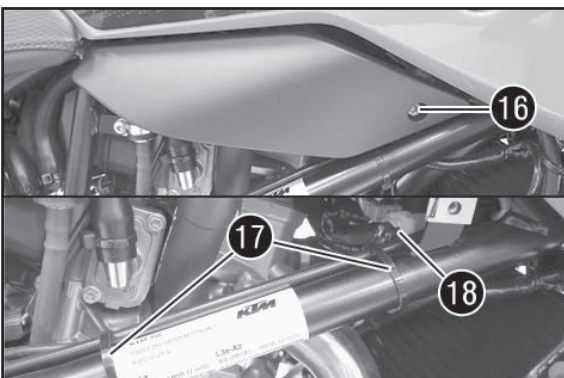

Déposer l'échappement

- Retirer les vis **16** des deux côtés. Retirer les carénages droit et gauche.
- Retirer les serre-câbles **17**. Débrancher le connecteur **18** de la sonde lambda.

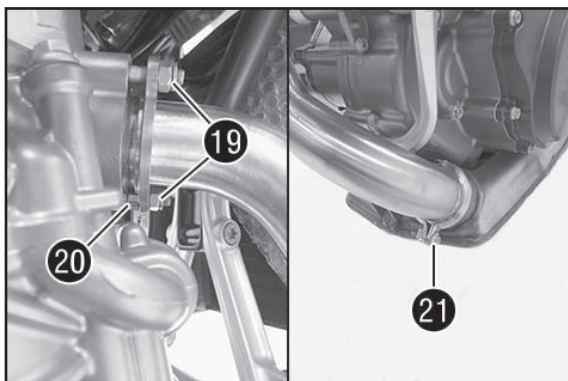

- Retirer les écrous 19.

REMARQUE

Ne pas perdre la douille-entretoise 20.

- Retirer les vis 21. Déposer le collier.
- Déposer le collecteur et le joint.



- Retirer la vis 22 avec la rondelle.
- Retirer les vis 23 des deux côtés.
- Déposer le pré-silencieux avant.

Déposer le réservoir



Danger

Risque d'incendie Le carburant est facilement inflammable.

Ne jamais faire le plein du véhicule à proximité de flammes ou de cigarettes allumées et toujours arrêter le moteur.

Veiller à ne pas répandre de carburant sur des parties brûlantes du véhicule.

Nettoyer immédiatement le carburant répandu.

Le carburant contenu dans le réservoir se dilate sous l'effet de la chaleur et peut déborder lorsque le réservoir est trop rempli.

Respecter impérativement les consignes de remplissage du réservoir de carburant.



Avertissement

Risque d'empoisonnement Le carburant est un produit toxique et nocif pour la santé.

Éviter tout contact de la peau, des yeux ou des vêtements avec le carburant. Ne pas respirer les vapeurs de carburant.

En cas de contact avec les yeux, rincer à l'eau et consulter immédiatement un médecin. Laver immédiatement à l'eau

et au savon les parties contaminées par le carburant. En cas d'ingestion de carburant, consulter immédiatement un

médecin. Changer immédiatement les vêtements contaminés par le carburant. Stocker le carburant conformément

dans un jerrycan approprié et le tenir hors de portée des enfants.

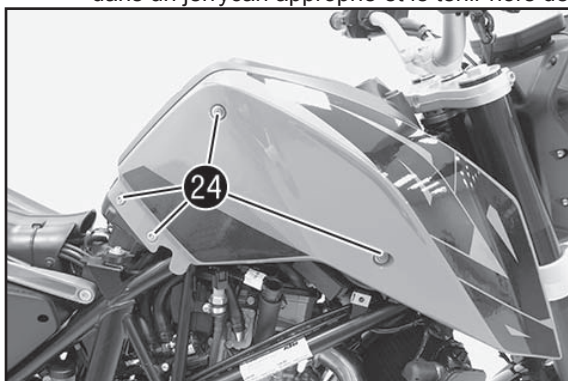

- Retirer les vis 24.
- Déposer le déflecteur de droite.

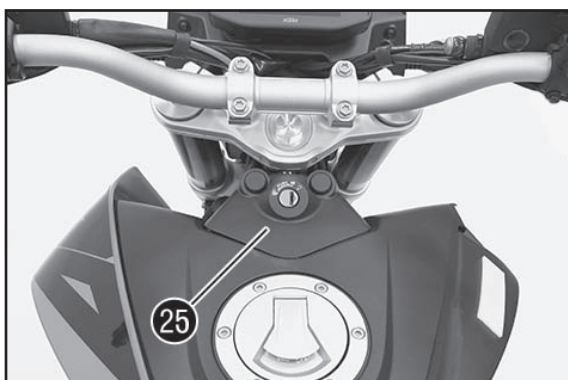

- Tirer le carénage 25 vers le haut et le retirer.

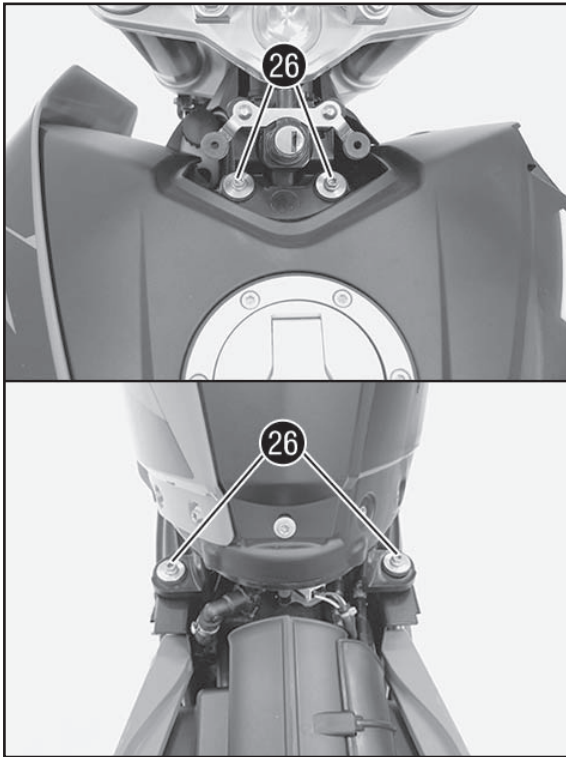

- Retirer les vis 26.

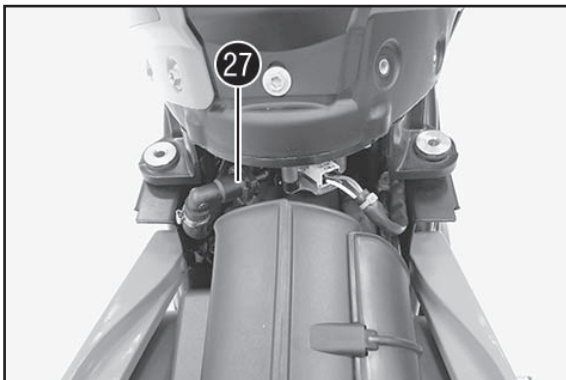

- Débrancher le raccord de flexible à carburant 27.

REMARQUE

Un reste de carburant peut s'écouler de la durite de carburant.

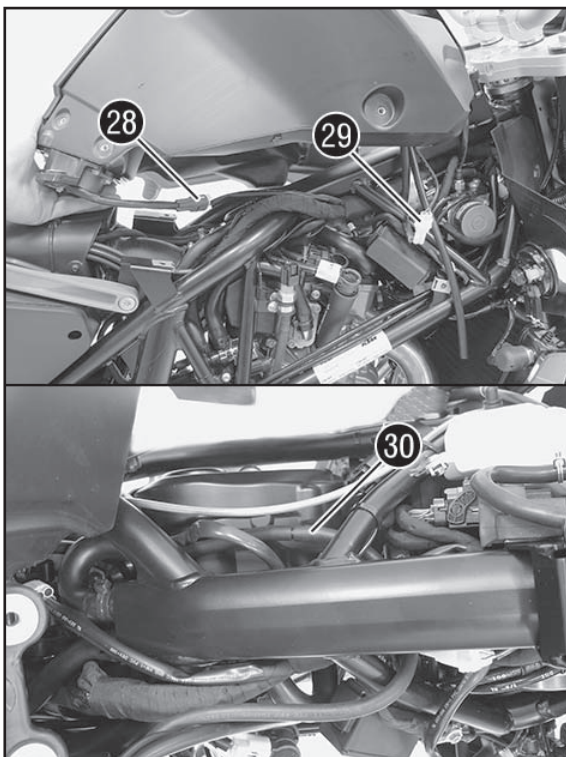

- Soulever le réservoir de carburant.
- Débrancher le connecteur 28.
- Débrancher le connecteur 29.

(Duke)

- Retirer le tuyau de purge 30.
- Déposer le réservoir de carburant.

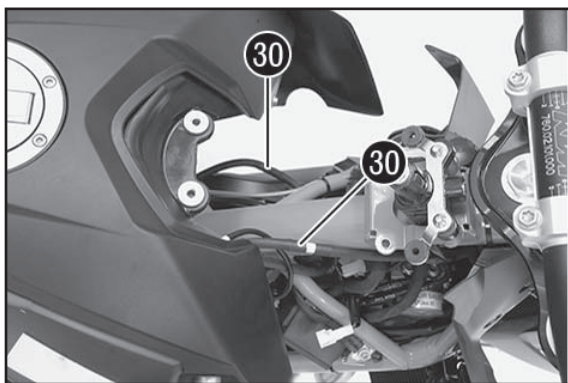

(Duke R)

- Retirer les flexibles de purge 30.
- Déposer le réservoir de carburant.

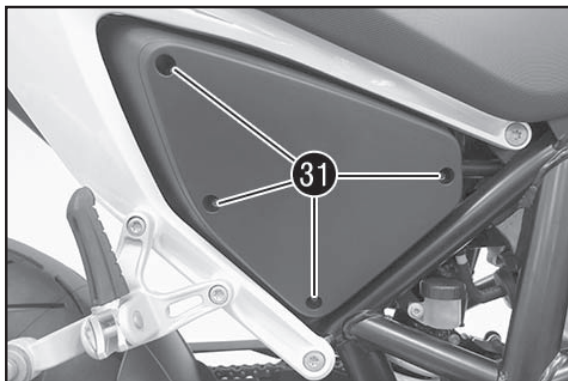

Déposer le boîtier du filtre à air

- Retirer les vis 21.
- Déposer le couvercle du boîtier de filtre à air.

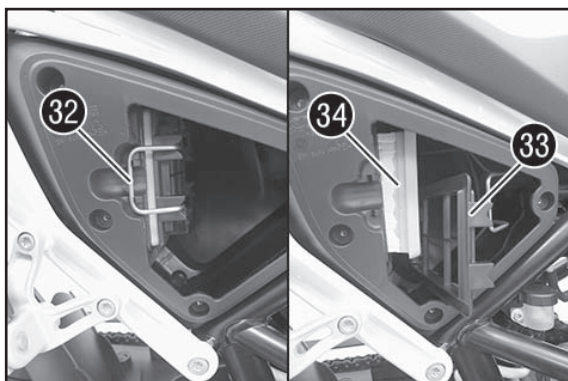

- Décrocher l'étrier de support du filtre à air 32 et le basculer sur le côté.

- Retirer le corps de filtre 33 et le filtre à air 34.

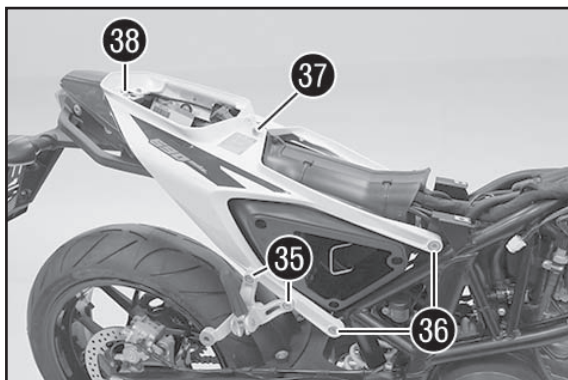

- Retirer les vis 35.
- Retirer le kit repose-pied passager.
- Retirer les vis 36.
- Retirer la vis 37.
- Retirer la vis 38.

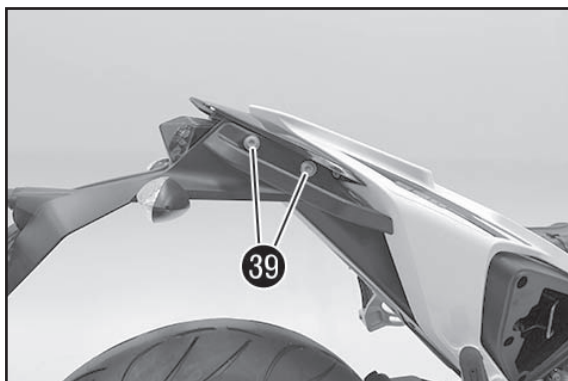

- Retirer les vis 39 des deux côtés.
- Retirer la poignée de retenue.

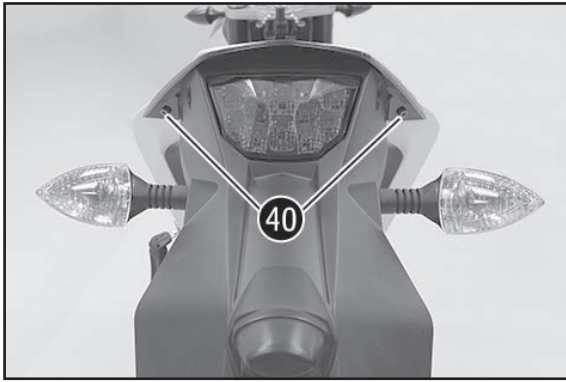

- Retirer les vis 40.
- Retirer le capot arrière.

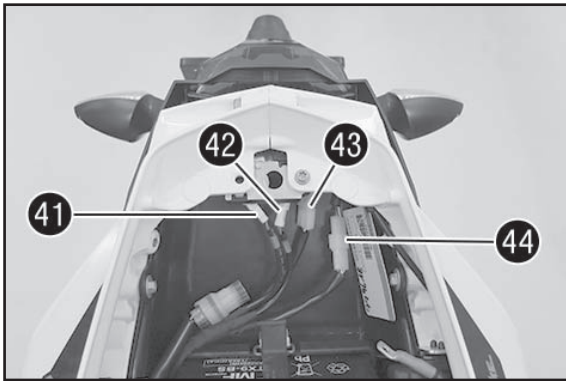

- Débrancher le connecteur 41.
- Débrancher le connecteur 42.
- Débrancher le connecteur 43.
- Débrancher le connecteur 44.
- Dégager le câble et retirer le support de plaque d'immatriculation.

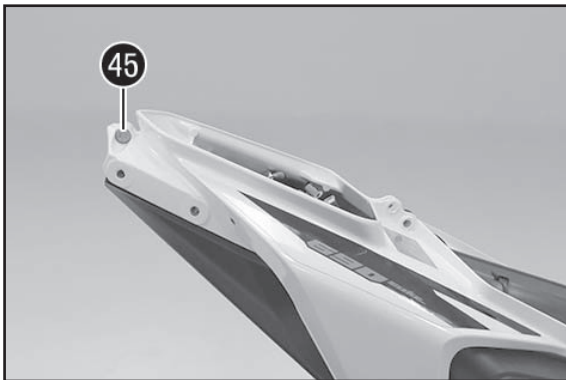

- Retirer la vis 45.

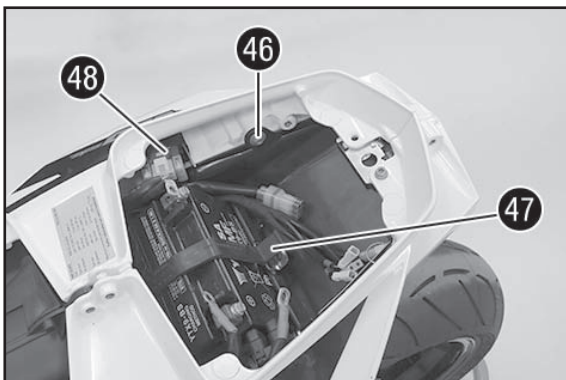

- Retirer la vis 46.
- Décrocher le caoutchouc de maintien 47.
- Sortir la batterie de son support en la tirant vers le haut.
- Retirer le relais de démarrage 48 de la tôle de fixation.

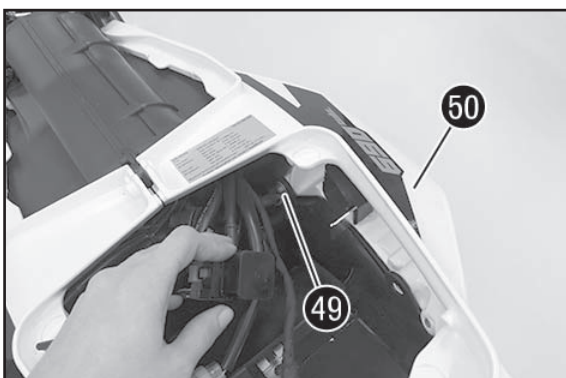

- Retirer la vis 49.
- Retirer le carénage arrière droit 50.

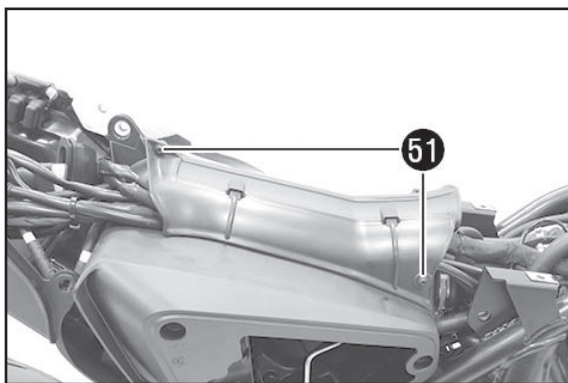

- Retirer les vis 51.
- Retirer le cache câbles droit.

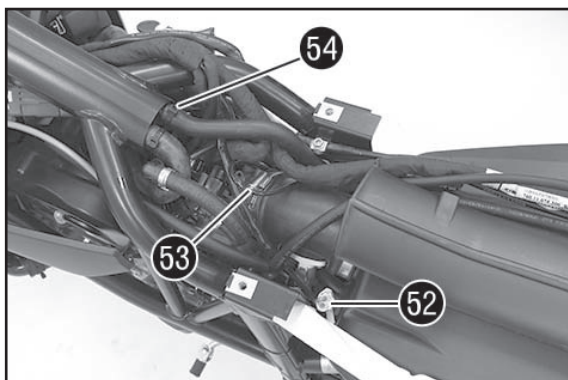

- Débrancher le connecteur 52.
- Desserrer le collier 53.
- Retirer le serre-câble 54.
- Débrancher le tuyau de purge.

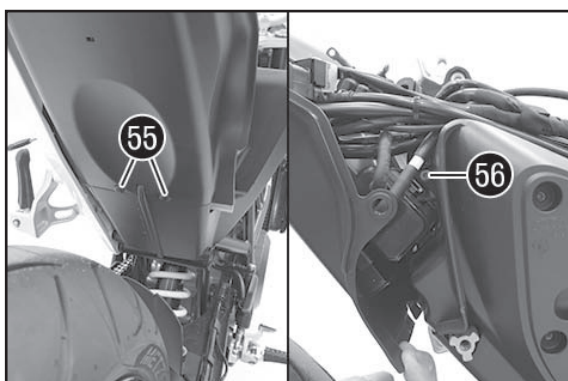

- Retirer les bouchons 55.
- Retirer la vis 56.

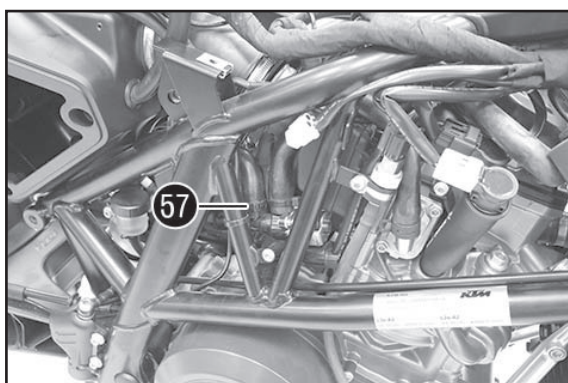

- Retirer le serre-câble 57.
- Débrancher la durite du système de ventilation secondaire.

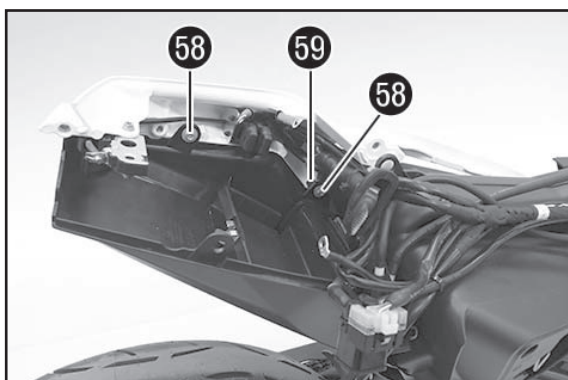

- Retirer les vis 58.
- Retirer le support du câble de commande de la serrure de selle 59.
- Déposer le support de batterie.

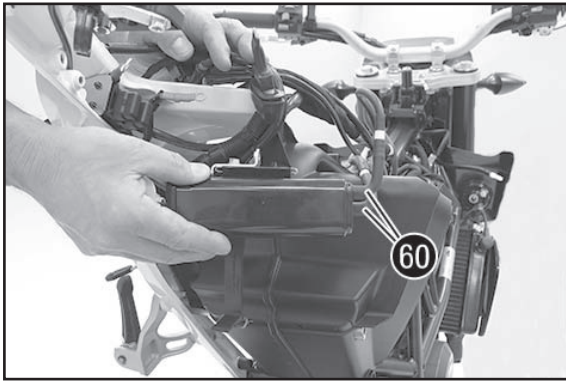

- Retirer les flexibles 60.
- Déposer le filtre à charbon actif.

REMARQUE

Le filtre à charbon actif ne doit plus être remonté.

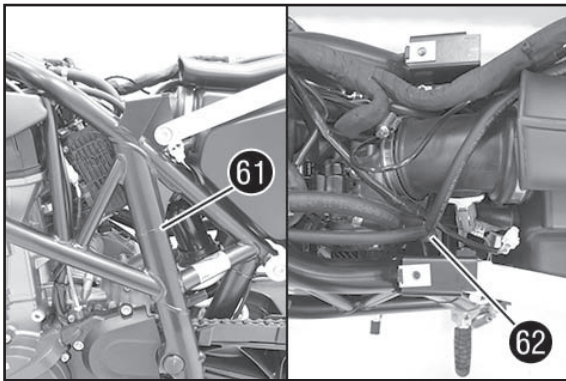

- Retirer le serre-câble 61.
- Retirer la pièce en Y 62 et les flexibles associés.

REMARQUE

Les flexibles ne doivent plus être remontés.

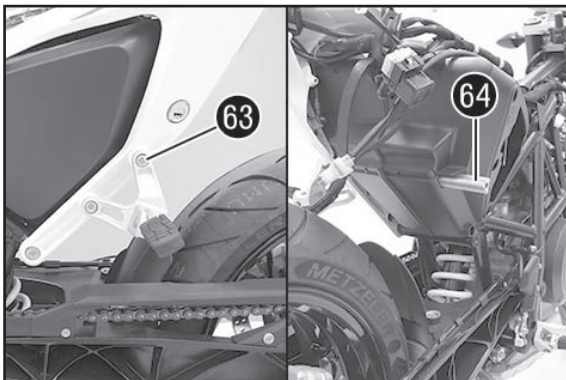

- Retirer la vis 63.
- Retirer la douille 64 vers la droite.

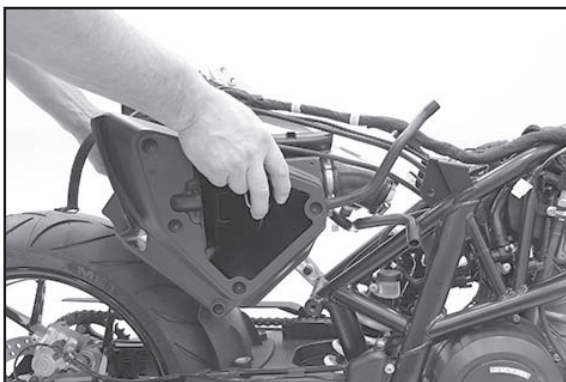

- Déposer le boîtier du filtre à air.

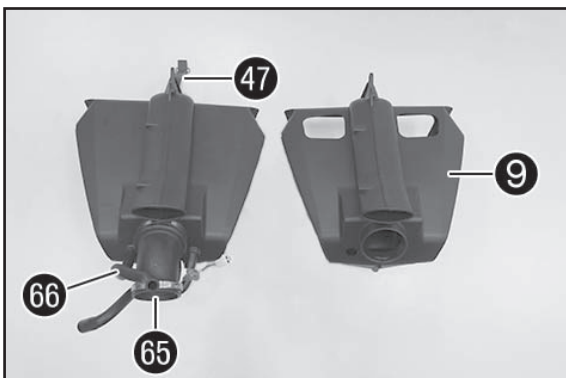

Pré-montage du boîtier du filtre à air

- Démontez le caoutchouc de maintien 47, la trompette d'admission 65, le collier et le tuyau de purge 65 du boîtier du filtre à air d'origine et les remonter sur le nouveau filtre à air 9 (fourni).

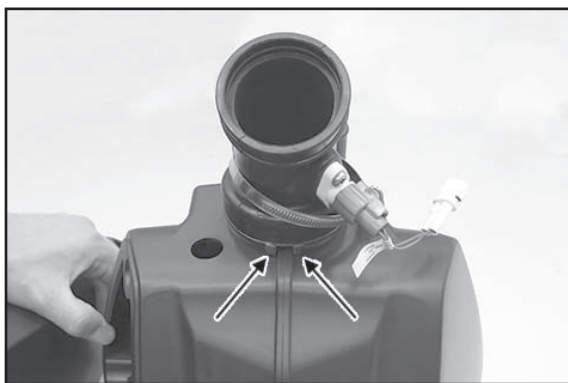

REMARQUE

Monter la trompette d'admission comme indiqué sur l'illustration.

- ✓ Mettre en place les crochets de la trompette d'admission dans la nervure (voir la flèche).

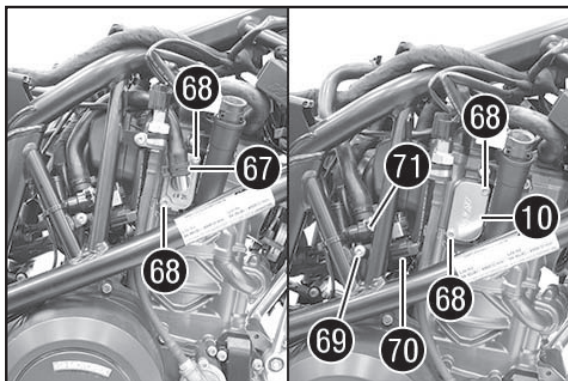

Démontage du système de ventilation secondaire

- Desserrer le clip **67** et retirer le tuyau du système de ventilation secondaire.
- Retirer les vis **68**.
- Déposer le couvercle.
- Mettre en place le couvercle du système de ventilation secondaire **10** (fourni).
- Monter les vis d'origine **69** et les serrer à 10 Nm.
- Retirer la vis **69**.
- Débrancher le connecteur **70**, poser le câble sans tension et le sécuriser au faisceau à l'aide d'un serre-câble.
- Retirer la soupape du système de ventilation secondaire **71** et son flexible.

REMARQUE

La soupape du système de ventilation secondaire ne doit pas être remontée.

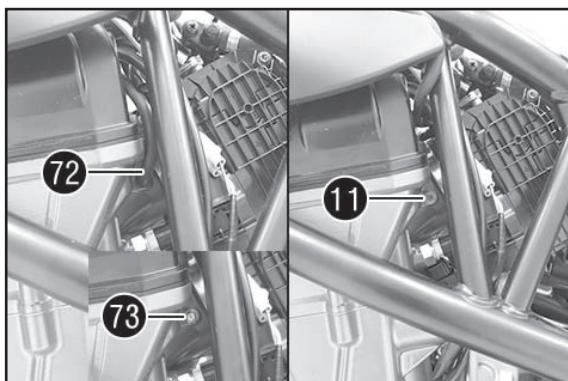

Kit de démontage EVAP

- Retirer le flexible **72** du côté gauche.
- Retirer la soupape **73**.

REMARQUE

Le flexible et la soupape ne doivent pas être remontés.

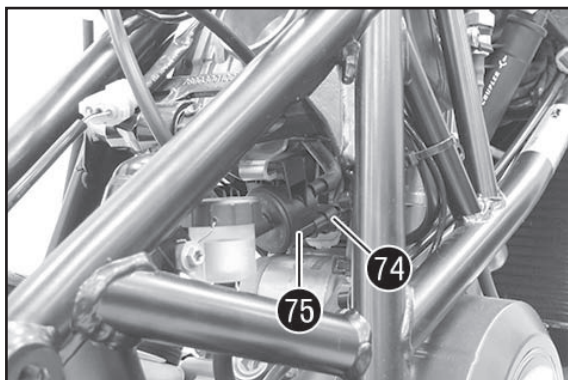

- Mettre en place la vis avec la bague d'étanchéité **11** (fournies) et serrer à 10 Nm (Loctite 243).

- Débrancher le connecteur **74**, poser le câble sans tension et le sécuriser au faisceau à l'aide d'un serre-câble.
- Retirer la soupape EVAP **75** de la tôle de fixation ainsi que les flexibles.

REMARQUE

La soupape EVAP ne doit pas être remontée.

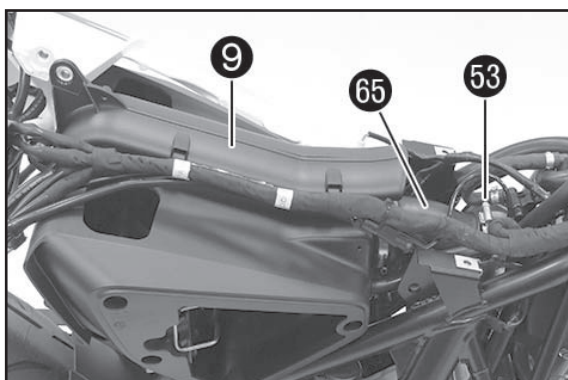

Monter le boîtier du filtre à air

- Mettre en place le boîtier du filtre à air **9** (fourni).
- Monter la trompette d'admission **65**.
- Positionner et serrer le collier **53**.

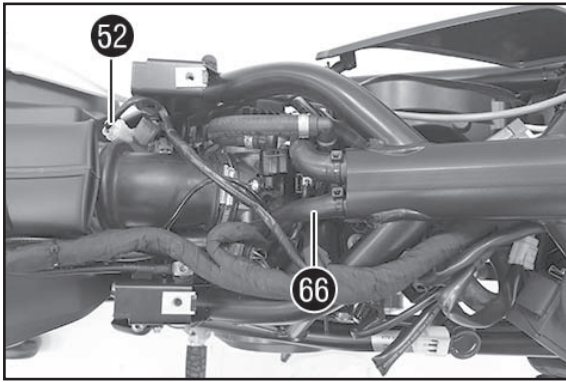

- Brancher le connecteur 52.
- Monter le tuyau de purge 66 et le fixer avec le serre-câble.

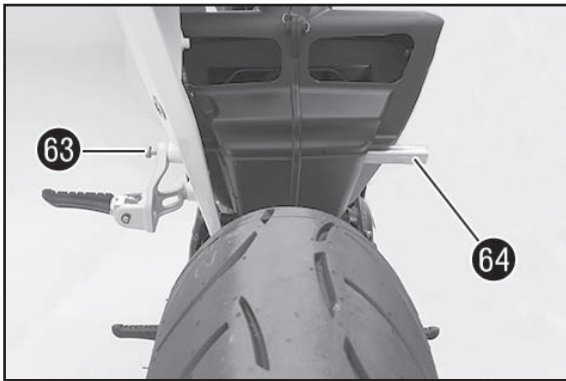

- Monter la douille d'origine 64.
- Monter la vis d'origine 63 sans la serrer.

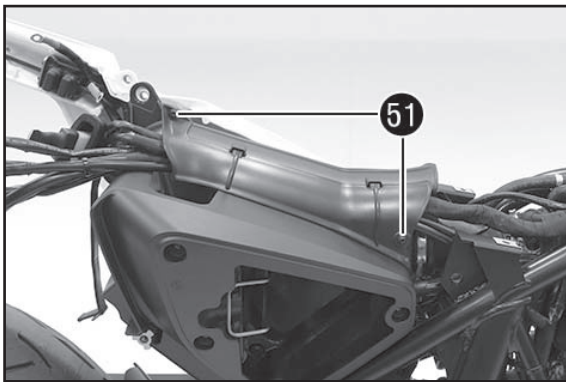

- Placer le cache câbles droit.
- Mettre les vis d'origine 51 en place et les serrer.

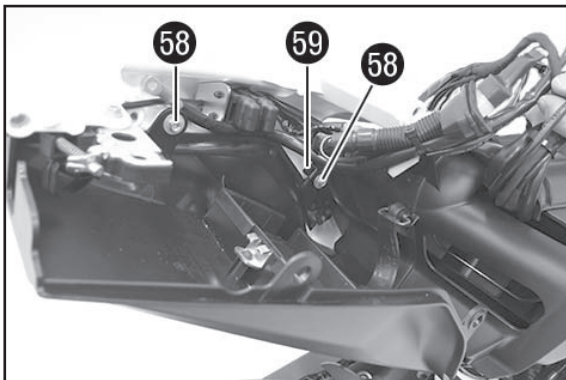

- Posizionare il supporto batteria.
- Posizionare il supporto per il comando a cavo flessibile della serratura della sella 59 e agganciare il comando a cavo flessibile.

AVVERTENZA

Il supporto per il comando a cavo flessibile viene posizionato nella parte anteriore.

- Montare le viti originali 58 e serrarle a 10 Nm.



- Montare il tappo originale 55.

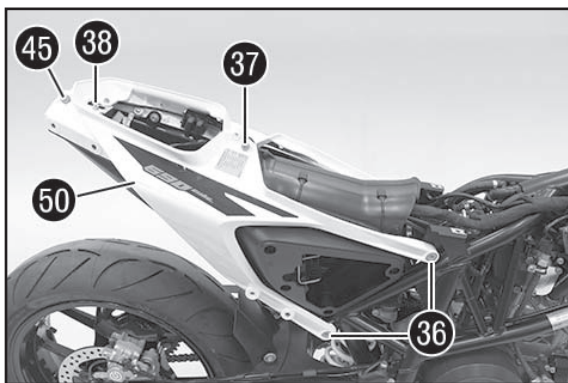

- Mettre en place le carénage arrière droit 50.
- Mettre en place les vis d'origine 36, 37, 38 mais sans les serrer.
- Mettre la vis d'origine 45 en place et la serrer à 25 Nm (Loctite 243).
- Serrer les vis 36 à 45 Nm.
- Serrer la vis 37 à 25 Nm (Loctite 243).
- Serrer la vis 38 à 10 Nm (Loctite 243).

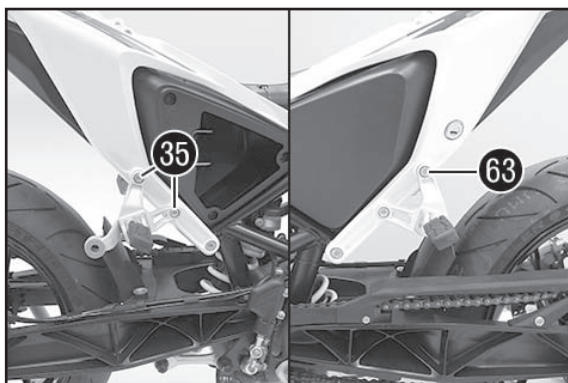

- Mettre en place le kit repose-pied passager.
- Mettre les vis d'origine 35 en place et les serrer à 25 Nm (Loctite 243).
- Mettre la vis d'origine 63 en place et la serrer à 25 Nm (Loctite 243).

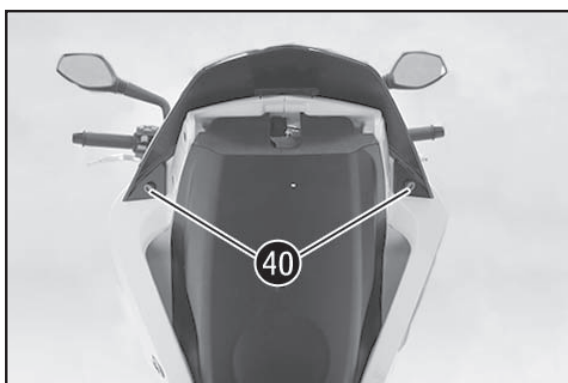

- Mettre en place le capot arrière.
- Mettre les vis d'origine 40 en place et les serrer à 10 Nm.

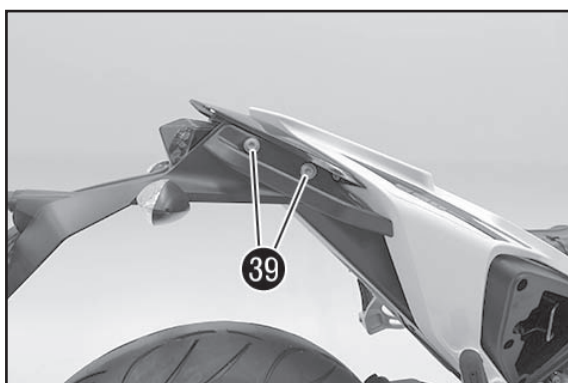

- Enfiler le câble et mettre en place le support de plaque d'immatriculation.
- Placer les poignées de maintien.
- Mettre les vis d'origine 39 en place et les serrer à 18 Nm (Loctite 243).

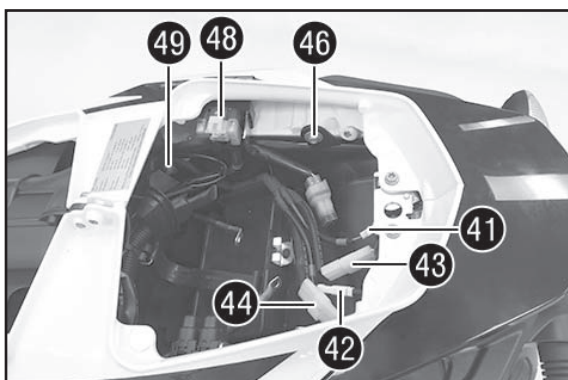

- Brancher le connecteur 41.
- Brancher le connecteur 42.
- Brancher le connecteur 43.
- Brancher le connecteur 44.
- Mettre la vis d'origine 46 en place et la serrer à 10 Nm.
- Mettre la vis d'origine 49 en place et la serrer à 10 Nm.
- Monter le relais de démarrage 46 sur la tôle de fixation.

! ATTENTION

Poser correctement tous les câbles et les fixer avec un serre-câble, le cas échéant. S'assurer que le câble n'est pas plié ni coincé !

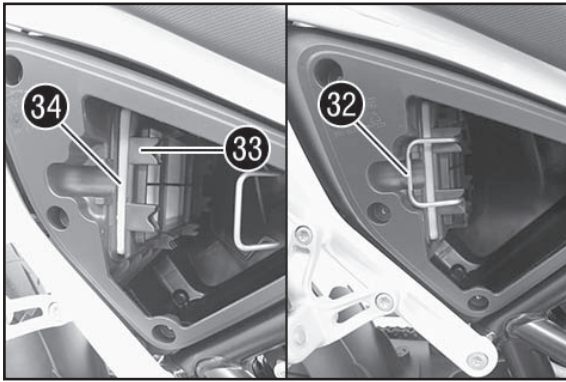

- Mettre en place le filtre à air 34 et le corps de filtre 33.
- Mettre en place et accrocher l'étrier de maintien du filtre à air 32.

REMARQUE

L'étrier de fixation doit venir s'emboîter sur tout son pourtour dans les encoches du corps de filtre.

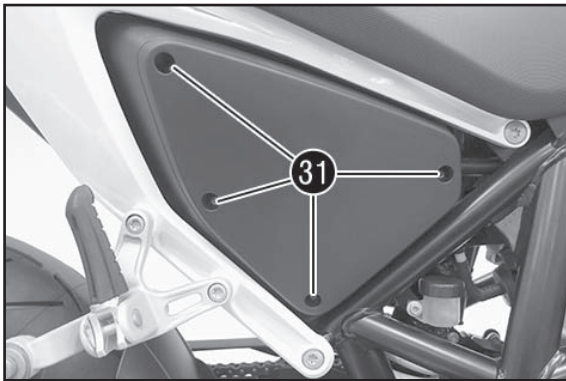

- Poser le couvercle du boîtier de filtre à air.
- Mettre les vis d'origine 31 en place et les serrer à 3 Nm.

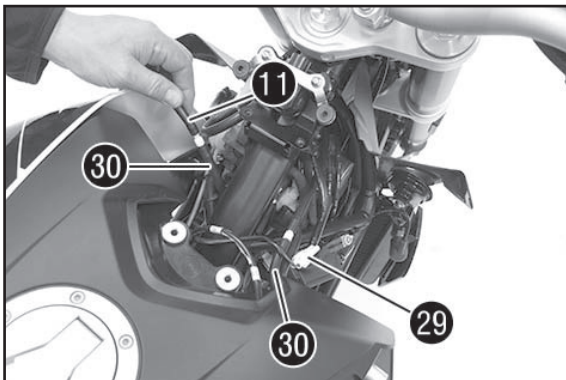

Monter le réservoir.

- Soulever le réservoir.
- Brancher le connecteur 29.
- Monter le tuyau de purge 30.
- Faire passer le tuyau de purge 30 de l'autre côté.
- Monter le tuyau de purge 11 (fourni).

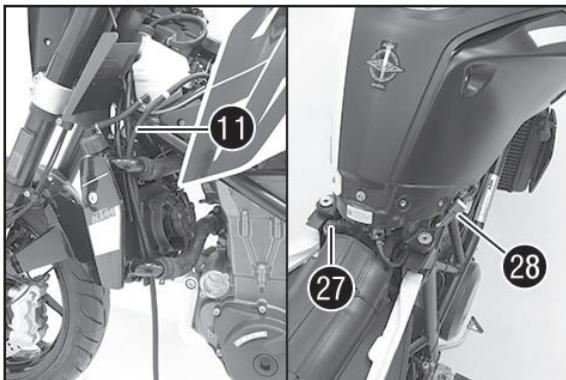

- Poser le tuyau de purge 11 sans tension vers le bas.

REMARQUE

Si le tuyau est trop long, il doit être raccourci.

- Mettre le réservoir en place.
- Enfiler le raccord de durite de carburant 27 et un joint torique neuf.
- Brancher le connecteur 23.



- Mettre les vis d'origine 26 en place et les serrer à 10 Nm.

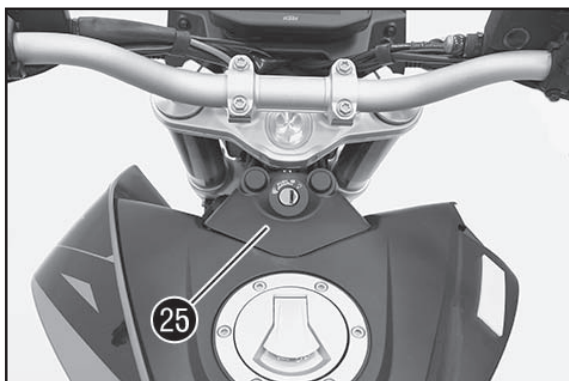

- Monter le carénage 25.

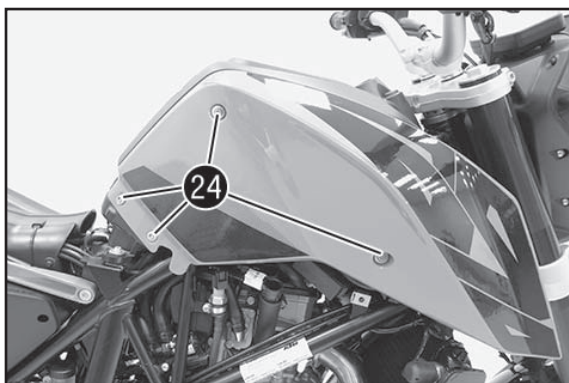

- Mettre en place le déflecteur.
- Mettre les vis d'origine 24 en place et les serrer à 3 Nm.

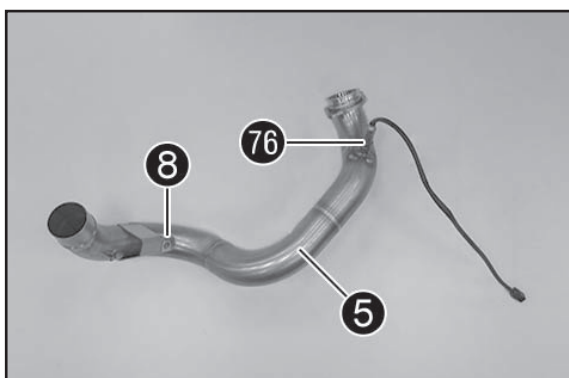

Pré-montage du collecteur

- Démonter la sonde lambda 76 du collecteur d'origine et le remonter sur le nouveau collecteur 5 (fourni).
- Installer les écrous multifonctions 8 (fournis).

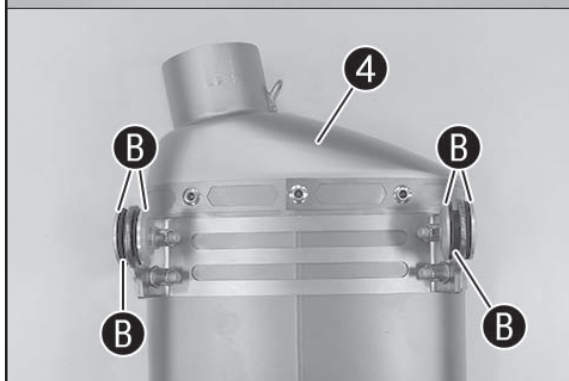

- Monter les douilles caoutchouc (fournies avec le kit de montage B) sur le support du pré-silencieux avant 4 (fourni).
- Monter les douilles argentées (fournies avec le kit de montage B) à gauche et à droite sur des douilles caoutchouc.

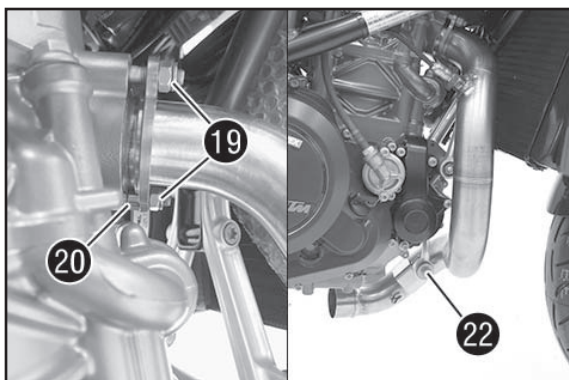

Monter l'échappement

- Mettre en place le collecteur 5 (fourni) avec le joint.
- Monter les écrous d'origine 19 avec la douille-entretoise 20, mais sans les serrer.
- Mettre en place la vis d'origine 22 avec la rondelle, sans la serrer.

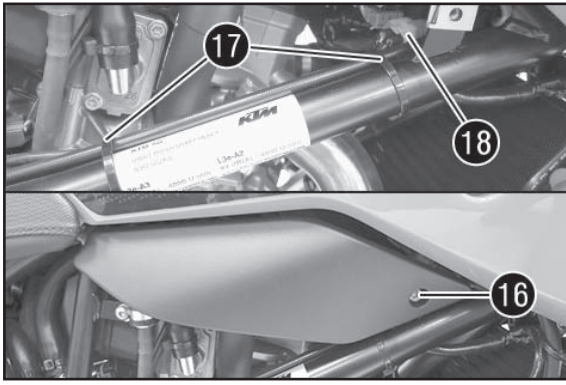

- Brancher le connecteur 18 de la sonde lambda. Sécuriser le câble à l'aide de serre-câbles 17.
- Retirer les carénages droit et gauche.
- Mettre les vis d'origine 18 en place des deux côtés et les serrer à 3 Nm.

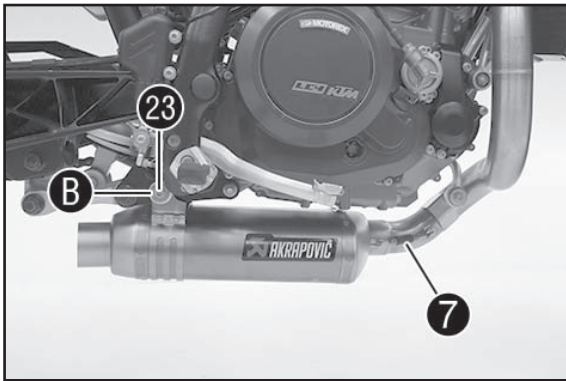

- Mettre en place le pré-silencieux avant 4 (fourni).
- Mettre les vis d'origine 23 en place avec les rondelles (fournies avec le kit de montage B) des deux côtés, mais sans les serrer.
- Monter le ressort d'échappement court 7 (fourni).

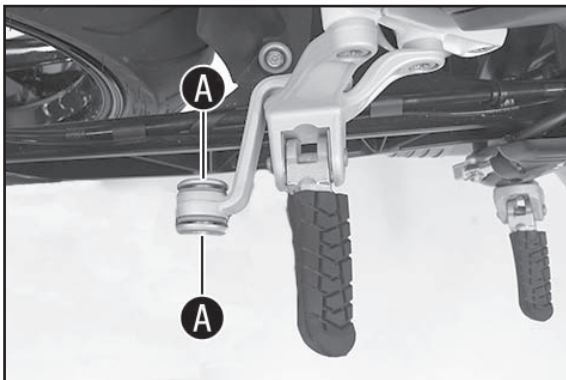

(Duke uniquement)

- Monter les douilles (livré avec le kit de montage A) sur les joints d'origine.

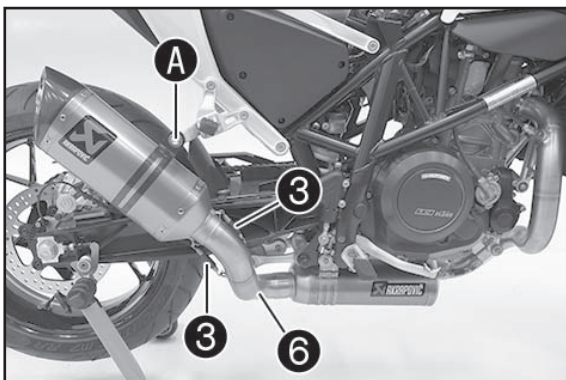

(Duke)

- Mettre en place le tube d'échappement 6 (fourni) sur le pré-silencieux avant.
- Mettre en place le silencieux arrière 1 (fourni) avec le collier d'échappement 2 (fourni).
- Mettre la vis (fournie avec le kit de montage A) en place avec la rondelle d'origine et l'écrou avec la rondelle (toutes deux fournies avec le kit de montage A) et serrer à 15 Nm.
- Accrocher les ressorts d'échappement longs 3 (fournis).

(Duke R)

- Mettre en place le tube d'échappement 6 (fourni) sur le pré-silencieux avant.
- Monter le silencieux arrière d'origine avec le collier d'échappement.
- Mettre la vis d'origine 15 en place avec la rondelle et la serrer à 15 Nm.
- Accrocher les ressorts d'échappement longs 3 (fournis).

(Duke uniquement)

- Accrocher le ressort d'échappement court 7 (fourni).

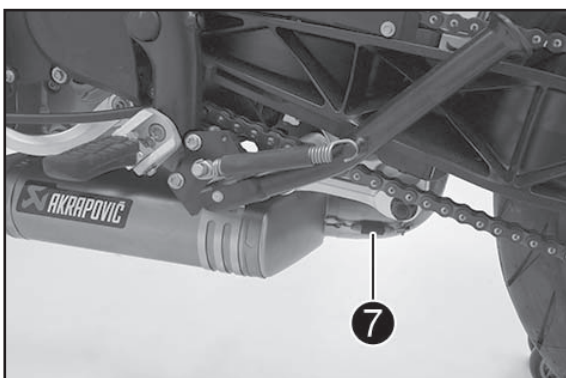

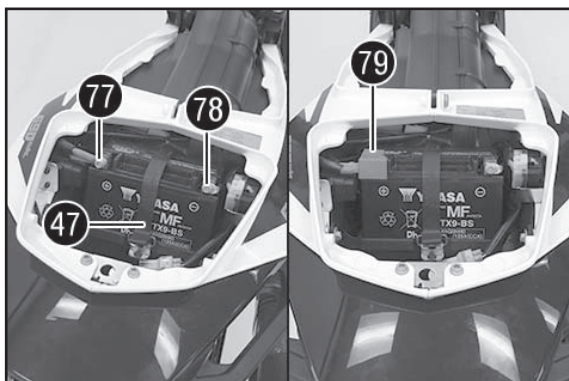

Poser la batterie

- Placer la batterie dans le support de la batterie.
- ✓ Les pôles de la batterie sont orientés dans le sens inverse de la marche.
- Accrocher le caoutchouc de maintien 47.
- Raccorder les deux câbles positifs 77 à la batterie et serrer la vis à 2 Nm.
- Raccorder le câble négatif 78 à la batterie et serrer la vis à 2 Nm.
- Monter le couvercle du pôle positif 79.

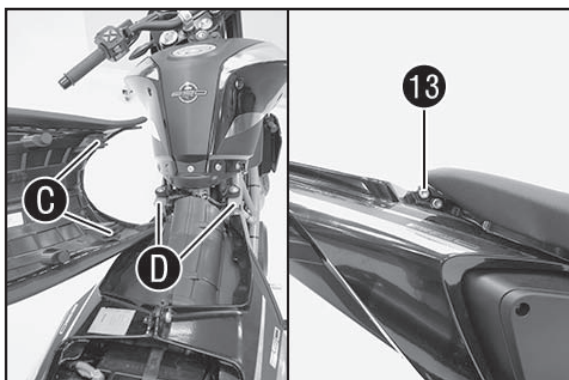

Monter la selle du pilote

- Glisser la selle vers l'avant en l'abaissant vers l'arrière.
- ✓ Les ergots C s'enclenchent dans les attaches D du cadre.
- Mettre la vis 13 en place et la serrer à 25 Nm.
- Contrôler ensuite que la selle du pilote est bien en place.

Travaux ultérieurs

- Monter la selle passager (voir le manuel d'utilisation).
- Déposer la moto du dispositif de levage arrière (voir manuel d'utilisation).



! ATTENTION

Lors de la première utilisation du silencieux arrière, laisser tourner le moteur au ralenti pendant 5 minutes environ pour réchauffer le silencieux arrière uniformément. Cette précaution est nécessaire pour que la laine de roche atteigne son degré d'efficacité maximal et que les niveaux d'émission sonore prescrits soient respectés !

Montage final

S'assurer que l'échappement ne touche aucune autre pièce de la moto.
 Enlever les résidus de graisse à l'aide d'un chiffon doux imbibé de lubrifiant multi-usage (Motorex Joker 440).
 Le nettoyage évite que des tâches ne s'incruster sur la surface sous l'effet de la chaleur. Ne pas utiliser de nettoyeurs chimiques agressifs car ils risquent d'endommager les autocollants.
 S'assurer que toutes les vis sont serrées. Si l'échappement touche le carénage ou d'autres pièces, répéter l'ajustement ou contacter le concessionnaire !
 L'émission de fumées blanches par le silencieux est normale lors de la première mise en service de l'échappement !
 Vérifier ensuite l'étanchéité de l'échappement.
 Ne pas rester derrière l'échappement lors de la première mise en service !

Entretien de l'échappement

Nettoyer avec un spray lubrifiant universel (Motorex Joker 440).
 Un changement de couleur de l'échappement est normal en raison de la température élevée.
 L'usure de la laine de roche du silencieux dépend du type de moteur et du style de conduite. S'adresser au concessionnaire en cas de changements visibles sur l'enveloppe extérieure du silencieux ou d'augmentation des émissions sonores.
 Vérifier régulièrement que toutes les vis sont suffisamment serrées et que les ressorts sont bien en place.

Pièces détachées

Kit isolant	76005979010
Laine isolante	
14x rivets D4,8x8	
2x rivets D4,8x12	
Kit de réparation	76005979220
1x enveloppe extérieure en titane	
2x couloirs à rivets en titane	
14x rivets D4,8x8	
2x rivets D4,8x12	
1x autocollant	
1x autocollant avec le numéro de brevet	

1x collier d'échappement en carbone ②	76005979001
1x embout de protection en carbone ⑧⑩	76005979005
2x ressorts d'échappement longs ③	57305016000

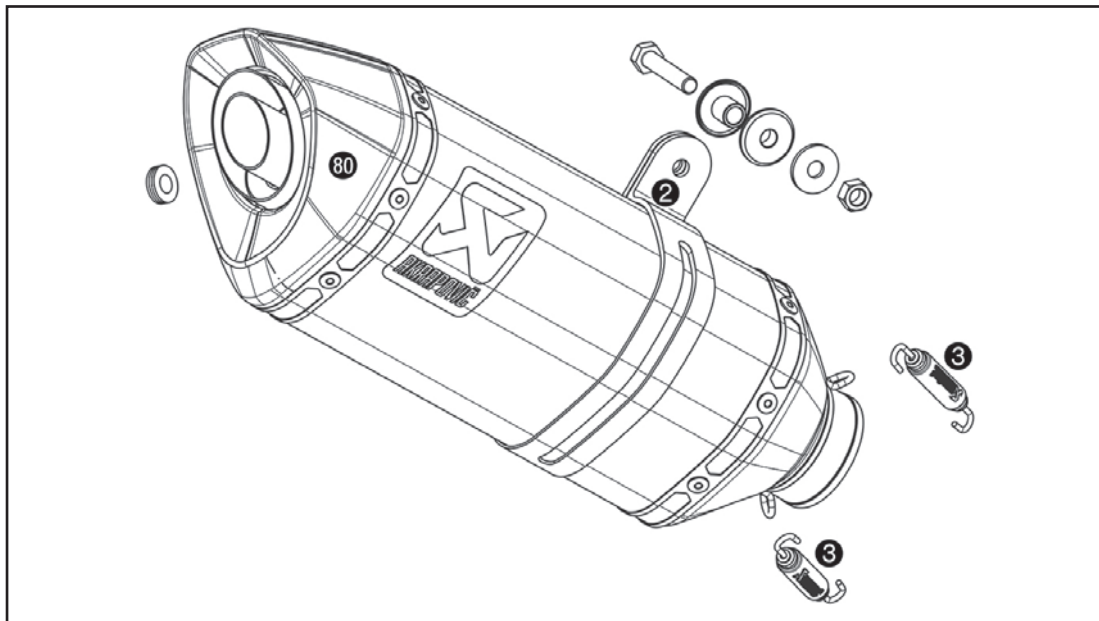

Pièces détachées

1x autocollant Akrapovic ⑧③	60005099003
-----------------------------	-------------

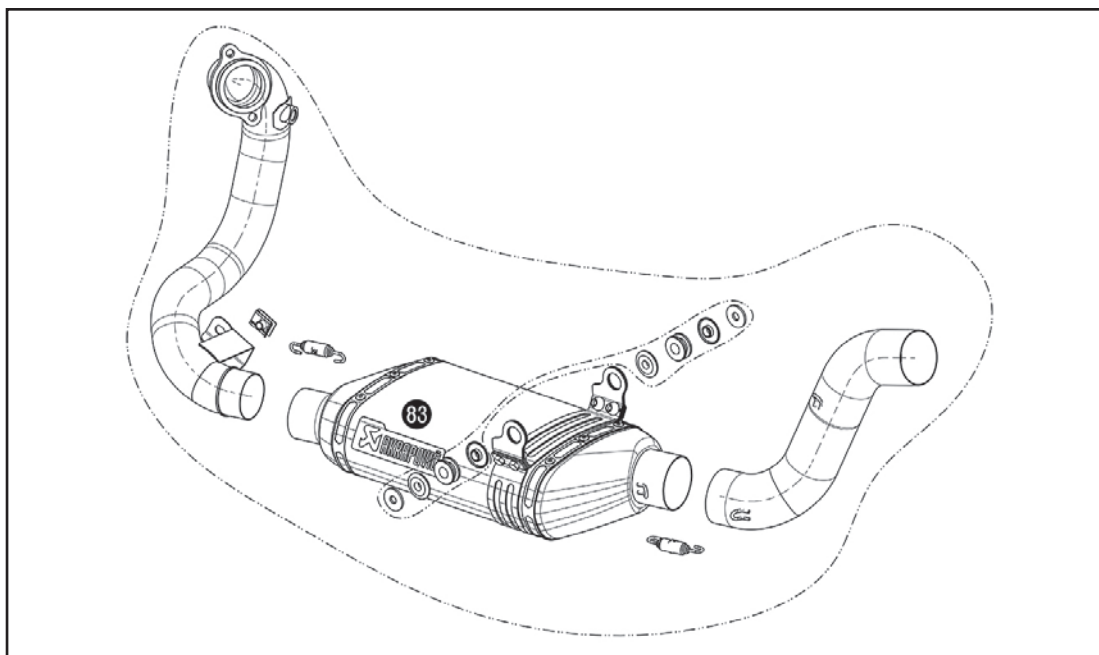

Le recomendamos que instale el kit de tuning únicamente en talleres especializados y autorizados o que encargue su instalación a un técnico de servicio posventa debidamente cualificado. ¡Si se montan incorrectamente los componentes, puede reducirse la durabilidad y pueden producirse daños en la motocicleta!

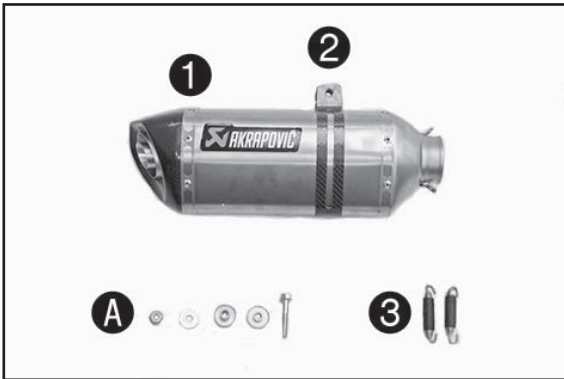

Volumen de suministro 76612945000 (solo 690 Duke)

- 1x silenciador AKRAPOVIC ① 76005979200
- 1x abrazadera del tubo de escape de carbono ②
- 2x muelles largos para el tubo de escape ③
- 1x kit de montaje ④

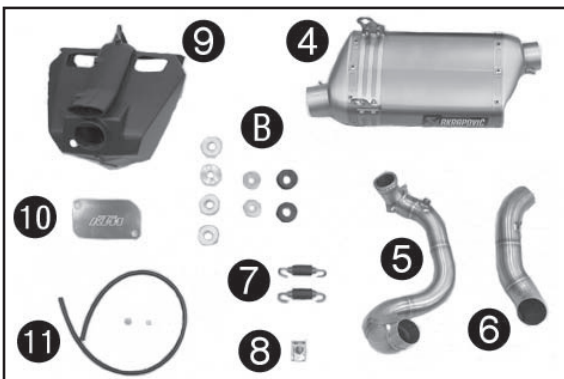

Volumen de suministro 76612945000 y 76612945100

- Juego del colector AKRAPOVIC EVO 76005907100
- 1x presilenciador ④
- 1x colector ⑤
- 1x tubo del colector ⑥
- 2x muelles cortos para el tubo de escape ⑦
- 1x tuerca capa chapa ⑧
- 1x kit de montaje ⑨
- 1x caja del filtro de aire de tuning ⑨ 76006901000
- 1x tapa de cierre SLS ⑩ 60005022200
- 1x kit de desmontaje EVAP ⑪ 76015999044



⚠ ATENCION

¡Este kit de tuning no cuenta con homologación para circular por la vía pública!

La instalación solo puede montarse y operarse en combinación con el mapping EFI especial de AKRAPOVIC. El mapping debe instalarse en su concesionario antes de utilizarse por primera vez.

- Mapping EFI de AKRAPOVIC (690 Duke) 76641033131
- Mapping EFI de AKRAPOVIC (690 Duke R) 76641033132

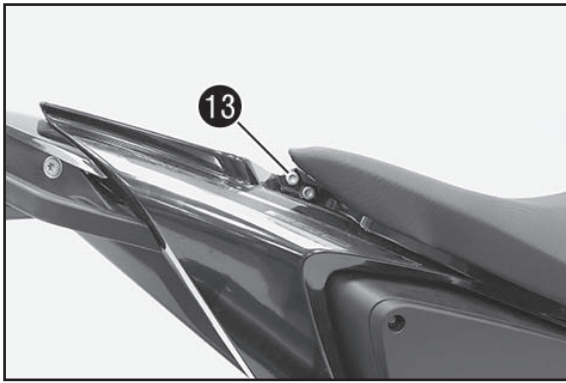

Trabajos previos

- Levantar la parte trasera de la motocicleta con el soporte de elevación (véase el manual de instrucciones).
- Quitar el asiento del acompañante (véase el manual de instrucciones).
- Desembornar la batería (véase el manual de instrucciones).

Desmontar el asiento del conductor

- Retirar el tornillo 13.
- Levantar la parte trasera del asiento, tirar de él hacia atrás y desmontarlo a continuación hacia arriba.

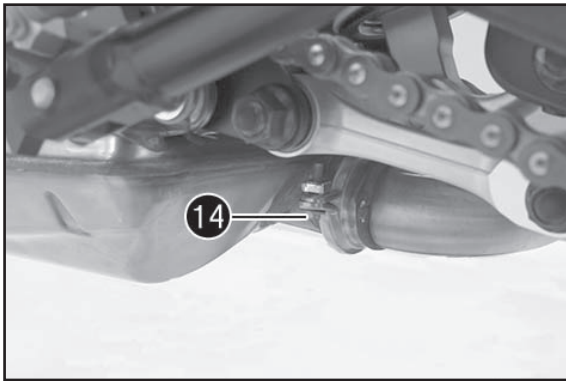

Desmontar el silenciador

Advertencia
Peligro de quemaduras

El equipo de escape alcanza temperaturas muy elevadas durante el funcionamiento del vehículo.

- Dejar enfriar el equipo de escape. No tocar las piezas calientes.

- Retirar el tornillo 14. Retirar la abrazadera del silenciador.

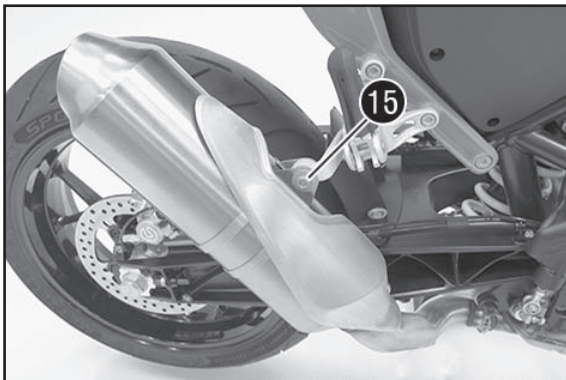

(Duke)

- Retirar el tornillo 15 con la arandela.
- Retirar el silenciador.

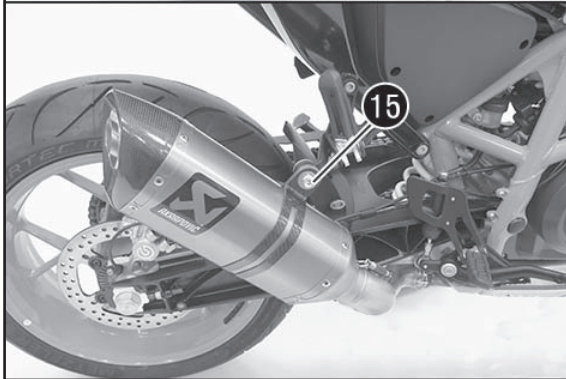

(Duke R)

- Retirar el tornillo 15 con la arandela.
- Retirar el silenciador.

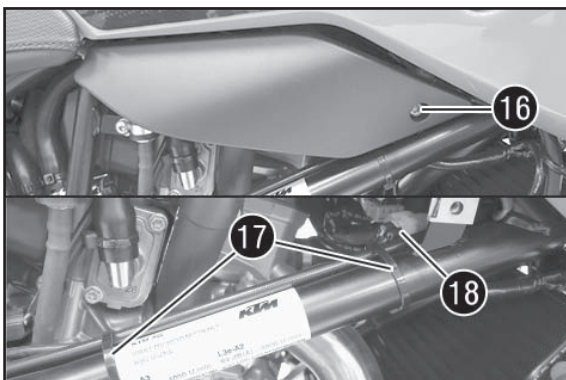

Desmontar el sistema de escape

- Retirar el tornillo 16 a ambos lados. Retirar el carenado derecho e izquierdo.
- Retirar las cintas sujetacables 17. Desenchufar el conector 18 de la sonda lambda.

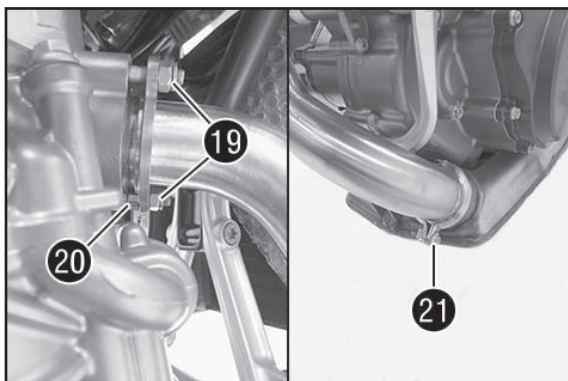

- Retirar las tuercas 19.

AVISO

Tener cuidado para no perder el casquillo distanciador 20.

- Retirar los tornillos 21. Quitar la abrazadera.
- Retirar el colector y la junta.



- Retirar el tornillo 22 con la arandela.
- Retirar los tornillos 23 a ambos lados.
- Quitar el presilenciador.

Desmontar el depósito



Peligro

Peligro de incendio El combustible es fácilmente inflamable

- No repostar el vehículo en la cercanía de llamas abiertas o de cigarrillos encendidos y parar siempre el motor para repostar. Asegurarse de que el combustible no puede derramarse sobre las piezas calientes del vehículo. Limpiar inmediatamente cualquier derrame de combustible.
- El combustible que hay en el interior del depósito se dilata cuando se calienta, por lo que podría salirse si se llena excesivamente. Observar las instrucciones de repostaje.



Advertencia

Peligro de envenenamiento El combustible es tóxico y perjudicial para la salud

- Evitar que el combustible entre en contacto con la piel, los ojos o la ropa. No inhalar los vapores del combustible. En caso de contacto con los ojos, lavar inmediatamente con agua y buscar ayuda médica. Limpiar inmediatamente con agua y jabón las partes de la piel contaminadas. En caso de ingestión del combustible, buscar ayuda médica inmediatamente. Cambiarse la ropa que esté sucia de combustible. Guardar el combustible correctamente en un recipiente adecuado y mantenerlo fuera del alcance de los niños.

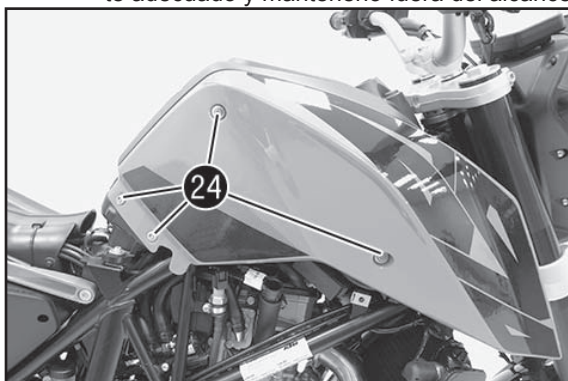

- Retirar los tornillos 24.
- Retirar el spoiler derecho.

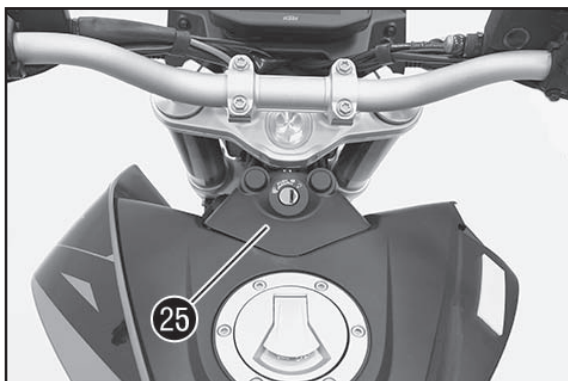

- Tirar del carenado 25 hacia arriba y retirarlo.

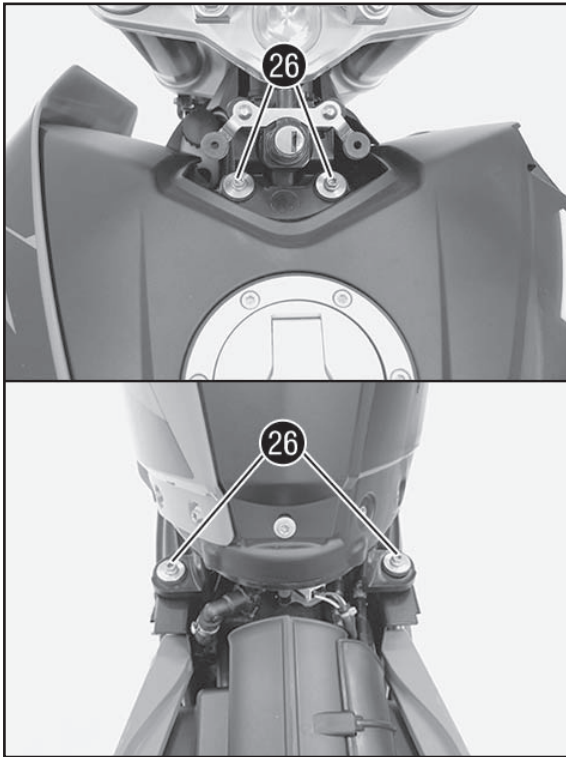

- Retirar los tornillos 26.

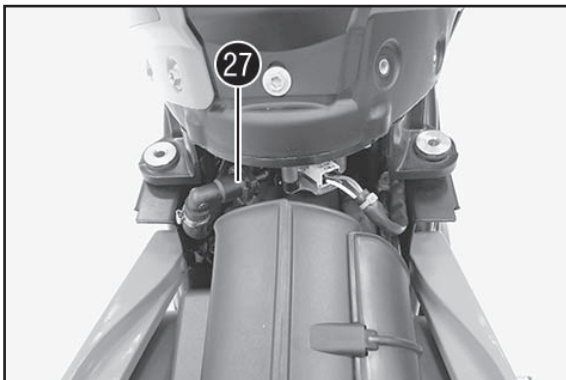

- Desconectar el empalme de la manguera de combustible 27.

AVISO

Es posible que salgan restos de combustible por la manguera de combustible.

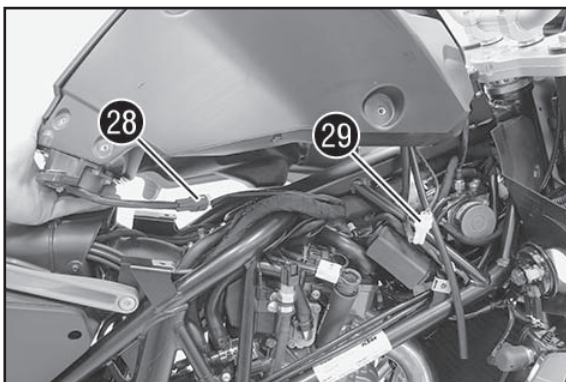

- Levantar el depósito de combustible.
- Separar el conector 28.
- Separar el conector 29.

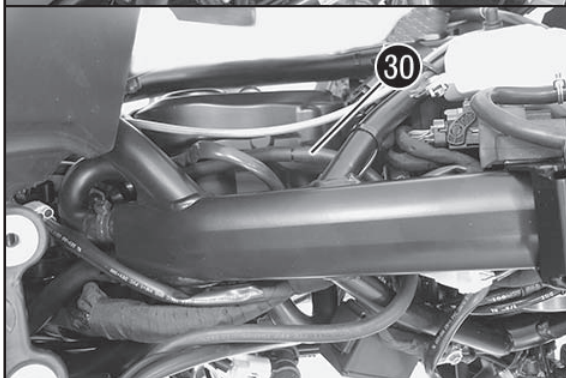

(Duke)

- Quitar la manguera del respiradero 30.
- Quitar el depósito de combustible.

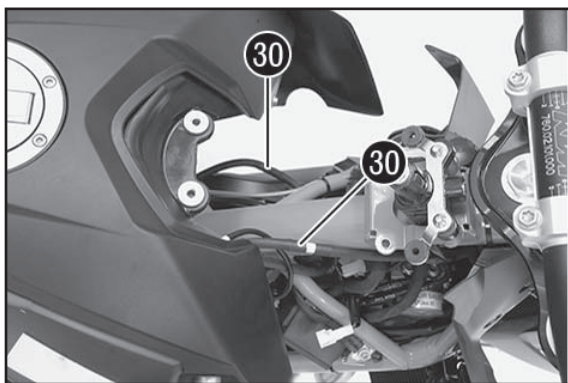

(Duke R)

- Quitar las mangueras del respiradero 30.
- Quitar el depósito de combustible.

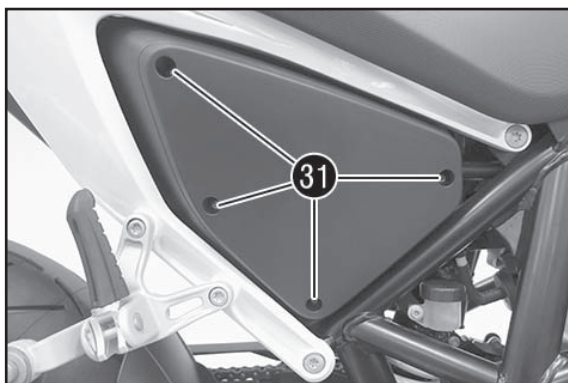

Desmontar la caja del filtro de aire

- Retirar los tornillos 31.
- Extraer la tapa de la caja del filtro de aire.

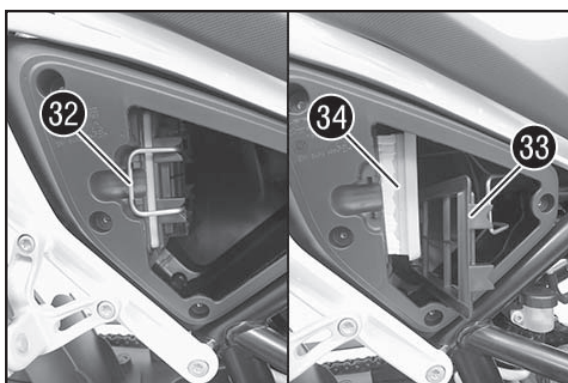

- Desenganchar el estribo de sujeción del filtro de aire 32 y bascularlo hacia un lado.

- Retirar el marco del filtro 33 y el filtro de aire 34.

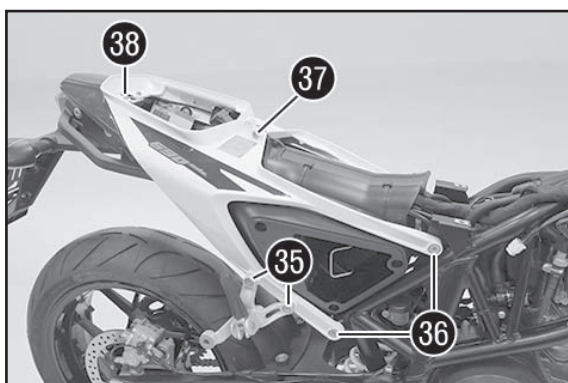

- Retirar los tornillos 35.
- Retirar el soporte del reposapiés del acompañante.
- Retirar los tornillos 36.
- Retirar el tornillo 37.
- Retirar el tornillo 38.

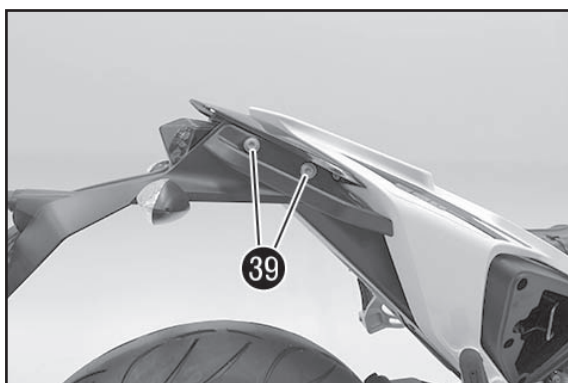

- Retirar los tornillos 39 a ambos lados.
- Quitar los asideros.

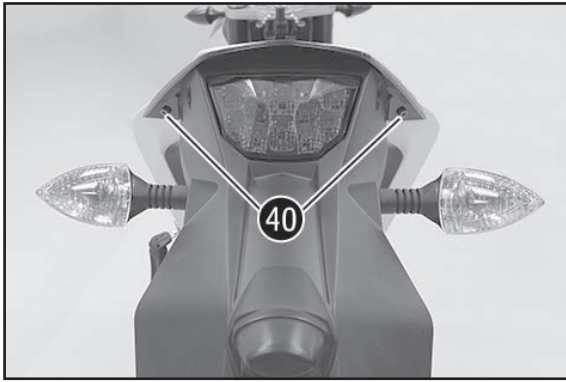

- Retirar los tornillos 40.
- Retirar la cubierta trasera.

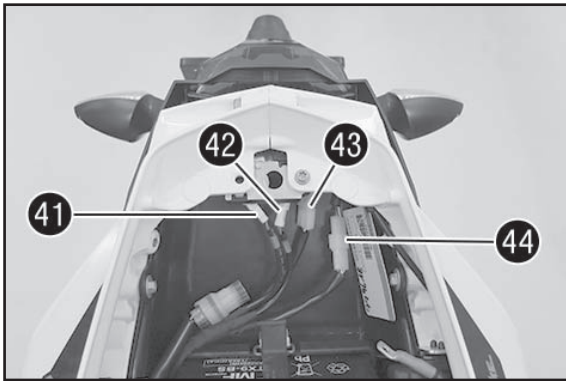

- Separar el conector 41.
- Separar el conector 42.
- Separar el conector 43.
- Separar el conector 44.
- Extraer el cable y quitar el soporte de la placa de matrícula.

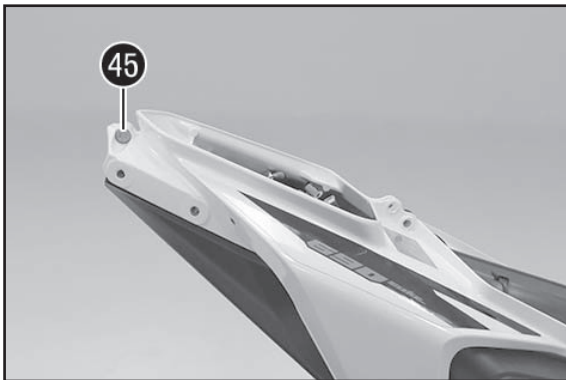

- Retirar el tornillo 45.

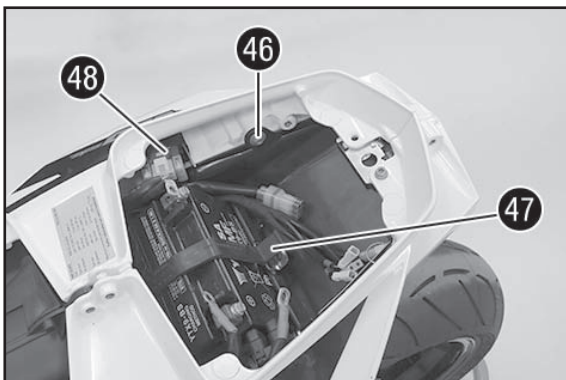

- Retirar el tornillo 46.
- Descolgar la goma de sujeción 47.
- Retirar la batería de su soporte hacia arriba.
- Retirar el relé de arranque 48 de la chapa de sujeción.

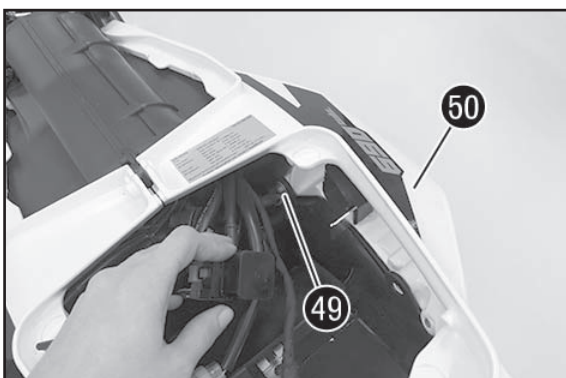

- Retirar el tornillo 49.
- Retirar la parte trasera derecha 50.

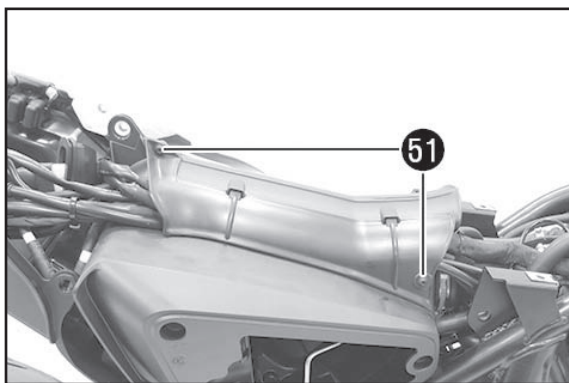

- Retirar los tornillos 51.
- Retirar la cubierta derecha de los cables.

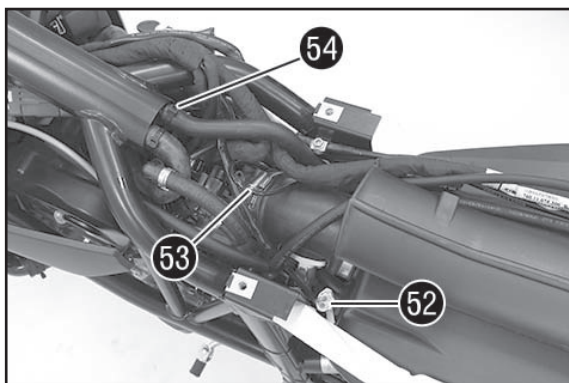

- Separar el conector 52.
- Soltar la abrazadera para mangueras 53.
- Retirar la cinta sujetacables 54.
- Quitar la manguera del respiradero.

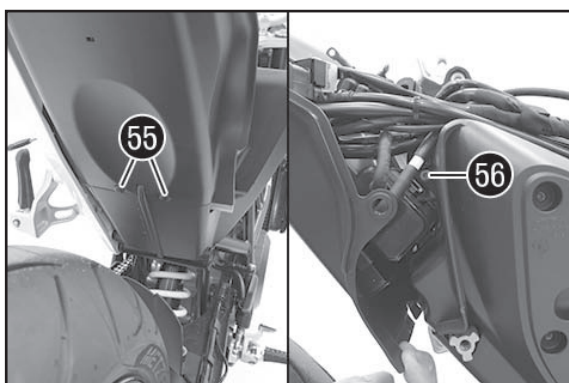

- Retirar el tapón 55.
- Retirar el tornillo 56.

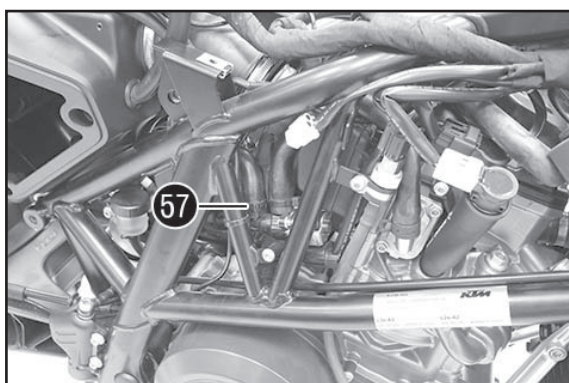

- Retirar la cinta sujetacables 57.
- Quitar la manguera del sistema de aire secundario.

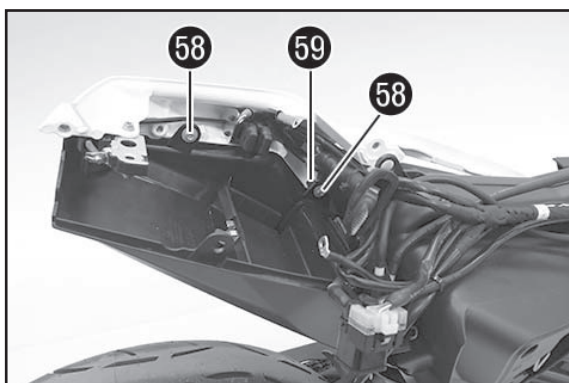

- Retirar los tornillos 58.
- Retirar el soporte del cable de tracción del cierre del asiento 59.
- Desmontar el soporte de la batería.

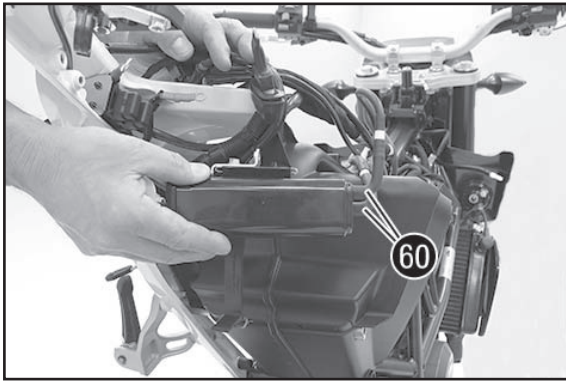

- Quitar las mangueras 60.
- Retirar el filtro de carbón activo.

AVISO

El filtro de carbón activo no vuelve a instalarse.

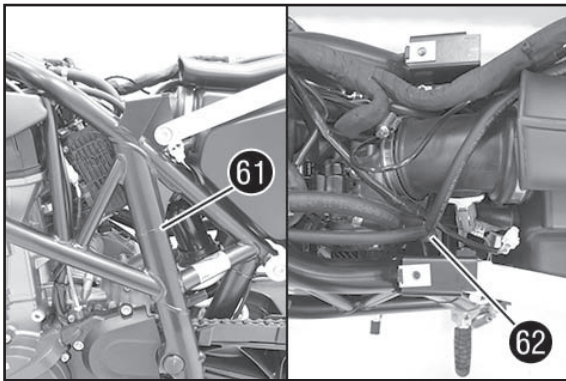

- Retirar la cinta sujetacables 61.
- Retirar la pieza en forma de Y 62 con las mangueras.

AVISO

Las mangueras no se vuelven a montar.

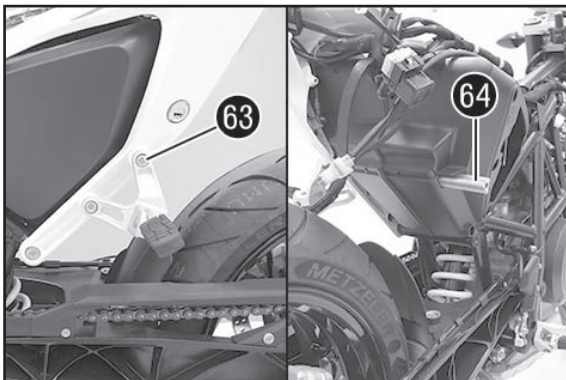

- Retirar el tornillo 63.
- Retirar el manguito 64 hacia la derecha.

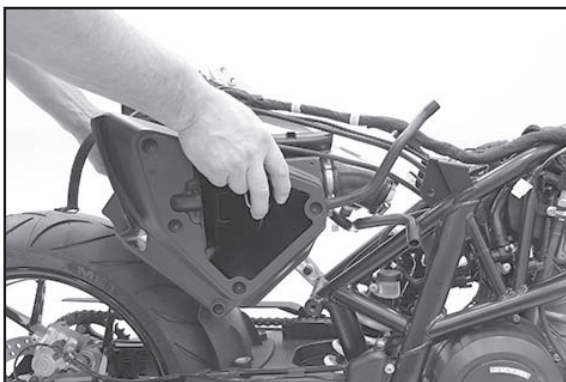

- Retirar la caja del filtro de aire.

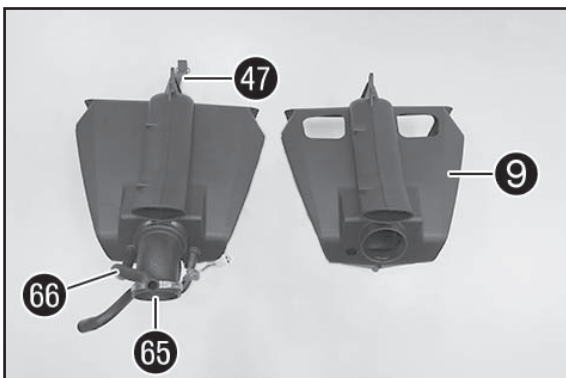

Tareas previas de montaje de la caja de filtro de aire

- Desmontar la goma de sujeción, 47, el embudo de aspiración 65 con la abrazadera para mangueras y la manguera del respiradero 66 de la caja del filtro de aire original y montar estos componentes en la caja del filtro de aire 9 (volumen de suministro).

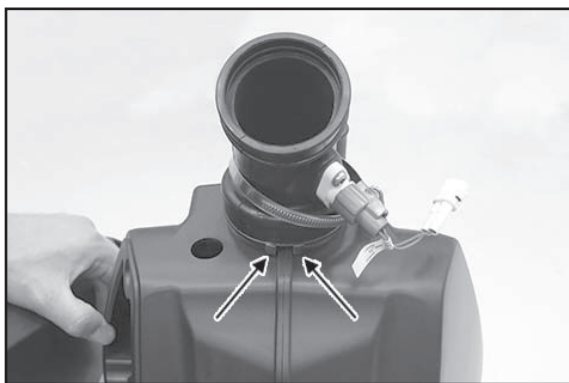

AVISO

Montar el embudo de aspiración como se muestra en la ilustración.

- ✓ Los talones de sujeción posicionan el embudo de aspiración en la barra (véase la flecha).

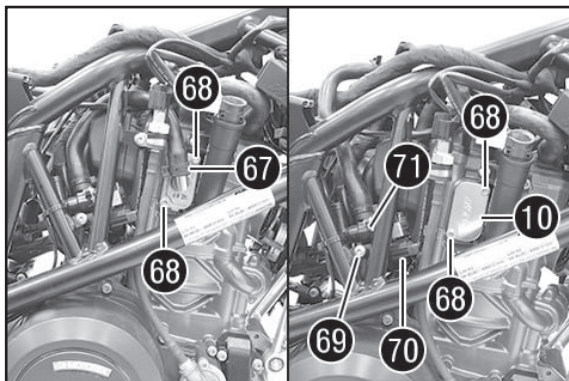

Desmontaje del sistema de aire secundario

- Soltar la abrazadera de fleje de acero 67 y retirar la manguera del sistema de aire secundario.
- Retirar los tornillos 68.
- Desmontar la tapa.
- Colocar la tapa del sistema de aire secundario 10 (volumen de suministro).
- Montar los tornillos originales 68 y apretarlos a 10 Nm.
- Retirar el tornillo 69.
- Extraer el conector 70, tender el cable sin tensión y asegurarlo al ramal de cables con cinta sujetacables.
- Retirar la válvula del sistema de aire secundario 71 con la manguera.

AVISO

La válvula del sistema de aire secundario no vuelve a montarse.

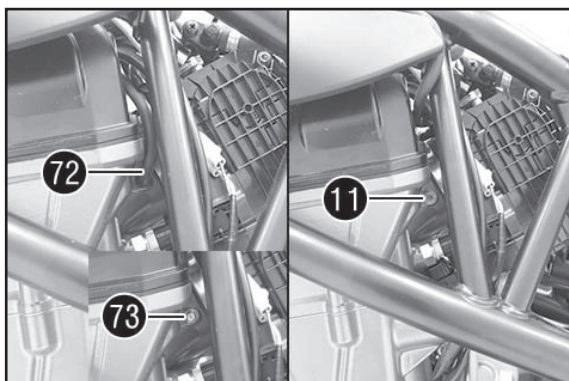

Kit de desmontaje EVAP

- Retirar la manguera 72 en el lado izquierdo.
- Retirar la válvula 73.

AVISO

La manguera y la válvula no se vuelven a montar.

- Montar el tornillo y el anillo de hermetizado 11 (ambos en el volumen de suministro) y apretarlo a 10 Nm (Loctite 243).

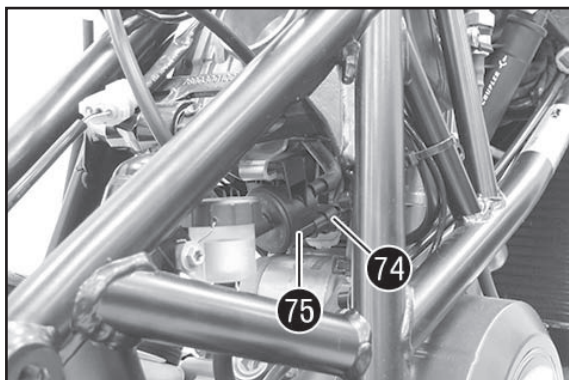

- Extraer el conector 74, tender el cable sin tensión y asegurarlo al ramal de cables con cinta sujetacables.
- Quitar la válvula EVAP 75 de la chapa de sujeción y retirarla con las mangueras.

AVISO

La válvula EVAP no vuelve a montarse.

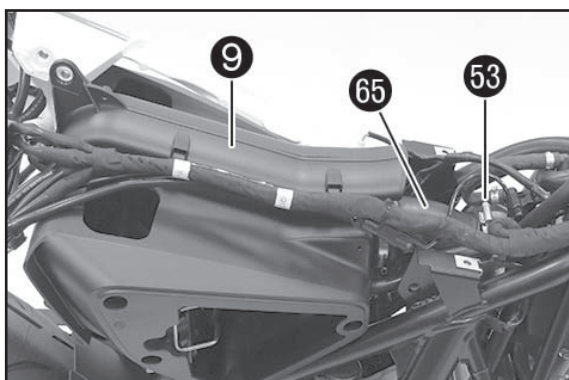

Montar la caja del filtro de aire

- Posicionar la caja de filtro de aire 9 (volumen de suministro).
- Montar el embudo de aspiración 65.
- Posicionar y apretar la abrazadera para mangueras 53.

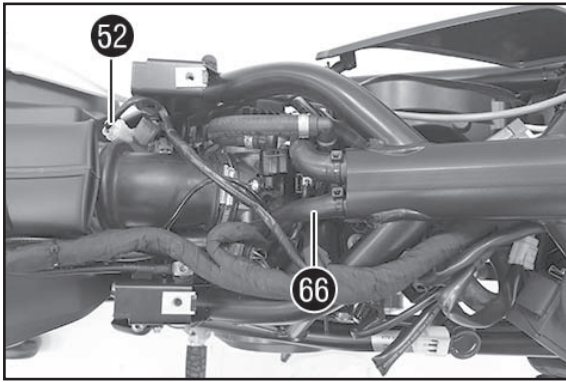

- Enchufar el conector 52.
- Montar la manguera del respiradero 66 y asegurarla con cinta sujetacables.

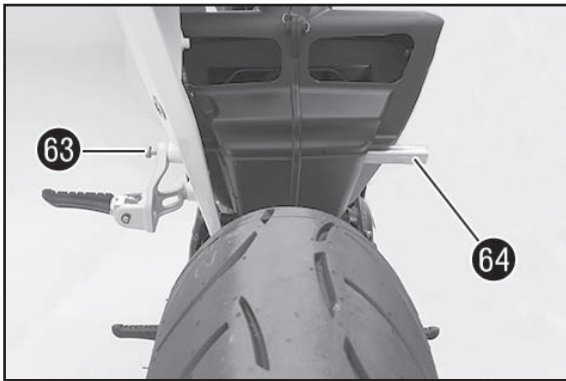

- Montar el manguito original 64.
- Montar el tornillo original 63, pero no apretarlo todavía.

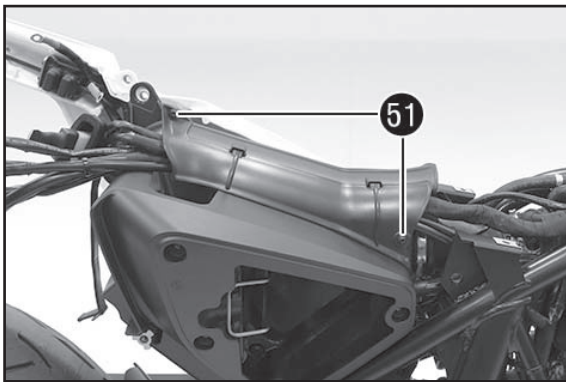

- Posicionar la cubierta derecha de los cables.
- Montar y apretar los tornillos originales 51.

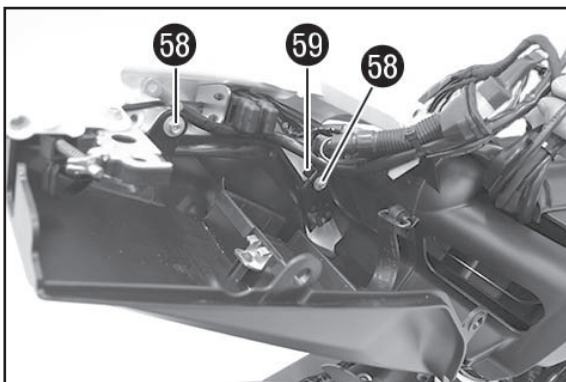

- Posicionar el soporte de la batería.
- Colocar el soporte del cable de tracción del cierre del asiento 59 y enganchar el cable de tracción.

AVISO
El soporte del cable de tracción se coloca delante.

- Montar los tornillos originales 58 y apretarlos a 10 Nm.



- Montar el tapón original 55.

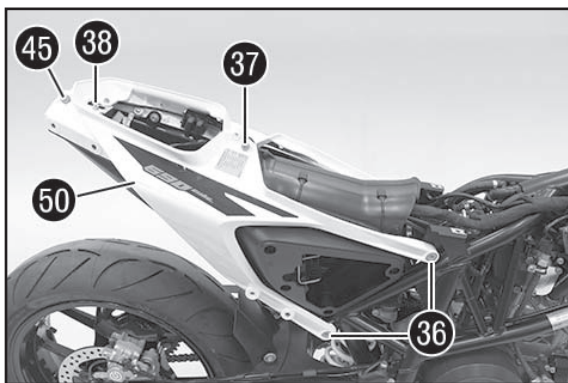

- Posicionar la parte trasera derecha 50.
- Montar los tornillos originales 36, 37, 38 pero no apretarlos todavía.
- Montar el tornillo original 45 y apretarlo a 25 Nm (Loctite 243).
- Apretar los tornillos 36 a 45 Nm.
- Apretar el tornillo 37 a 25 Nm (Loctite 243).
- Apretar el tornillo 38 a 10 Nm (Loctite 243).

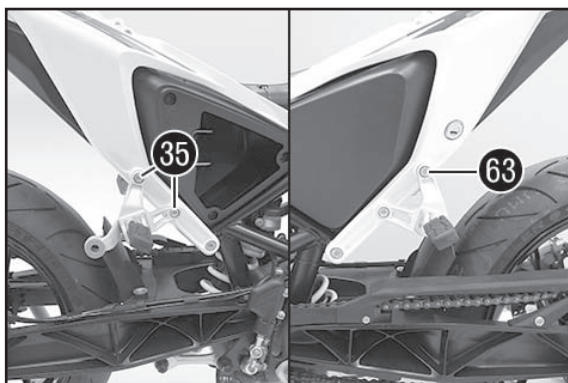

- Posicionar el soporte del reposapiés del acompañante.
- Montar los tornillos originales 35 y apretarlos a 25 Nm (Loctite 243).
- Montar el tornillo original 63 y apretarlo a 25 Nm (Loctite 243).

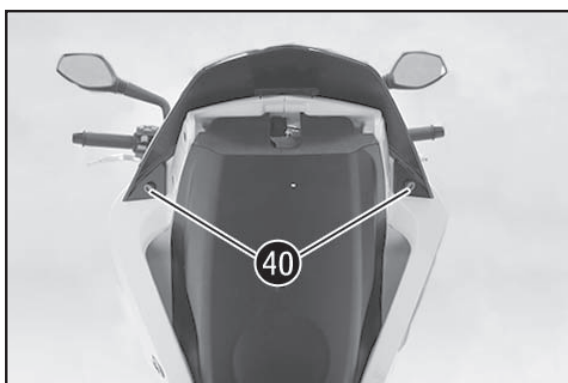

- Posicionar la cubierta trasera.
- Montar los tornillos originales 40 y apretarlos a 10 Nm.

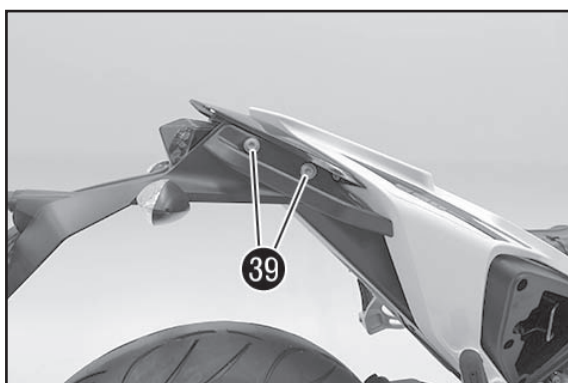

- Introducir el cable y posicionar el soporte de la placa de matrícula.
- Colocar los asideros.
- Montar los tornillos originales 39 y apretarlos a 18 Nm (Loctite 243).

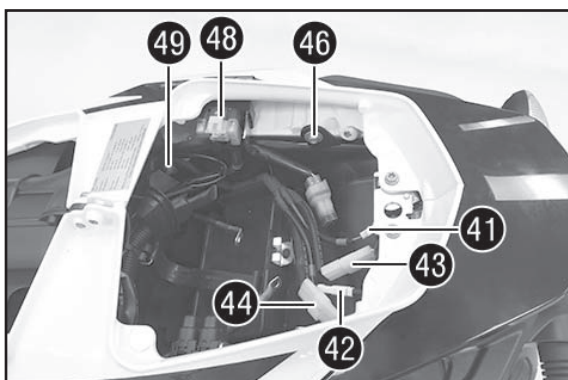

- Enchufar el conector 41.
- Enchufar el conector 42.
- Enchufar el conector 43.
- Enchufar el conector 44.
- Montar el tornillo original 46 y apretarlo a 10 Nm.
- Montar el tornillo original 49 y apretarlo a 10 Nm.
- Montar el relé de arranque 48 en la chapa de sujeción.

! AVISO

Tender todos los cables correctamente y, dado el caso, sujetarlos con cinta sujetacables. Asegurarse de que los cables no puedan retorcerse o quedar aprisionados!

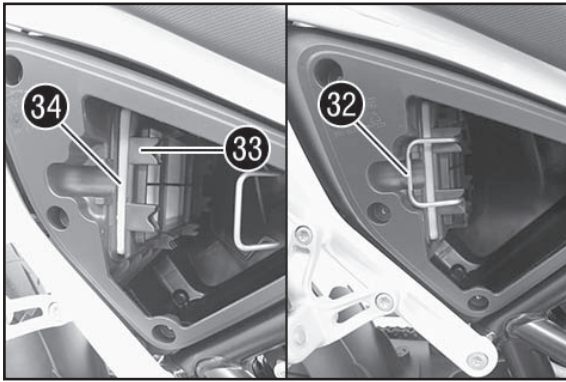

- Posicionar el filtro de aire 34 y el marco del filtro 33.
- Colocar y enganchar el estribo de sujeción del filtro de aire 32.

AVISO

El estribo de sujeción debe estar asentado en las escotaduras del marco del filtro en todo su perímetro.

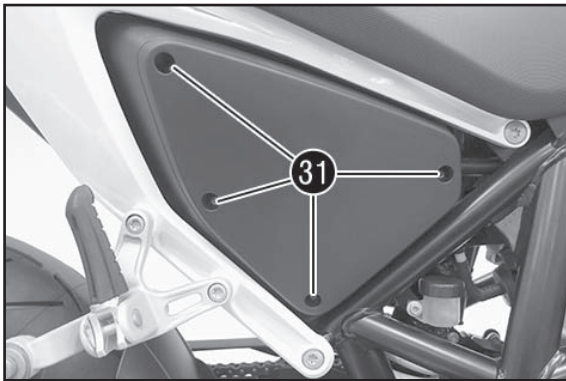

- Montar la tapa de la caja del filtro de aire.
- Montar los tornillos originales 31 y apretarlos a 3 Nm.

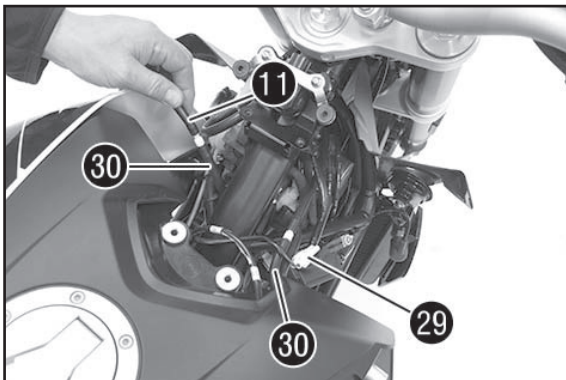

Montar el depósito

- Levantar el depósito.
- Enchufar el conector 29.
- Montar la manguera del respiradero 30.
- Llevar la manguera del respiradero 30 hacia el otro lado.
- Montar la manguera del respiradero 11 (volumen de suministro).

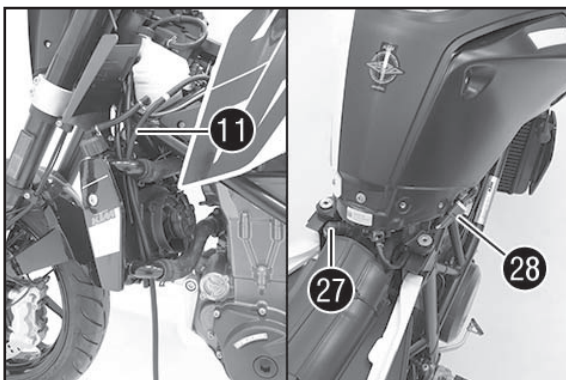

- Tender la manguera del respiradero 11 sin tensión hacia abajo.

AVISO

Si la manguera es demasiado larga, debe acortarse.

- Posicionar el depósito.
- Encajar el empalme de la manguera de combustible 27 utilizando una junta tórica nueva.
- Enchufar el conector 28.



- Montar los tornillos originales 26 y apretarlos a 10 Nm.

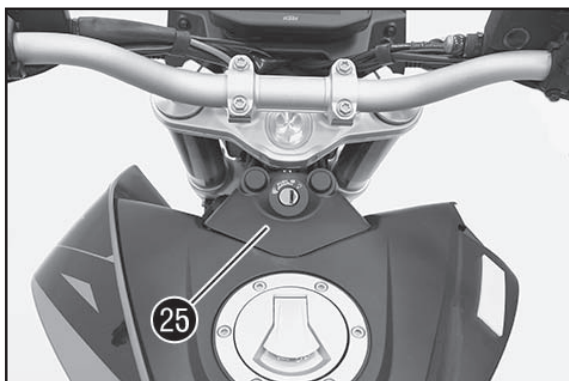

- Montar el carenado 25.

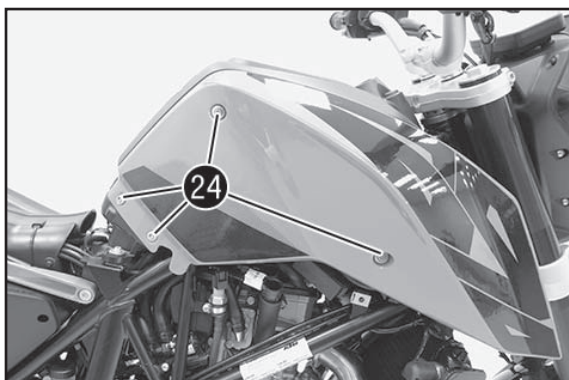

- Posicionar el spoiler.
- Montar los tornillos originales 24 y apretarlos a 3 Nm.

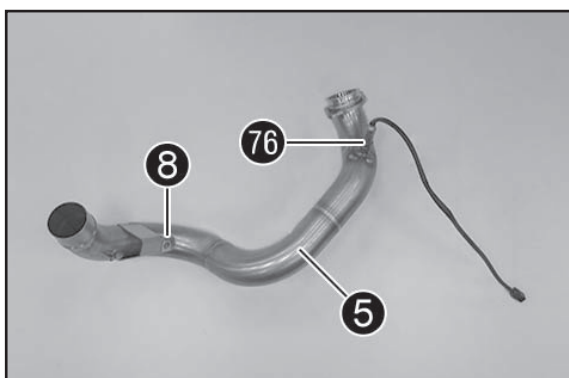

Tareas previas de montaje del colector

- Desmontar la sonda lambda 76 del colector original y montarla en el colector 5 (volumen de suministro).
- Montar la tuerca multirranco para chapa 8 (volumen de suministro).

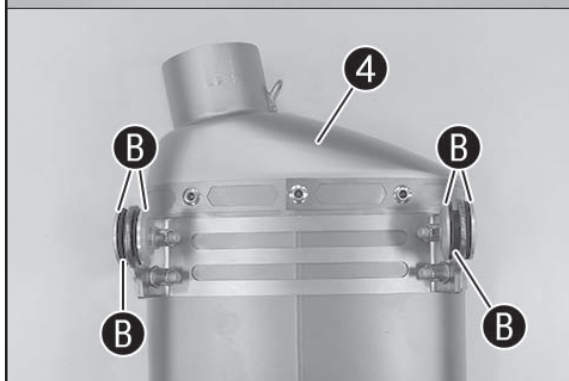

- Montar los casquillos de goma (volumen de suministro del kit de montaje B) en el soporte del presilenciador 4 (volumen de suministro).
- Montar los casquillos plateados (volumen de suministro del kit de montaje B) a la derecha e izquierda en los casquillos de goma.

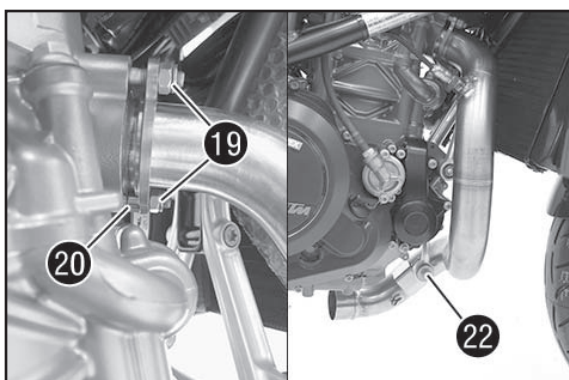

Montar el sistema de escape

- Posicionar el colector 5 (volumen de suministro) con la junta.
- Montar las tuercas originales 19 con el casquillo distanciador 20, pero no apretarlas todavía.

- Montar el tornillo original 22 con la arandela, pero no apretarlo todavía.

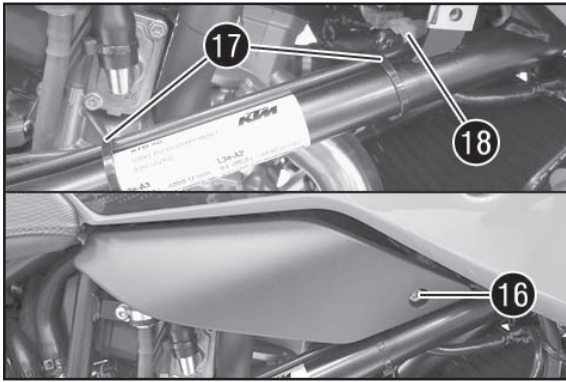

- Enchufar el conector 18 de la sonda lambda. Asegurar el cable con cinta sujetacables 17.
- Montar el carenado derecho e izquierdo.
- Montar los tornillos originales 25 a ambos lados y apretarlos a 3 Nm.

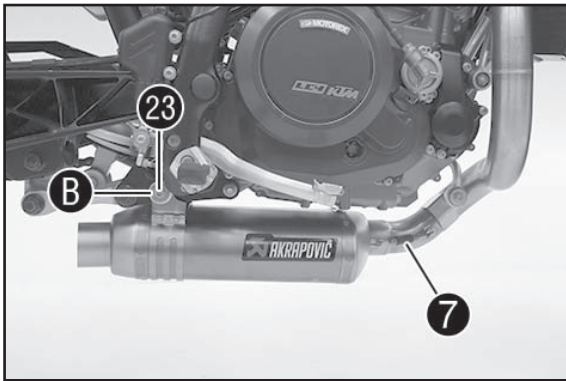

- Posicionar el presilenciador 4 (volumen de suministro).
- Montar a ambos lados los tornillos originales 23 con las arandelas (volumen de suministro del kit de montaje B), pero no apretarlos todavía.
- Montar los muelles cortos para el tubo de escape 7 (volumen de suministro).
- Apretar las tuercas 19 uniformemente a 20 Nm (engrasadas con pasta de cobre).
- Apretar el tornillo 22 a 25 Nm.
- Apretar los tornillos 23 a ambos lados a 25 Nm.

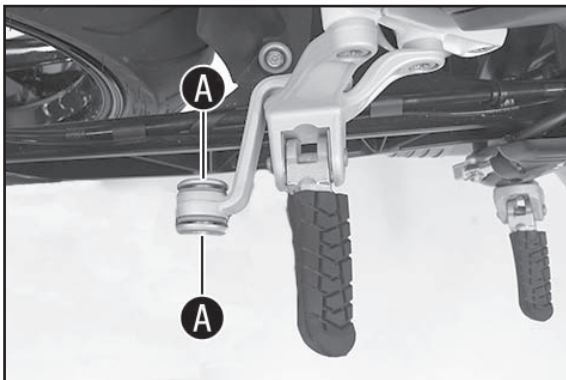

(solo Duke)

- Montar los casquillos (volumen de suministro del kit de montaje A) en la junta original.

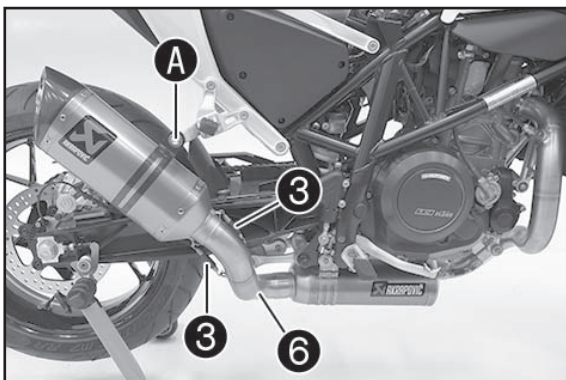

(Duke)

- Montar el tubo del colector 6 (volumen de suministro) en el presilenciador.
- Montar el silenciador 1 (volumen de suministro) con la abrazadera del tubo de escape 2 (volumen de suministro).
- Montar el tornillo (volumen de suministro del kit de montaje A) con la arandela original y la tuerca con la arandela (ambas en el volumen de suministro del kit de montaje A) y apretarlos a 15 Nm.
- Enganchar los muelles largos del sistema de escape 3 (volumen de suministro).

(Duke R)

- Montar el tubo del colector 6 (volumen de suministro) en el presilenciador.
- Montar el silenciador original con la abrazadera del tubo de escape.
- Montar el tornillo original 15 con la arandela y apretarlo a 15 Nm.
- Enganchar los muelles largos del sistema de escape 3 (volumen de suministro).

(solo Duke)

- Enganchar los muelles cortos para el tubo de escape 7 (volumen de suministro).

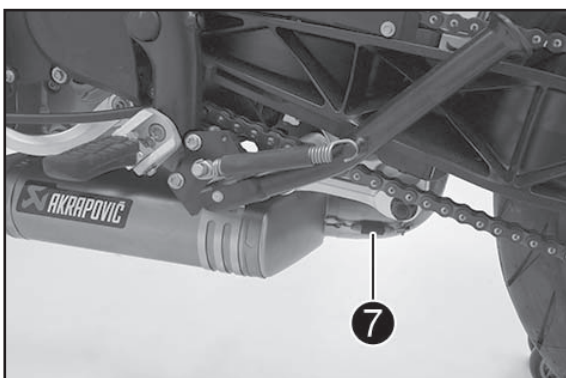

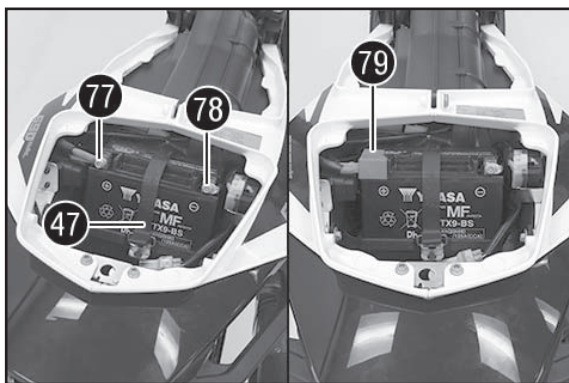

Montar la batería

- Colocar la batería en el soporte para la batería.
- ✓ Los polos de la batería miran en dirección contraria a la marcha.
- Enganchar la goma de sujeción 47.
- Conectar los dos cables del polo positivo 77 con la batería y apretar el tornillo a 2 Nm.
- Conectar los cables del polo negativo 78 con la batería y apretar el tornillo a 2 Nm.
- Montar la cubierta del polo positivo 79.

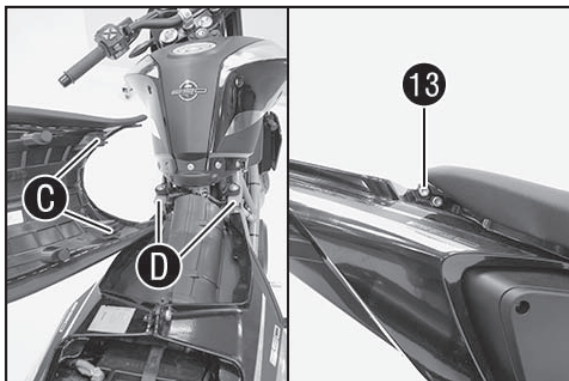

Montar el asiento del conductor

- Empujar el asiento hacia delante y bajarlo por la parte trasera.
- ✓ Los talones C engranan en las lengüetas D del chasis.
- Montar el tornillo 13 y apretarlo a 25 Nm.
- Acto seguido, comprobar si el asiento del conductor está montado correctamente.

Trabajos posteriores

- Montar el asiento del acompañante (véase el manual de instrucciones).
- Bajar la parte trasera de la motocicleta del soporte de elevación (véase el manual de instrucciones).



! AVISO

La primera vez que se utilice el silenciador, hay que mantener las revoluciones del motor a un régimen bajo durante aproximadamente 5 minutos para que el silenciador se caliente de forma uniforme. ¡Esta es la única forma de que el material insonorizante funcione perfectamente y de cumplir con los niveles acústicos establecidos!

Montaje final

Asegurarse de que el sistema de escape no está en contacto con otros componentes de la motocicleta. Eliminar los residuos de grasa con un paño suave, rociado con lubricante multiuso (Motorex Joker 440). El agente de limpieza impide que puedan producirse manchas profundas en la superficie. No utilizar agentes de limpieza químicos agresivos, pues pueden deteriorar el adhesivo. Asegurarse de que se han apretado todos los tornillos. Si el sistema de escape está en contacto con el carenado o con otros componentes, repetir el ajuste del sistema de escape o ponerse en contacto con un concesionario. Durante los primeros recorridos con un sistema de escape nuevo, es normal que salga humo blanco del silenciador. Por último, comprobar la estanqueidad del sistema de escape completo. ¡No permanecer detrás del sistema de escape al arrancar el motor por primera vez!

Mantenimiento del sistema de escape

Limpieza con un spray lubricante multiuso (Motorex Joker 440). Es normal que se produzcan cambios en el color del sistema de escape debidos a las elevadas temperaturas. El desgaste del material insonorizante del silenciador depende del tipo de motor y del estilo de conducción. Contactar con su concesionario si se aprecian cambios visibles en la vaina exterior del silenciador o si aumenta el nivel de ruidos. Comprobar periódicamente que todos los tornillos están bien apretados, y que los muelles se encuentran en su lugar.

Recambios

Kit de material insonorizante

76005979010

- Lana insonorizante
- 14x remaches D4,8x8
- 2x remaches D4,8x12

Kit de reparación

76005979220

- 1x vaina exterior de titanio
- 2x cintas de remachado de titanio
- 14x remaches D4,8x8
- 2x remaches D4,8x12
- 1x adhesivo
- 1x adhesivo con el número de patente

1x abrazadera del tubo de escape de carbono ②

76005979001

1x tapón final de carbono ⑧

76005979005

2x muelles largos para el tubo de escape ③

57305016000

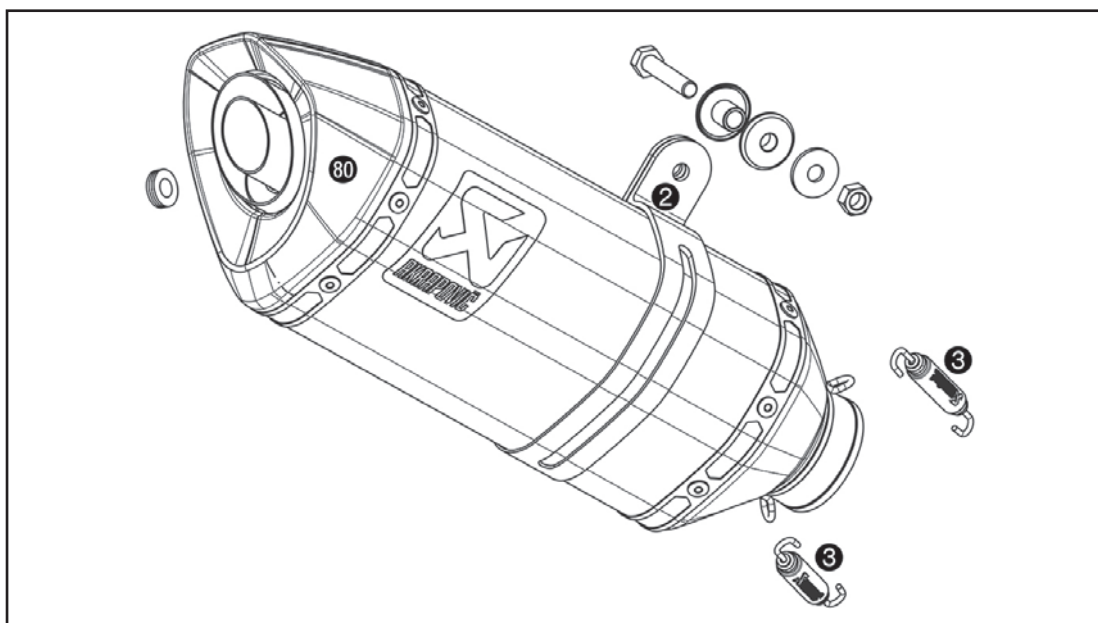

Recambios

1x adhesivo Akrapovic ⑧

60005099003

