





450 SX-F 2013

SPARE PARTS MANUAL: ENGINE

ART.NO.: 3CM089570MEN

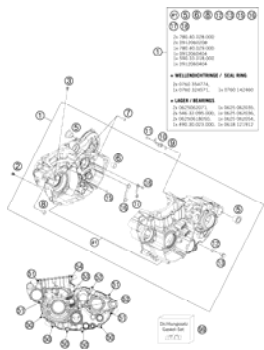
ENGLISH

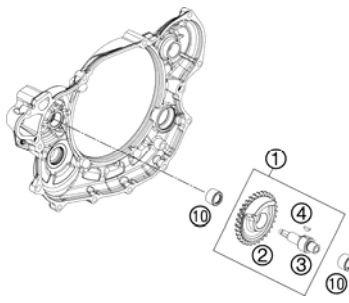
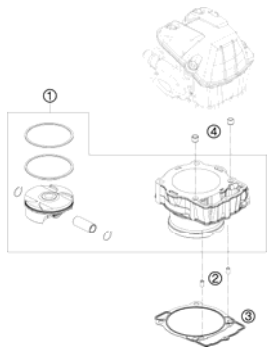
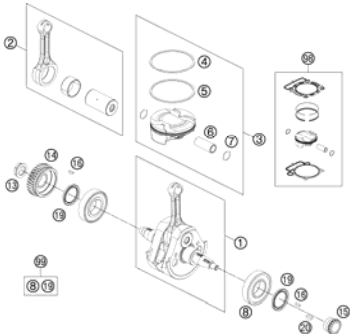
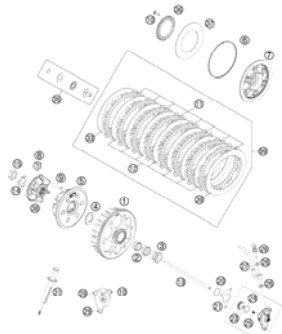
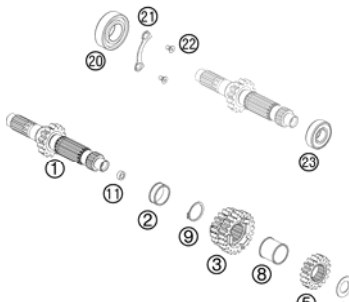

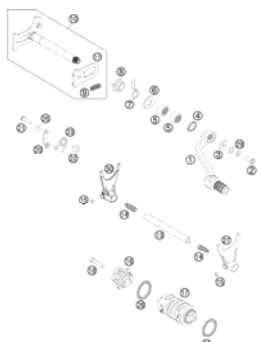
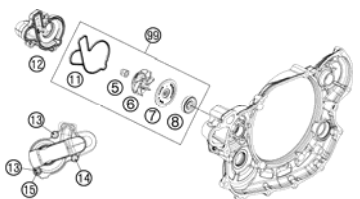
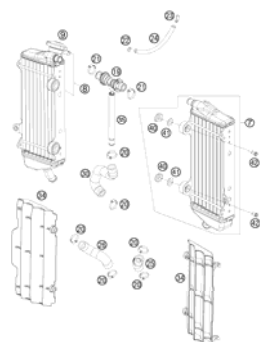
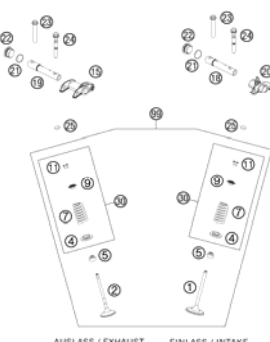
<p>ENGINE CASE</p>  <p>3</p>	<p>CLUTCH COVER</p>  <p>4</p>	<p>BALANCER SHAFT</p>  <p>5</p>	<p>CYLINDER</p>  <p>6</p>
<p>CRANKSHAFT, PISTON</p>  <p>7</p>	<p>CLUTCH</p>  <p>8</p>	<p>TRANSMISSION I - MAIN SHAFT</p>  <p>9</p>	<p>TRANSMISSION II - COUNTERSHAFT</p>  <p>10</p>
<p>SHIFTING MECHANISM</p>  <p>11</p>	<p>WATER PUMP</p>  <p>12</p>	<p>COOLING SYSTEM</p>  <p>13</p>	<p>VALVE DRIVE</p>  <p>14</p>

<p>TIMING DRIVE</p> <p>16</p>	<p>CYLINDER HEAD</p> <p>17</p>	<p>LUBRICATING SYSTEM</p> <p>18</p>	<p>IGNITION SYSTEM</p> <p>20</p>
<p>ELECTRIC STARTER</p> <p>21</p>	<p>THROTTLE BODY</p> <p>22</p>		
<div style="display: flex; align-items: center;"> <div style="background-color: #cccccc; width: 60px; height: 100px; display: flex; align-items: center; justify-content: center; margin-right: 20px;"> ! </div> <div> <p>All information contained is without obligation. KTM-Sportmotorcycle AG particularly reserves the right to modify any equipment, technical specifications, prices, colors, shapes, materials, services, service work, constructions, equipment and the like so as to adapt them to local conditions or to cancel any of the above items, all without previous announcement and without giving reasons. KTM may stop manufacturing certain models without previous notice. KTM shall not be held liable for any deviations of availability and/or ability to deliver, illustrations, descriptions, printing and/or other errors. The illustrated models partly contain extra equipment, which is not applied to standard models. © by KTM-SPORTMOTORCYCLE AG, Mattighofen AUSTRIA; All rights reserved; Reprint, also in extracts, with written allowance of KTM-SPORTMOTORCYCLE AG, Mattighofen only.</p> </div> </div>			

- #1 5 6 8 12 13 15 16
17 18
- 2x 780.40.028.000
2x 0912060208
1x 780.40.029.000
1x 0912060404
1x 590.33.018.000
1x 0912060404
- + WELLENDICHTRINGE / SEAL RING**
- 2x 0760 354774,
1x 0760 324571, 1x 0760 142460
- + LAGER / BEARINGS**
- 2x 0625062071, 1x 0625 062035,
2x 546.32.095.000, 1x 0625 062036,
2x 06250618050, 1x 0625 062054,
1x 490.30.023.000, 1x 0618 121912

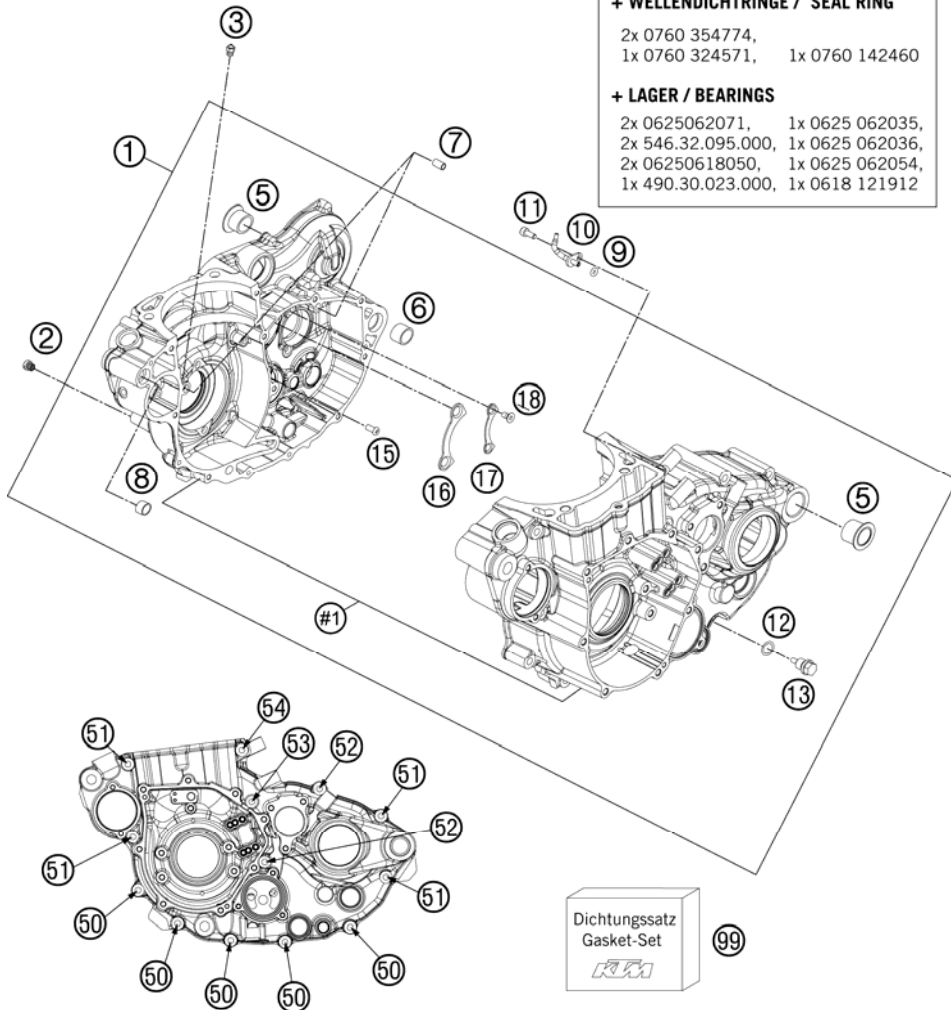

FIG	PART NUMBER	DESCRIPTION	QTY
1	78130000033	ENGINE CASE CPL.	1
2	57031523145	MAIN JET 145	1
3	60030063070	OIL JET 70 M5	1
5	75030010100	CASE BUSH	2
6	54830027000	DOWEL 21X12 03	1
7	59030023000	DOWEL 6X8X11,5	2
8	51030026100	DOWEL 17 X 13 X 12	1
9	0770035020	O-RING 3,5X2,00 NBR	1
10	81230064000	OIL JET ANGLED 70	1
11	0912040103	AH.SCREW DIN0912-M 4X10	1
12	58038022000	CU-SEAL RING DIN7603-12X18X1,5	1
13	58030021000	OILDRAIN PLUG W.MAG. M 12X1,5	1
15	0018050103	INT. TORX OVAL HEAD M 5X10 8.8	1
16	78033032000	TAB WASHER BEARING MAIN SHAFT	1
17	78033132000	TAB WASHER BEARING COUNT.SHAFT	1
18	0019050106	INT. TORX FLAT HEAD M5X10 10.9	4
50	0025060406	HH COLLAR SCREW M6X40 TX30	5
51	0025060606	HH COLLAR SCREW M6X60 TX30	4
52	0025060756	HH COLLAR SCREW M6X75 TX30	2
53	0025060806	HH COLLAR SCREW M6X80 TX30	1
54	0025060856	HH COLLAR SCREW M6X85 TX30	1
99	78130099000	GASKET SET 450/500 EXC 12	1

127813010 / C137893010

* NEW PART

X AS REQUIRED

CLUTCH COVER

450 SX-F 2013

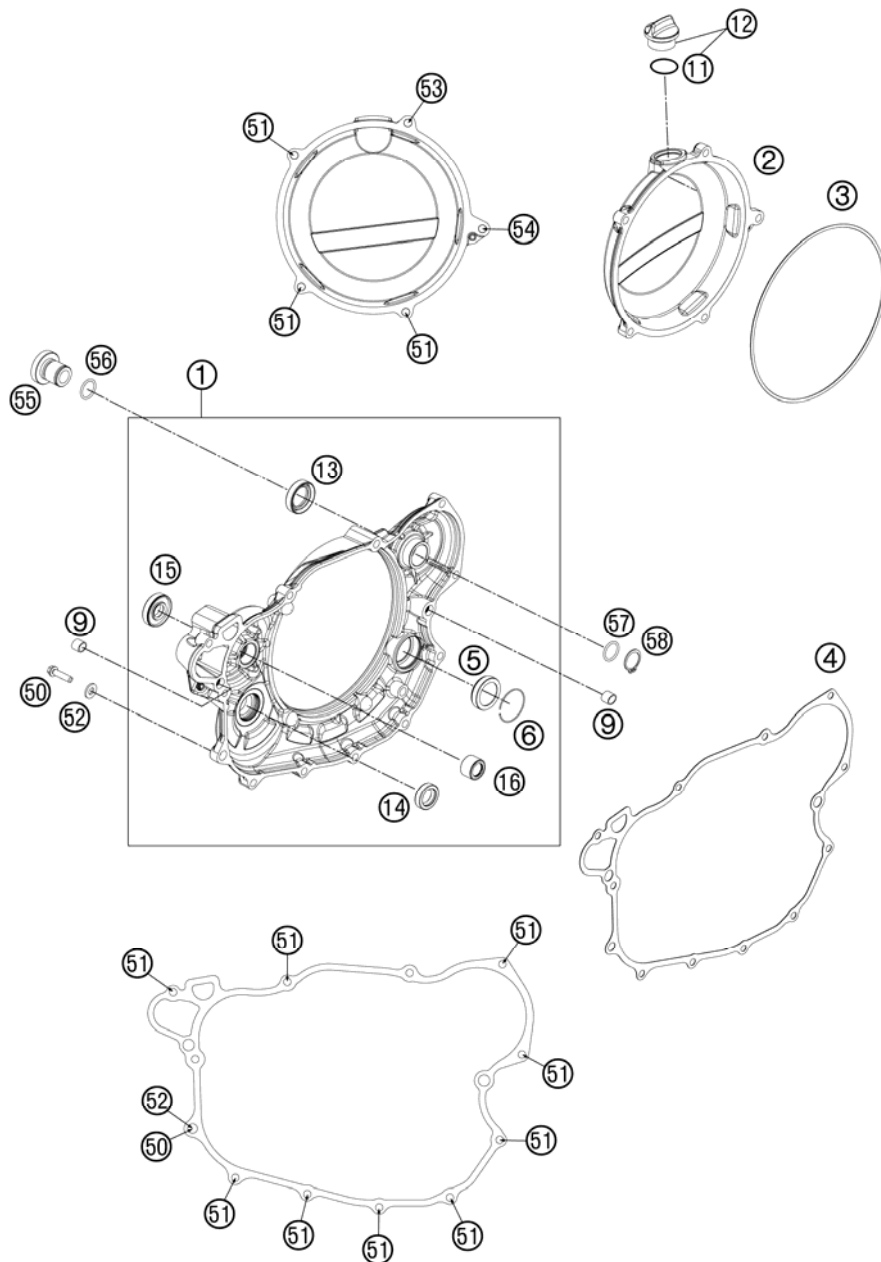

FIG	PART NUMBER	DESCRIPTION	QTY
1	78130001144	CLUTCH COVER CPL.	1
2	7813002600015	CLUTCH COVER OUTSIDE	1
3	78130027000	GASKET - CLUTCH OUTER COVER	1
4	78130025000	CLUTCH COVER GASKET	1
5	78030095100	OIL LEVEL GLASS VITON	1
6	61030019050	CIRCLIP OIL LEVEL GLASS 03	1
9	49030090000	DOWEL 9,8 X 7 X 10	2
11	0770191015	O-RING 19,00X3,00 NBR	1
12	58030120000	OIL FILLER CAP M24x3 WITH O-R	1
13	0760193070	SHAFT SEAL RING 19X30X7 B	1
14	0760142472	SHAFT SEAL RING 14X24X7 VITON	1
15	0760123073	SHAFT SEAL RING 12X30X7 PTFE	1
16	0618121912	NEEDLE BUSH NK1212	1
50	78030080000	LOCATING SCREW	1
51	0025060256	HH COLLAR SCREW M6X25 TX30	12
52	58030081000	CU-SEAL RING 8 X 14 X 3	1
53	0025060556	HH COLLAR SCREW M6X55 TX30	1
54	0025060606	HH COLLAR SCREW M6X60 TX30	1
55	83033056000	KICK-STARTER PLUG	1
56	0770160021	O-RING 16,00X2,00 VITON	1
57	0770180020	O-RING 18,00X2,00 NBR 70	1
58	0471190120	CIRCLIP DIN0471-19X1,2	1

137893020 / C137893020

* NEW PART

X AS REQUIRED

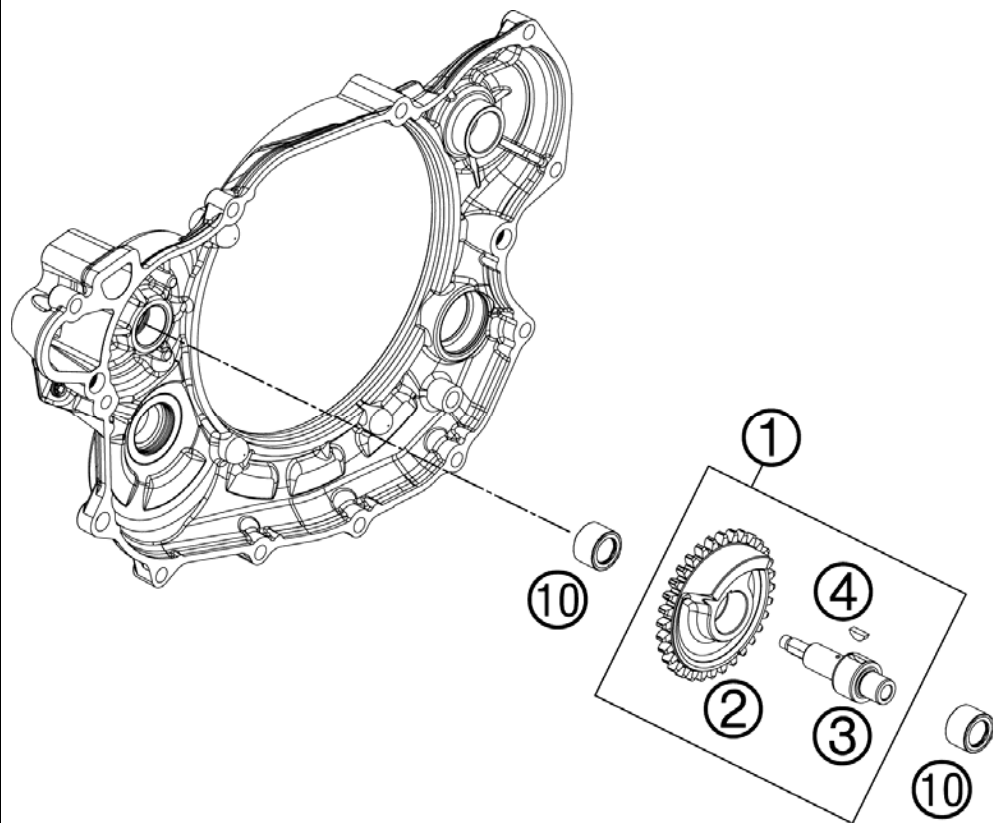

FIG	PART NUMBER	DESCRIPTION	QTY
1	78130056100	BALANCE SHAFT	1
2	78130056132	BALANCE SHAFT GEAR	1
3	78130056101	BALANCE SHAFT	1
4	0888030037	WOODRUFF KEY DIN6888-3X3,7	1
10	0618121912	NEEDLE BUSH NK1212	2

137893030 / C137893030

* NEW PART

X AS REQUIRED

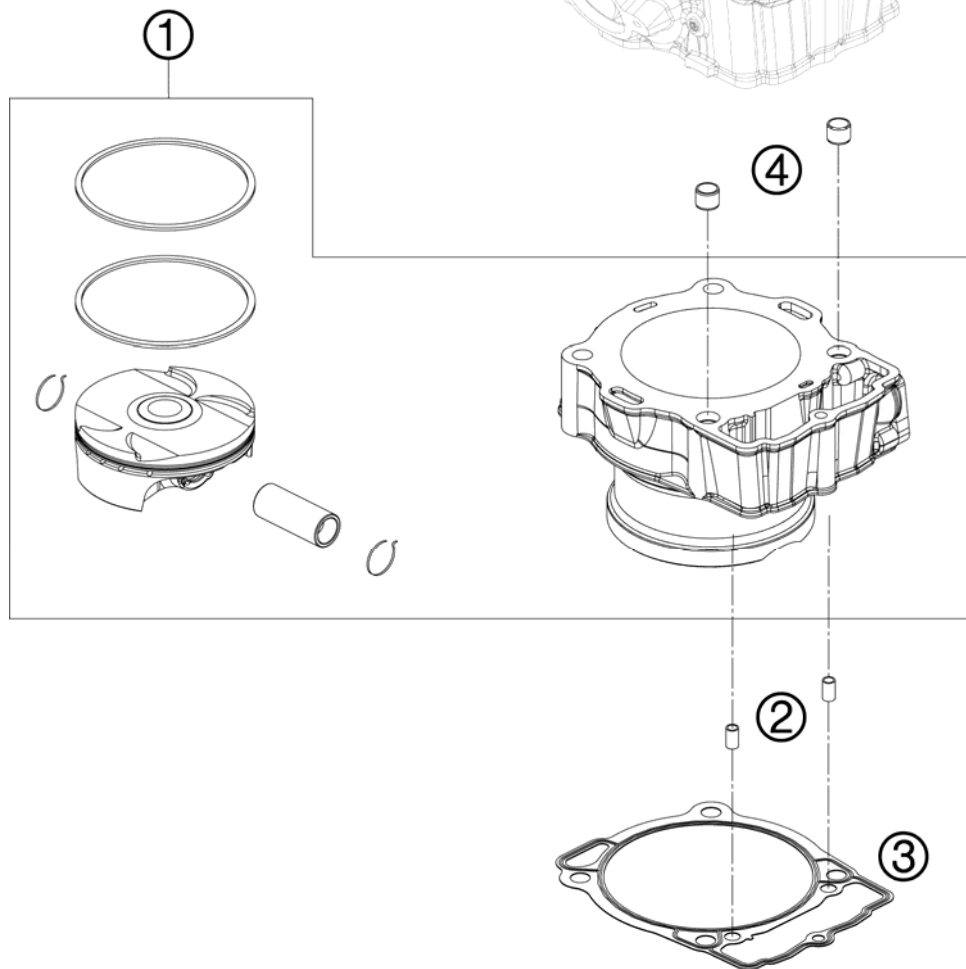
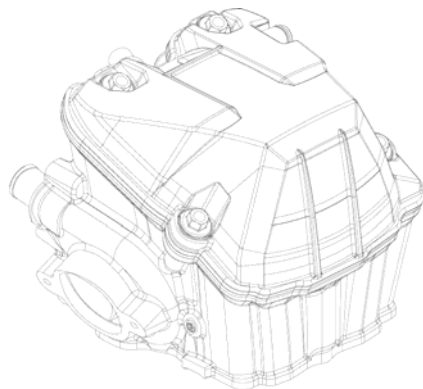

FIG	PART NUMBER	DESCRIPTION	QTY
1	78930038000	CYLINDER + PISTON CPL.	1
2	59030023000	DOWEL 6X8X11,5	2
3	78030035000	CYLINDER BASE GASKET	1
4	58530014000	DOWEL 10,2X12,5X10 2001	2

127813040 / C137893040

* NEW PART

X AS REQUIRED

CRANKSHAFT, PISTON

450 SX-F 2013

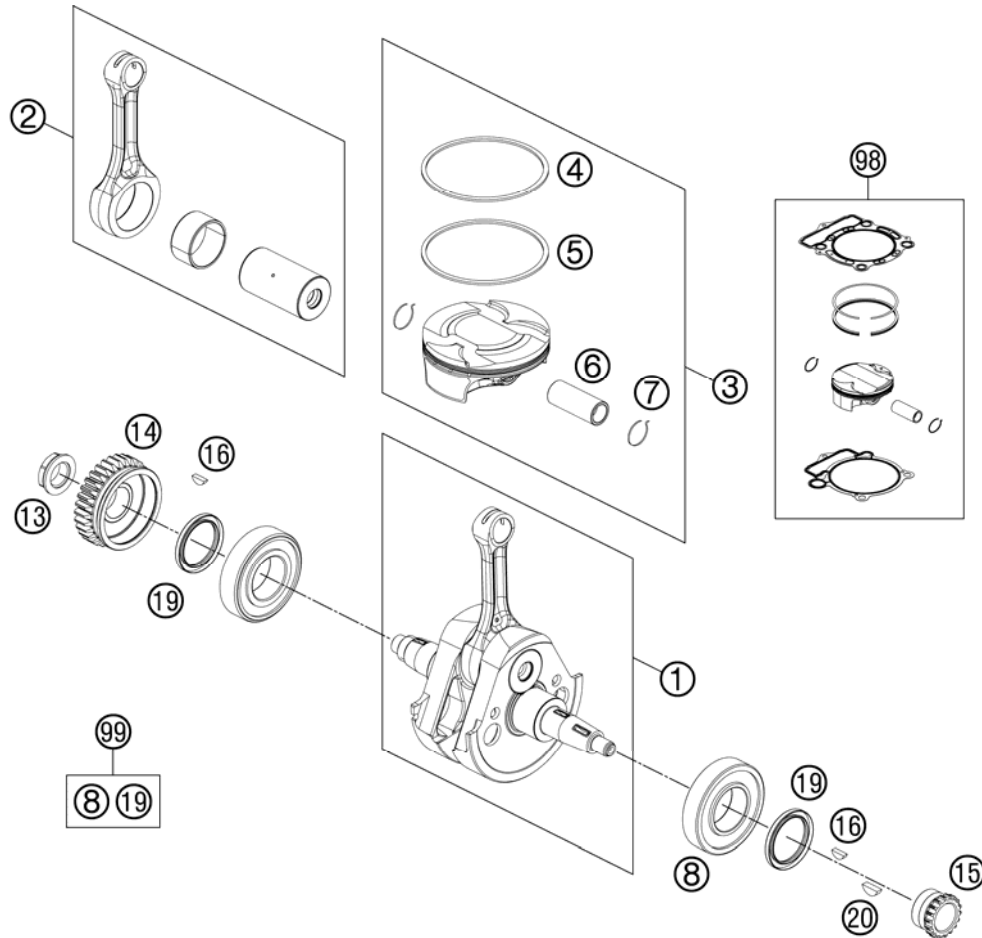

FIG	PART NUMBER	DESCRIPTION	QTY
1	78930018000	CRANKSHAFT CPL.	1
2	78930015044	CON. ROD. REP. KIT	1
3	78930007000 I	PISTON I D=95MM	1
3	78930007000 II	PISTON II D=95MM	1
4	78930030000	COMPRESSION RING	1
5	78930032000	OIL SCRAPER RING	1
6	78930033000	PISTON PIN	1
7	78930074000	CIRCLIP	2
8	0625062071	BALL BEARING 6207 TM-SX07E 39	2
13	78030029200	NUT PRIMARY WHEEL M20X1,5	1
14	78132000032	PRIMARY GEAR	1
15	78036014200	TIMING GEAR 18T.	1
16	0888030037	WOODRUFF KEY DIN6888-3X3,7	2
19	0760354774	SHAFT SEAL RING 35X47X7 VITON	2
20	0888030050	WOODRUFF KEY DIN6888-3X5X13	1
98	00050000218	PISTON KIT GR. I 450 SX-F 13	x
98	00050000219	PISTON KIT GR. II 450 SX-F 13	x
99	00050002310	CRANKSHAFT REP. KIT 450 SX-F13	x

137893060 / C137893060

* NEW PART

X AS REQUIRED

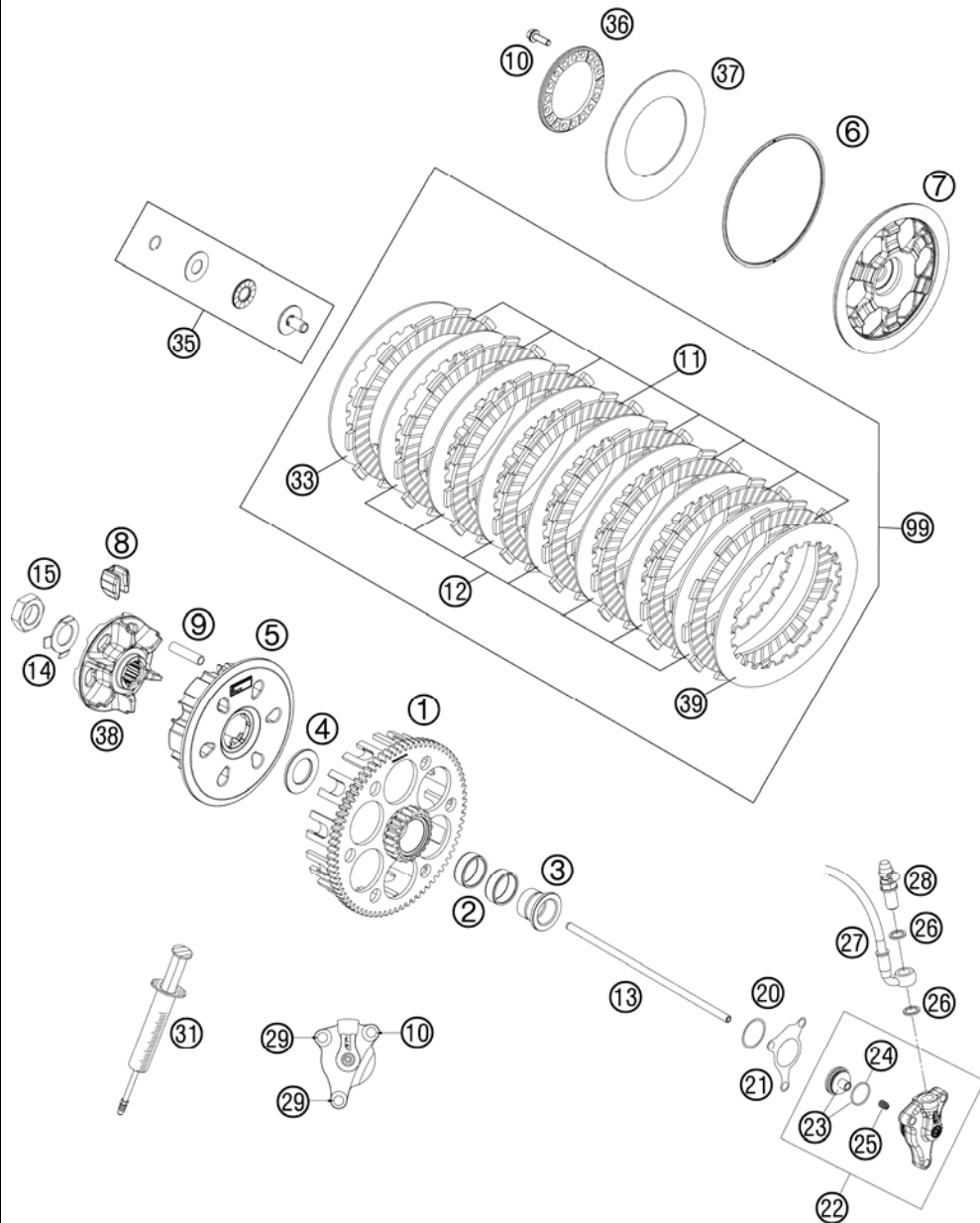

FIG	PART NUMBER	DESCRIPTION	QTY
1	78132001076	CLUTCH CAGE	1
2	0405252910	NEEDLE BEAR K 25X29X10	2
3	78132015100	COLLARSLEEVE	1
4	77232009100	WASHER 21,8 X 37 X 3	1
5	78132002008	INNER CLUTCH HUB	1
6	78132013000	WASHER 112X118X1.5	1
7	78132003000	PRESSURE PLATE	1
8	78132025100	DAMPING RUBBER	6
9	78132004000	SLEEVE 7,5X33.4	6
10	0025050166	HH COLLAR SCREW M5X16 TX30	6
11	59032011100	LINING DISC 2MM 04	8
12	59032010200	INTERMEDIATE DISC 1,4MM 2002	7
13	78132054100	PUSH ROD	1
14	78132018000	TAB WASHER	1
15	0936181505	HEXAGON NUT DIN0936-M18X1,5 R.	1
20	0770300015	O-RING 30,00X1,50 NBR 70	1
21	59032065000	GASKET FOR SLAVE CYLINDER	1
22	54832061044	OUTPUT CYLINDER CPL. 06	1
23	54832066000	PISTON CPL.	1
24	54832067000	O-RING	1
25	54832069000	PRESSURE SPRING	1
26	0603100141	COPPER GASKET DIN7603-10X14X1	2
27	78132063000	CLUTCH PIPE	1
28	62513020000	BLEEDER SCREW CPL. 05	1
29	0025060206	HH COLLAR SCREW M6X20 TX30	2
31	50329050000	VENT INJEKTION HYDR. CLUTCH	1
33	59032010100	INTERMEDIATE DISC 1MM 2002	1
35	78132057044	PRESSURE PIECE CPL.	1
36	78132006100	SPRING RING	1
37	78132005000	BELLEVILLE SPRING 71X115X1,5 I	1
38	78132002111	HUB	1
39	78932010000	INTERMEDIATE DISC 1,2MM	1
99	78932010033	CLUTCH DISC KIT	1

137893210 / C137893210

* NEW PART

X AS REQUIRED

TRANSMISSION I - MAIN SHAFT

450 SX-F 2013

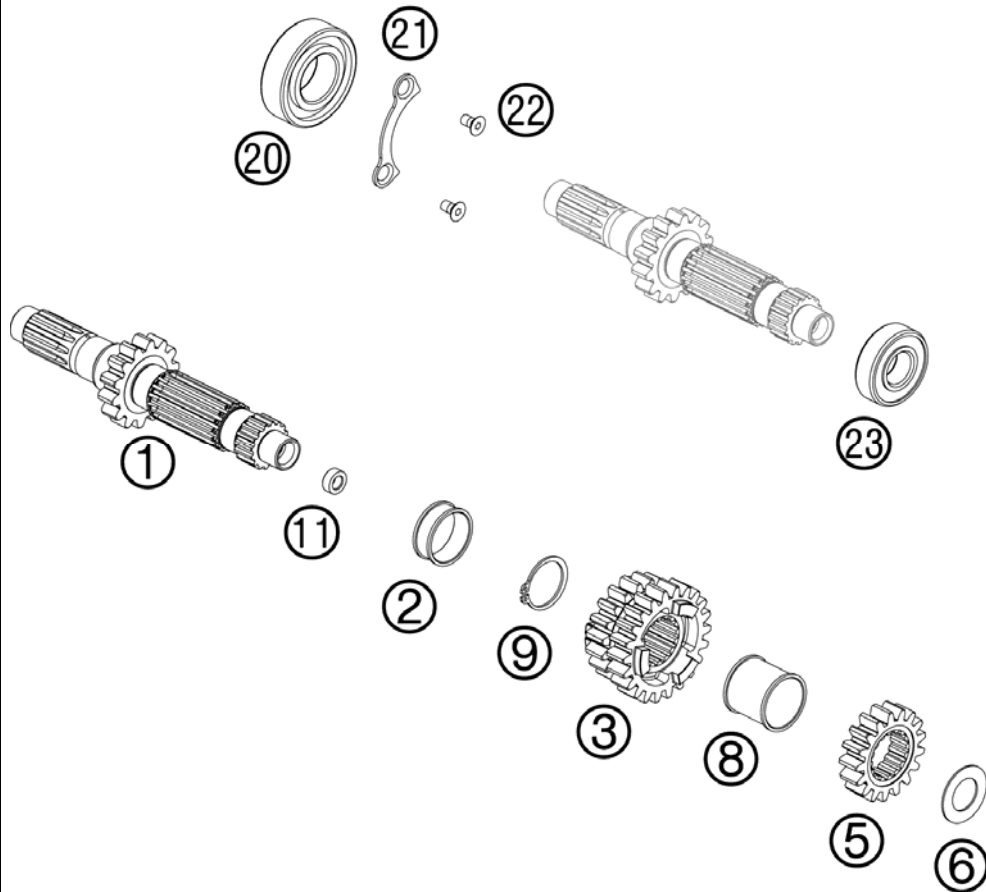

FIG	PART NUMBER	DESCRIPTION	QTY
1	78133101050	MAIN SHAFT 16 T.	1
2	78933033000	SPACER SLEEVE	1
3	78933003000	SLIDING GEAR 3/4 G.	1
5	78033102000	SOLID GEAR 2.G.	1
6	56033030000	STOP DISC 17,2X30X1	1
8	78933034000	SPACER SLEEVE	1
9	0471250120	CIRCLIP DIN0471-25X1,2	1
11	78033001110	BUSHING	1
20	0625062054	BALL BEARING 6205 C3 NTN	1
21	78033032000	TAB WASHER BEARING MAIN SHAFT	1
22	0019050106	INT. TORX FLAT HEAD M5X10 10.9	2
23	0625062036	BALL BEARING 6203 RSH C3	1

137893331 / C137893331

* NEW PART

X AS REQUIRED

TRANSMISSION II - COUNTERSHAFT

450 SX-F 2013

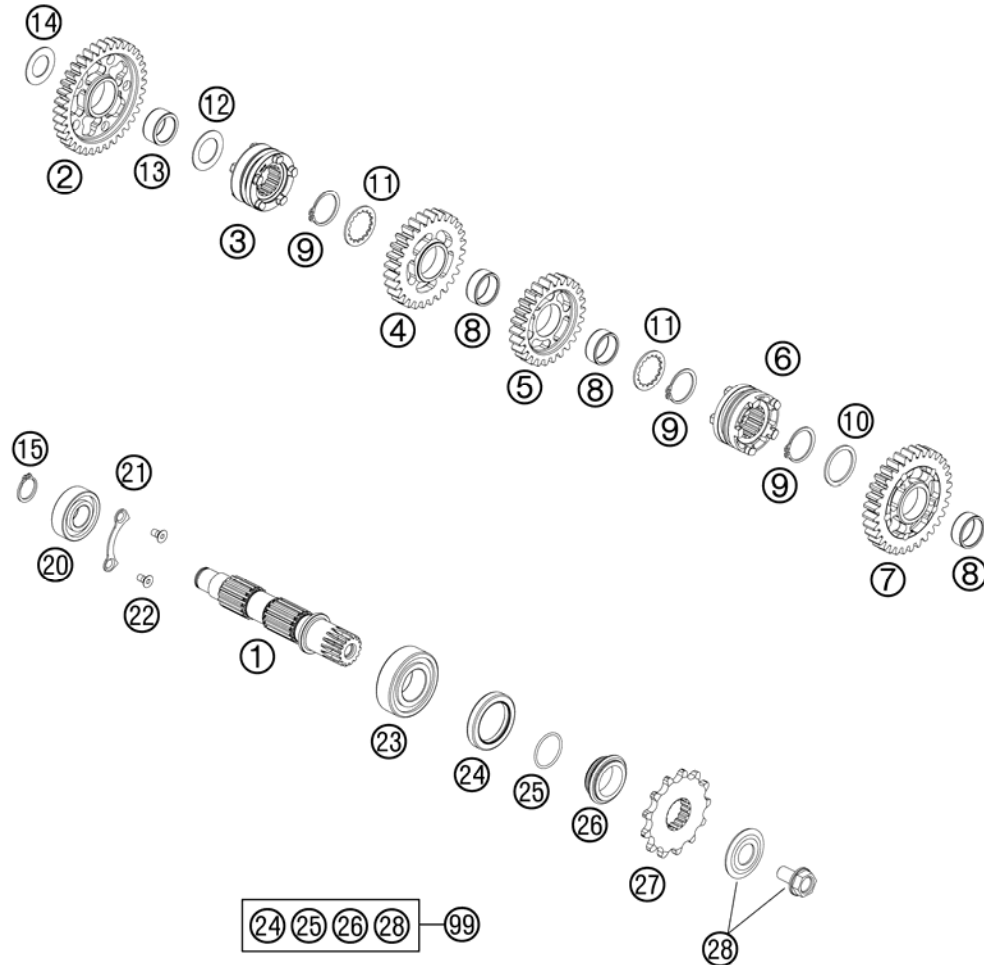

FIG	PART NUMBER	DESCRIPTION	QTY
1	78033010000	COUNTERSHAFT 08	1
2	78033111100	IDLER GEAR 1.G.	1
3	78933017000	SHIFT COLLAR 1. + 3. GEAR	1
4	78933013000	IDLER GEAR 3.G.	1
5	78933014000	IDLER GEAR 4.G.	1
6	78933018000	SHIFT COLLAR	1
7	78033112100	IDLER GEAR 2.G.	1
8	0405222611	NEEDLE BEAR.K 22X26X10 DIVIDED	3
9	0471250120	CIRCLIP DIN0471-25X1,2	3
10	78033031000	STOP DISK 26 X 32 X 1,5	1
11	78033033000	STOP DISK 23 X 32 X 1,5	2
12	59033080000	SHIM 20X32X1	1
13	0405202612	NEEDLE BEARING K 20X26X12	1
14	56033030000	STOP DISC 17,2X30X1	1
15	0471170015	CIRCLIP DIN 0471-17X1, 5	1
20	0625062035	BALL BEARING 6203 JR2 C3	1
21	78033132000	TAB WASHER BEARING COUNT.SHAFT	1
22	0019050106	INT. TORX FLAT HEAD M5X10 10.9	2
23	49030023000	CYL.ROLL BEARING NJ205	1
24	0760324571	SHAFT SEAL RING 32X45X7 BSLNBR	1
25	0770020220	O-RING 25,12X1,78 NBR70	1
26	78133014000	SPACER SLEEVE COUNTER	1
27	50033029013	FRONT SPROCKET 13-T	x
27	50033029014	FRONT SPROCKET 14-T	1
27	50033029015	FRONT SPROCKET 15-T	x
28	59033034044	SCREW 10.9+SPRING WASHER	1
99	00050000941	COUNTER SHAFT REP.KIT 4 STROKE	x

137893361 / C137893361

* NEW PART

X AS REQUIRED

SHIFTING MECHANISM

450 SX-F 2013

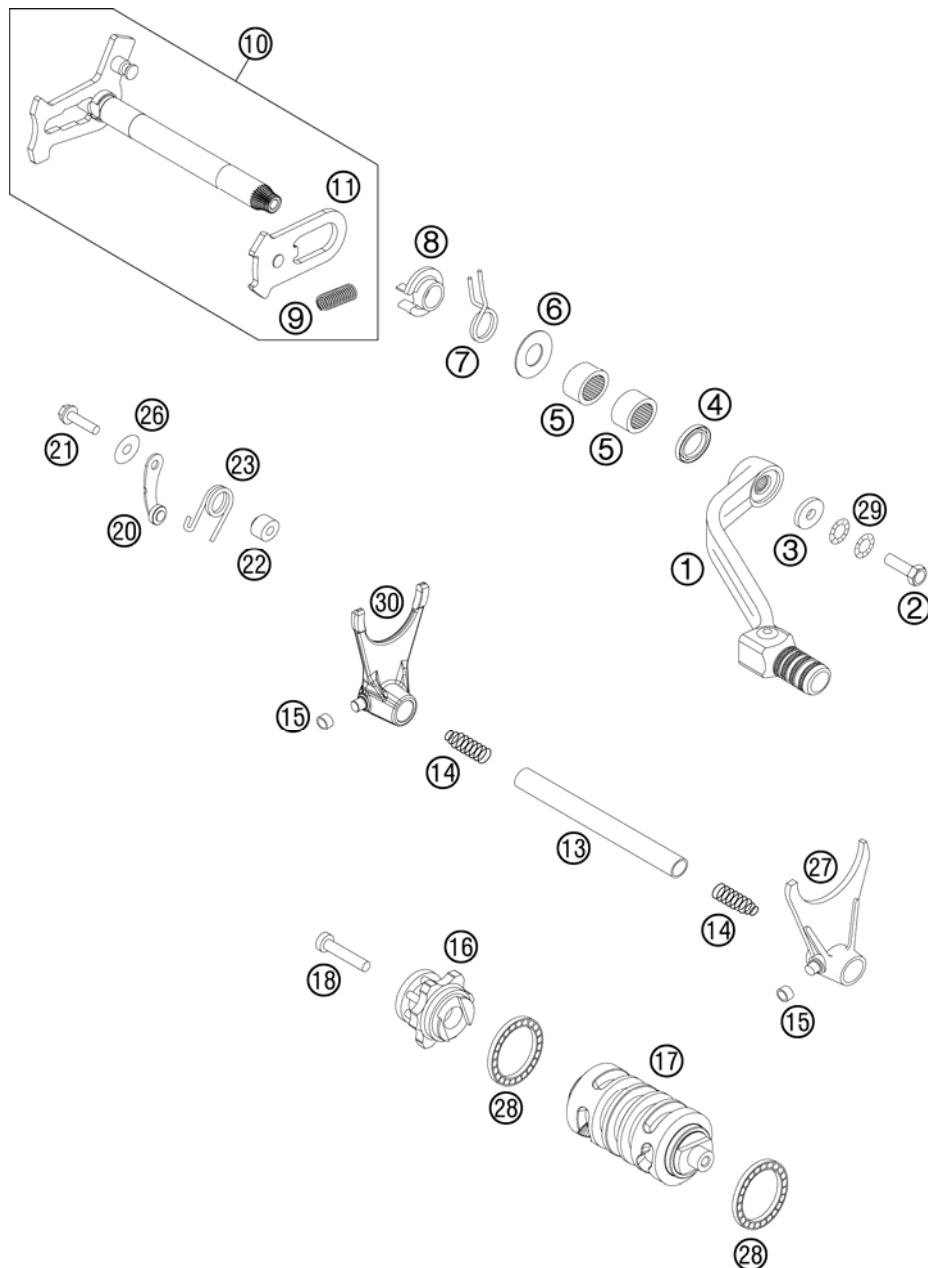

FIG	PART NUMBER	DESCRIPTION	QTY
1	59034031000	SHIFT LEVER CPL.RACING 2000	1
2	59009062016	SPECIAL SCREW M6X16 WS=8 10.9	1
3	50232050001	STEEL WASHER 6,4X17X3	1
4	0760142460	SHAFT SEAL RING 14X24X6 B	1
5	54632095000	NEEDLE BEAR.HK 1412 14X20X12	2
6	54634050000	STOP DISK 14X30X1	1
7	54634014100	RETURN SPRING 2,2MM '95	1
8	54634020000	SPRING GUIDE	1
9	56534013100	TENSIONING SPRING 0,8MM	1
10	78034005044	SHIFT SHAFT CPL.	1
11	54634008044	SLIDING PLATE CPL.	1
13	78034020000	SHIFT RAIL 11,8X101,5	1
14	58038023200	PRESSURE SPRING 0,9MM	2
15	50334018100	SHIFTING ROLLER 6X8X5,2	2
16	78134015044	SHIFT DRUM LOCATING ALU CPL.	1
17	78934012000	SHIFT ROLLER	1
18	0912060303	AH SCREW DIN0912-M 6X30	1
20	78134024044	LOCKING LEVER CPL.	1
21	0025050206	HH COLLAR SCREW M5X20 TX30	1
22	54634052300	SLEEVE FOR LOCKING LEVER	1
23	60034023000	ARRESTING LEVER SPRING 03	1
26	0021050003	WASHER DIN9021-A 5,3	1
27	59034002000	SHIFT FORK 2./4.GEAR 2000	1
28	0625618050	BALL BEARING 61805 C3	2
29	50233041000	PAIR OF WASHERS M 6 NORDLOCK	1
30	78034003000	SHIFTING FORK 1ST/3RD GEAR	1

137893411 / C137893411

* NEW PART

X AS REQUIRED

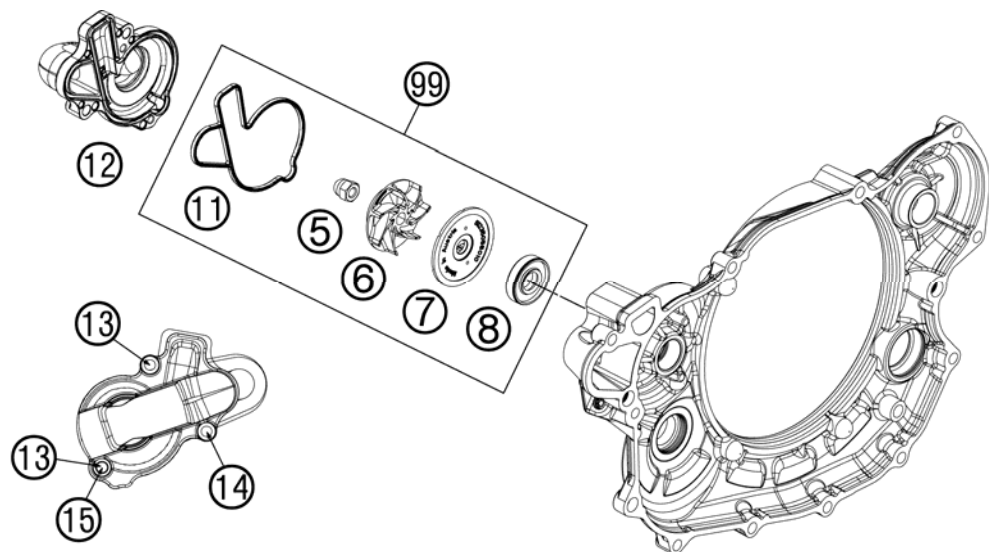

FIG	PART NUMBER	DESCRIPTION	QTY
5	61230045000	CAP NUT M6 STAINLESS STEEL	1
6	81235055020	WATER PUMP ROTOR	1
7	81235055110	DISC WATER PUMP	1
8	0760123073	SHAFT SEAL RING 12X30X7 PTFE	1
11	78135053000	WATER-PUMP GASKET	1
12	78135052000	WATER PUMP COVER CPL.	1
13	0025060256	HH COLLAR SCREW M6X25 TX30	2
14	0025060656	HH COLLAR SCREW M6X65 TX30	1
15	0603061001	CU-SEAL RING DIN7603-6X10X1	1
99	81235055015	WATER PUMP REP. KIT 12	x

137893510 / C137893510

* NEW PART

X AS REQUIRED

COOLING SYSTEM

450 SX-F 2013

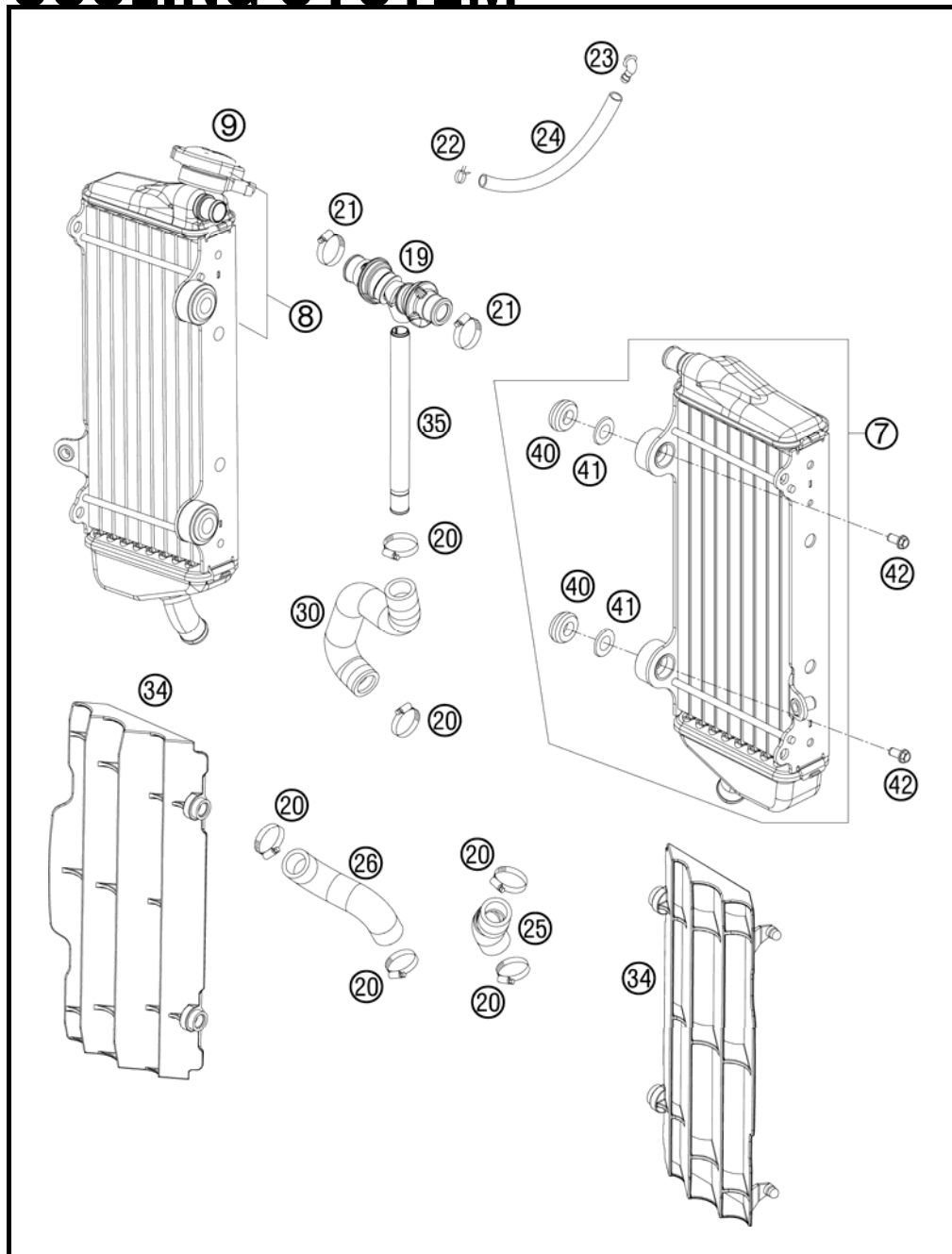
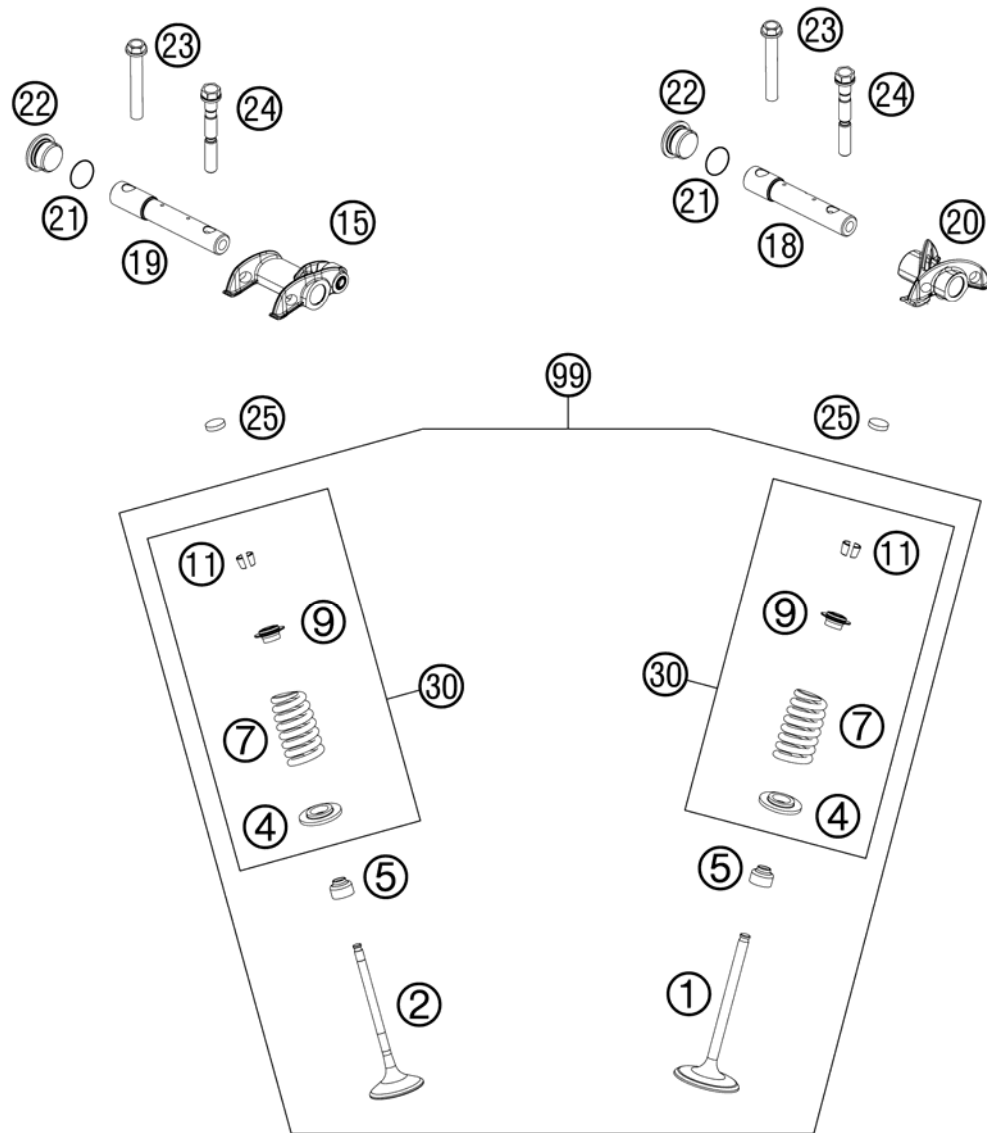

FIG	PART NUMBER	DESCRIPTION	QTY
7	77035007300	RADIATOR L/S "55623U" 12	1
8	77235008100	RADIATOR R/S "55637U" 13	1
9	77335016000	RADIATOR CAP SMALL 1,8 BAR	1
19	77235071044	Y-CONNECOTOR CPL.	1
20	10001020000	HOSE CLAMP GEMI 16-27	6
21	42013037400	HOSE CLAMP NORMA 12/24	2
22	59007017000	CLAMP YDNAC 10096F (9,6MM)	1
23	50303089000	ANGLE PIECE '97	1
24	50335030001	PVC-HOSE 6X9	x
25	78135025000	RADIATOR HOSE L/S 2012	1
26	78135027000	RADIATOR HOSE R/S 2012	1
30	78935024000	PREFORMED HOSE ENGINE/COOLER	1
34	7733503400004	RADIATOR PROTECTION L/S+R/S SX	x
34	7733503400030	RADIATOR PROTECTION BLACK 07	2
35	77235073000	HOSE CONNECTOR L=172,5	1
40	41001052000	RUBBER SLEEVE D=12MM	4
41	77335001000	WASHER FOR RADIATOR 08	4
42	0023060123	COLLAR SCREW M6X12 TX	4

137893530 / C137893530

* NEW PART

X AS REQUIRED



AUSLASS / EXHAUST

EINLASS / INTAKE

FIG	PART NUMBER	DESCRIPTION	QTY
1	78936030000	INTAKE VALVE	2
2	78936031000	EXHAUST VALVE	2
4	78936036000	VALVE SPRING HOLDER	4
5	59036027000	VALVE-STEM SEALING RACING	4
7	78936028000	VALVE SPRING	4
9	78936032000	VALVE SPRING RETAINER	4
11	77336033100	VALVE COLLET 07	8
15	78936061044	ROCKER ARM EXHAUST CPL.	1
18	78936056000	ROCKER ARM INTAKT	1
19	78936057000	ROCKER ARM EXHAUST	1
20	78936060000	ROCKER ARM INTAKE	1
21	0770150151	O-RING 15,00X1,50 VITON	2
22	78936081000	SCREW PLUG M18X1.5	2
23	77036080000	SPECIAL SCREW M7X40 WS10	2
24	78036080000	FIT BOLT M7X1X55	2
25	77036035172	SHIM D=8,9/1,72	X
25	77036035176	SHIM D=8,9/1,76	X
25	77036035180	SHIM D=8,9/1,80	X
25	77036035184	SHIM D=8,9/1,84	X
25	77036035188	SHIM D=8,9/1,88	X
25	77036035192	SHIM D=8,9/1,92	X
25	77036035196	SHIM D=8,9/1,96	X
25	77036035200	SHIM D=8,9/2,00	X
25	77036035204	SHIM D=8,9/2,04	X
25	77036035208	SHIM D=8,9/2,08	X
25	77036035212	SHIM D=8,9/2,12	X
25	77036035216	SHIM D=8,9/2,16	X
25	77036035220	SHIM D=8,9/2,20	X
25	77036035224	SHIM D=8,9/2,24	X
25	77036035240	SHIM D=8,9/2,40	X
25	77036035244	SHIM D=8,9/2,44	X
25	77036035248	SHIM D=8,9/2,48	X
25	77036035252	SHIM D=8,9/2,52	X
25	77036035256	SHIM D=8,9/2,56	X
25	77036035260	SHIM D=8,9/2,60	X

137893610 / C137893610

* NEW PART

X AS REQUIRED

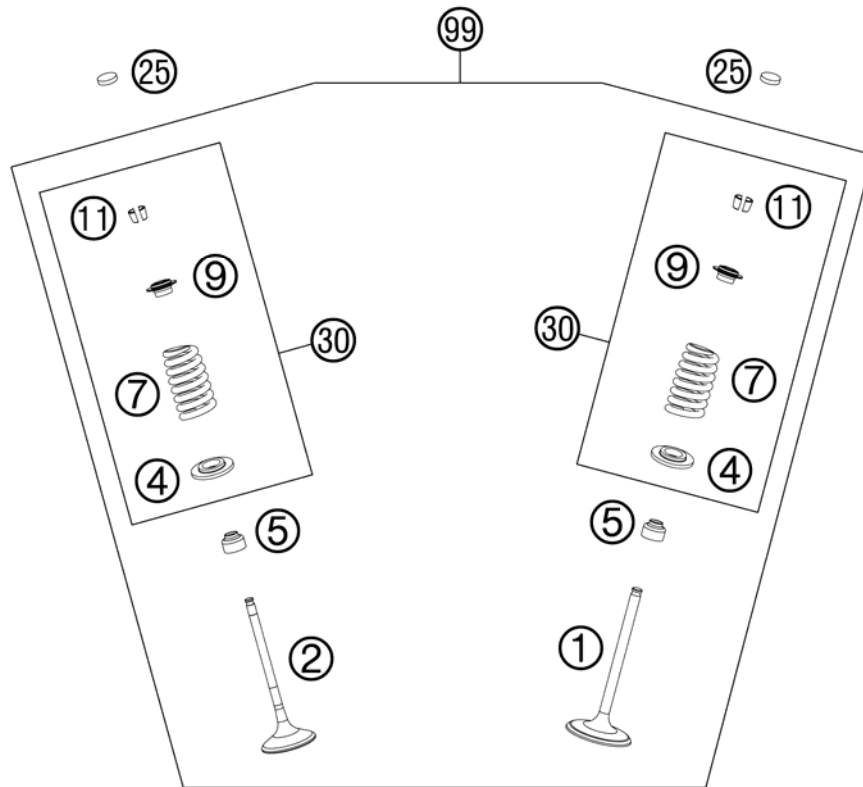

AUSLASS / EXHAUST

EINLASS / INTAKE

FIG	PART NUMBER	DESCRIPTION	QTY
25	77036035228	SHIM D=8,9/2,28	X
25	77036035232	SHIM D=8,9/2,32	X
25	77036035236	SHIM D=8,9/2,36	X
30	78936029044	VALVE SPR.-KIT 450 SX-F 13	X
99	78936030010	VALVE KIT 450 SX-F 13	X

137893610 / C137893610

* NEW PART

X AS REQUIRED

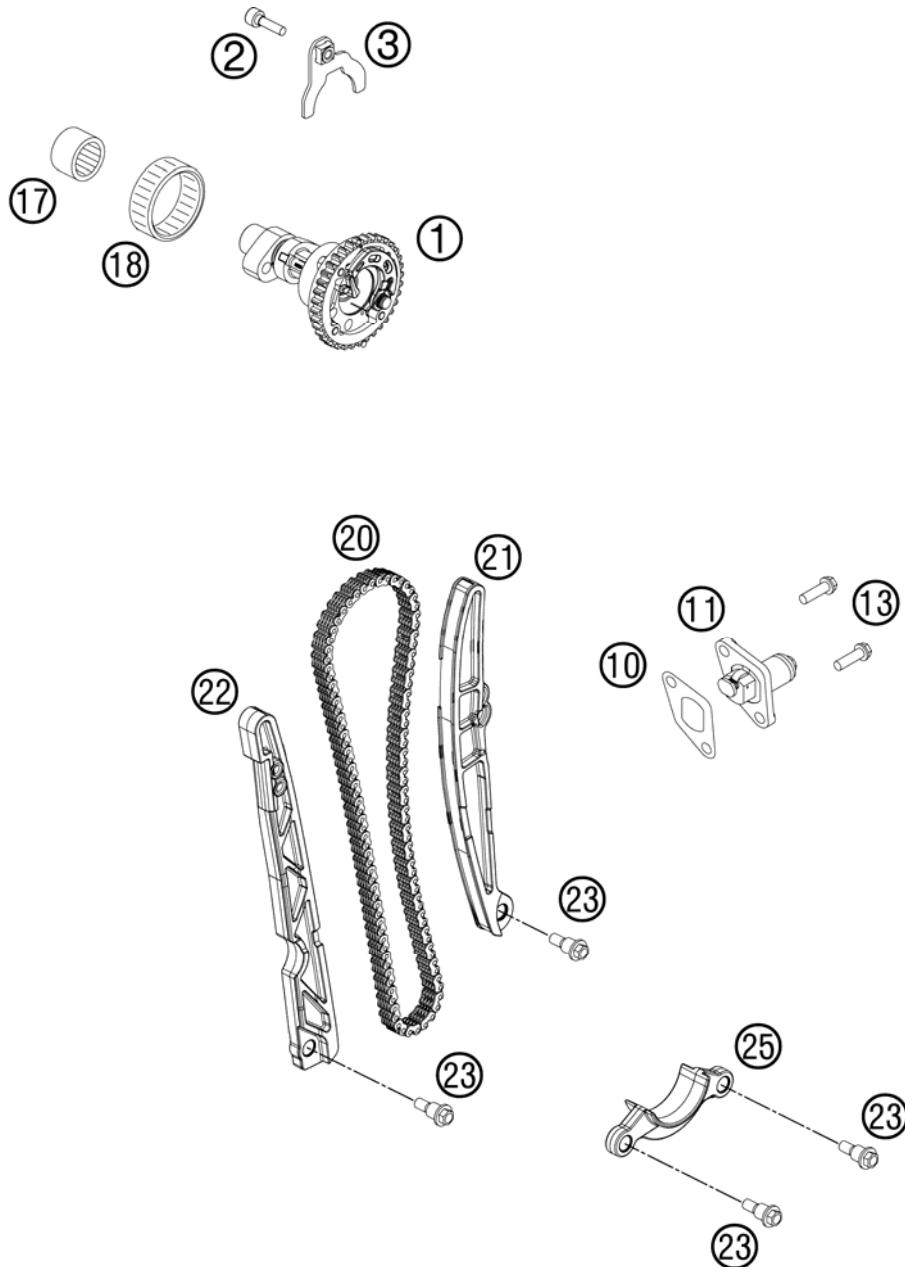

FIG	PART NUMBER	DESCRIPTION	QTY
1	78936010033	CAMSHAFT W. AUTODECO	1
2	0025060206	HH COLLAR SCREW M6X20 TX30	1
3	78036012033	RETAINING PLATE CAMSHAFT CPL.	1
10	59036003050	GASKET TIMING CHAIN TENSIONER	1
11	59036003000	TIMINGCHAIN TENSIONER CPL.RAC.	1
13	0025060166	HH COLLAR SCREW M6X16 TX30	2
17	0618182414	NEEDLE SLEEVE HK1814RS18/24/14	1
18	0618404712	NEEDLE SLEEVE HK4012B40X47X12	1
20	78036013000	TIMING CHAIN 110T 08	1
21	78136002100	TIMING CHAIN TENSIONER	1
22	78136001000	TIMING CHAIN GUIDE	1
23	77236001060	BUSHING SCREW M6	4
25	78136018000	FAILURE PROTECTION	1

137893620 / C137893620

* NEW PART

X AS REQUIRED

CYLINDER HEAD

450 SX-F 2013

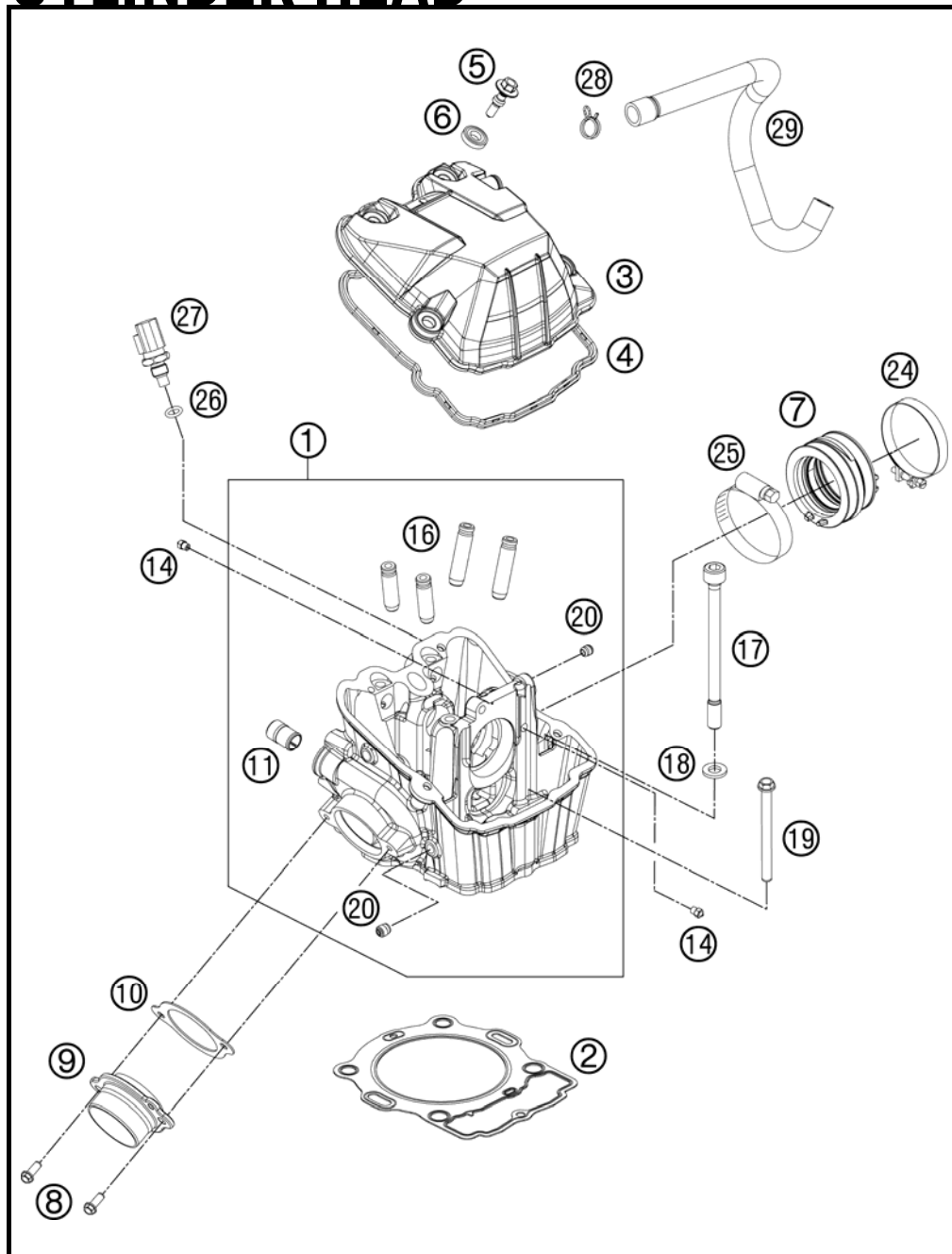

FIG	PART NUMBER	DESCRIPTION	QTY
1	78936020044	CYLINDER HEAD CPL.	1
2	78030036000	CYLINDER HEAD GASKET	1
2	78130036000	CYLINDER HEAD GASKET (DN95)	x
2	78130036200	CYLINDER HEAD GASKET 1,15MM	x
3	7803605200033	VALVE COVER BLACK MATT	1
4	78036053000	VALVE COVER GASKET	1
5	78036054100	VALVE COVER SCREW	4
6	75036052010	DECOUPLING ELEMENT	07
7	77736044000	RUBBER BOOT EFI	1
8	0025060166	HH COLLAR SCREW M6X16	TX30
9	78136139000	EXHAUST FLANGE	1
10	78036041000	EXHAUST FLANGE GASKET	1
11	58030010200	SCREW IN NOZZLE M20X1,5	1
14	60030063070	OIL JET 70 M5	2
16	78136025001	VALVE GUIDE INTAKE	4
17	78030044000	CYL. HEAD SCREW M10X1,25 L=125	4
18	77336089010	WASHER 19X10,5X2,5	4
19	0025060706	HH COLLAR SCREW M6X70	TX30
20	59030296000	SCREW PLUG	3
24	61036047000	HOSE CLAMP GEMI 63MM	05
25	77236048000	HOSE CLAMP GEMI 58MM	1
26	0770100020	O-RING 10,00X2,00 SILCONE	1
27	60011252000	TEMPERAT.-SENSOR WATER LC8	02
28	58431082300	CLAMP YDNAC 10173 (18MM)	1
29	78130087000	ENGINE BREATHER TUBE	1

137893630 / C137893630

* NEW PART

X AS REQUIRED

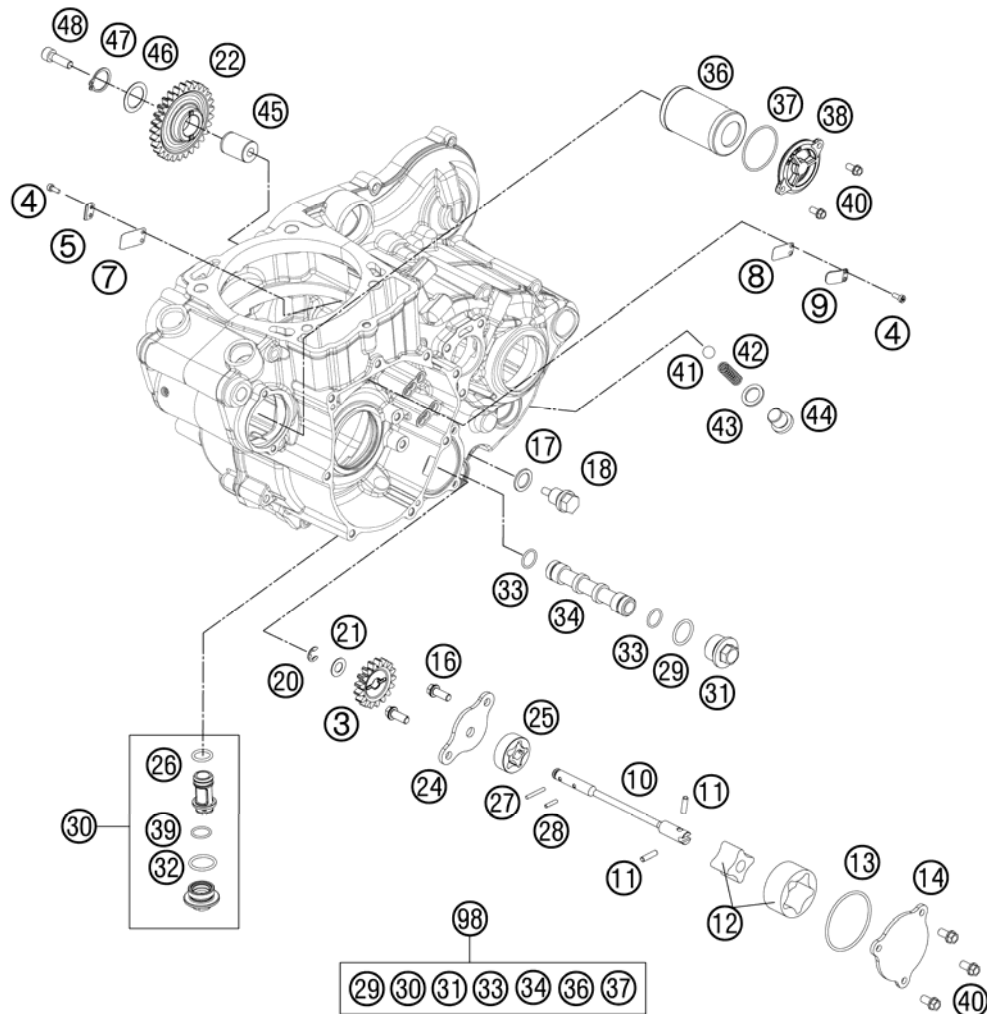

FIG	PART NUMBER	DESCRIPTION	QTY
3	78038001017	OIL PUMP GEAR 17 T	1
4	0458030080	CYLIND.SCREW M3X8 ISO 14580 SS	4
5	75030003050	STOP SHEET MEMBRANE 07	1
7	75030003051	MEMBRANE 07	1
8	81205027003	MEMBRAN CRANKCASE	1
9	81205027004	TAB WASHER MEMBRAN CSC	1
10	78138102000	OIL PUMP SHAFT SP-DP	1
11	0402041580	NEEDLE ROLLER NRB 4X15,8 G2	2
12	61238111000	ROTOR-SET CPL. 22MM	1
13	0770440020	O-RING 44,00X2,00 VITON	1
14	78038004000	OIL PUMP COVER SUCTION PUMP	1
16	0025060166	HH COLLAR SCREW M6X16 TX30	2
17	58038022000	CU-SEAL RING DIN7603-12X18X1,5	1
18	58030021000	OILDRAIN PLUG W.MAG. M 12X1,5	1
20	0799060000	TAB WASHER DIN6799-RS 6,0	1
21	58038007755	STOP DISK 8,1 X 15 X 0,5	1
22	78138001029	IDLER GEAR 1 29Z	1
24	78138003000	OIL PUMP COVER	1
25	59038011012	OILPUMP ROTOR 12MM G-95R/003	1
26	0770012021	O-RING 12X2 VITON GREEN	1
27	0402040980	NEEDLE ROL.DIN5402 NRB 4X9,8	1
28	0402251180	NEEDLE ROLLER DIN5402 2,5X11,8	1
29	0770020170	O-RING 17,17X1,78 GLO	1
30	78138015001	OIL SCREEN CPL.	1
31	59038017000	PLUG M20X1,5 WS=13	1
32	0770170200	O-RING 17,00X2,00	1
33	07701250151	O-RING 12,5X1,5 VITON V75	2
34	59038016100	OIL SCREEN	1
36	77038005044	OIL FILTER WITH GASKET 06	1
37	07700390261	O-RING 39,34X2,62	1
38	75038041200	OILFILTER CAP	1
39	0770125015	O-RING 12,5X1,5 NBR	1
40	0025050166	HH COLLAR SCREW M5X16 TX30	5
41	0401090003	BALL DIN5401-9	1
42	58038023300	PRESSURE SPRING L=25MM D=1MM	1

137893810 / C137893810

* NEW PART

X AS REQUIRED

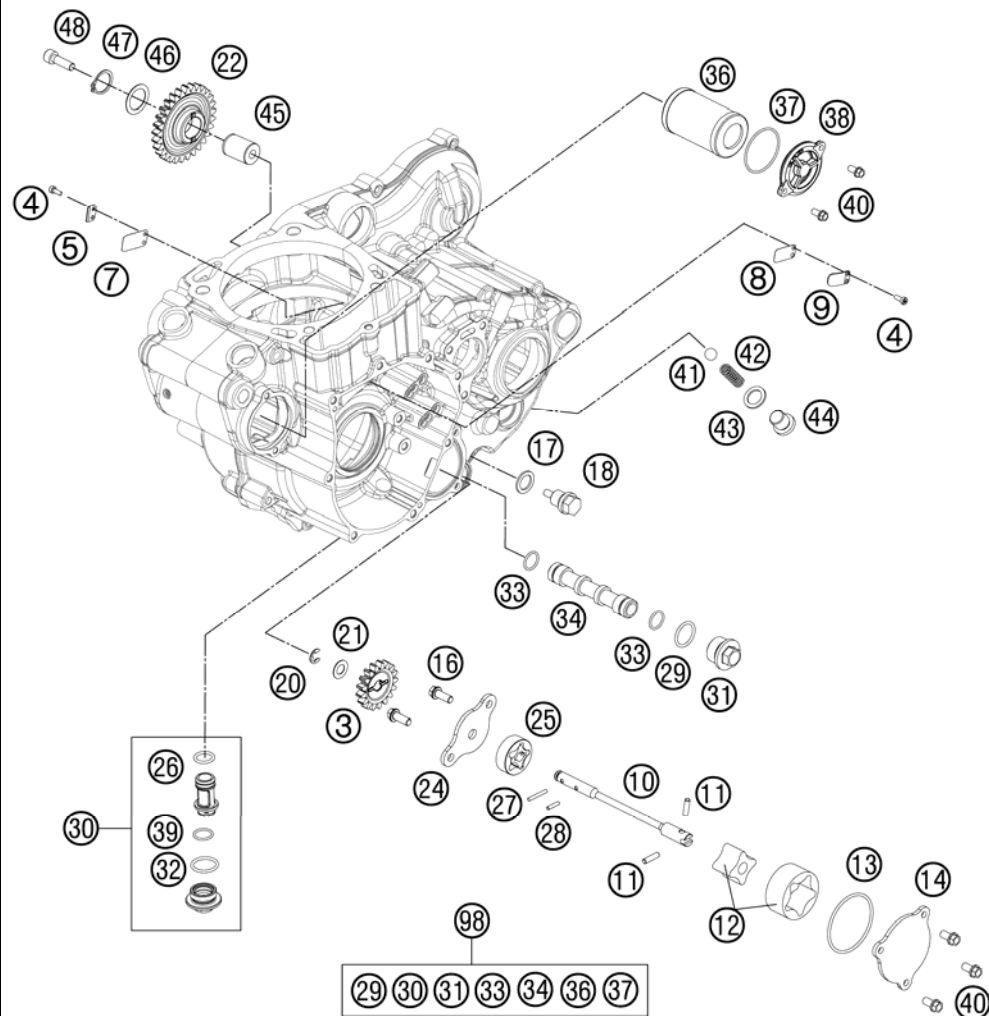

FIG	PART NUMBER	DESCRIPTION	QTY
43	58038022000	CU-SEAL RING DIN7603-12X18X1,5	1
44	78036024000	PLUG SCREW SAS M12X1,5	1
45	78040028000	BUSHING PIN	1
46	0988172405	SHIM WASHER DIN0988-17X24X0,5	1
47	0471170010	CIRCLIP DIN0471-17X1	1
48	0912060208	AH SCREW DIN0912-M 6X20 SS	1
98	78938015010	OILFILTER SERVICE KIT SX-F 13	x

137893810 / C137893810

* NEW PART

X AS REQUIRED

IGNITION SYSTEM

450 SX-F 2013

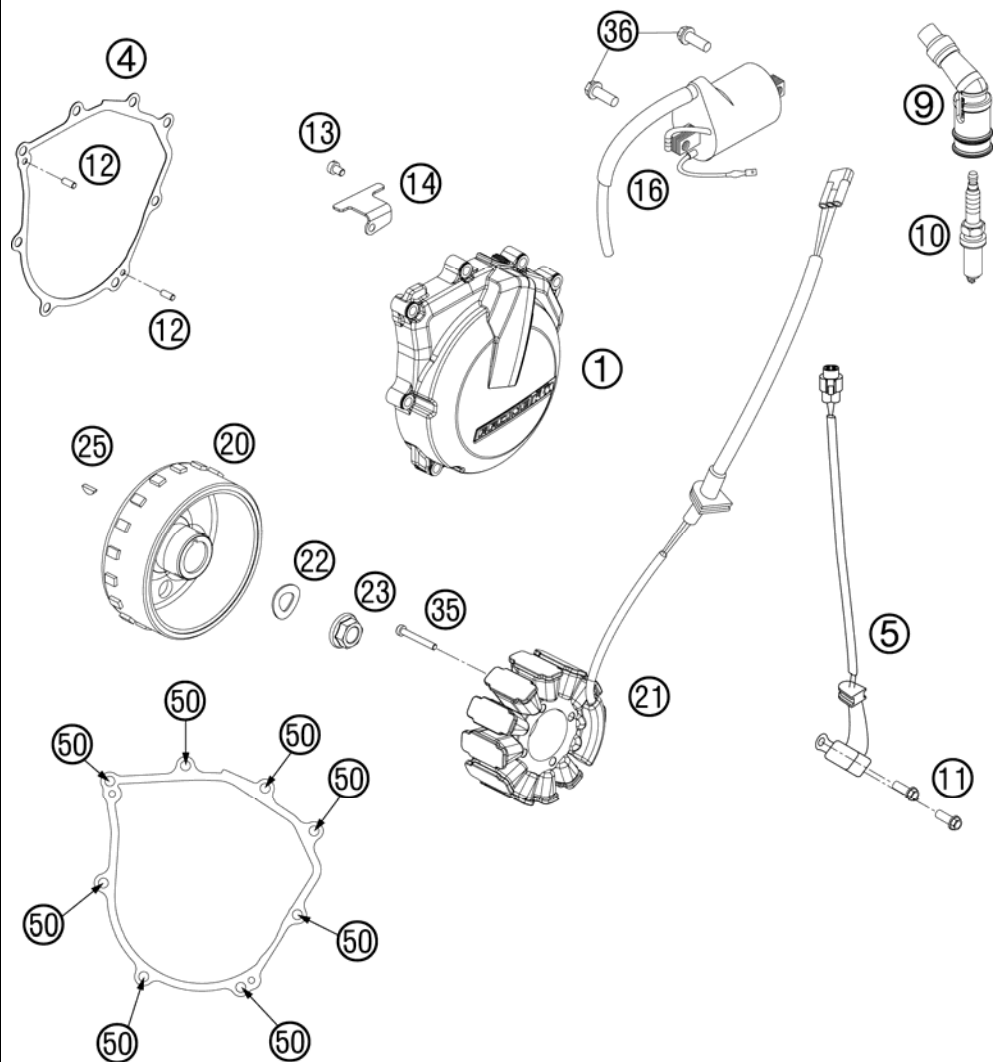

FIG	PART NUMBER	DESCRIPTION	QTY
1	7893000200015	IGNITION COVER	1
4	78130040000	GASKET - IGNITION COVER	1
5	59039034000	PULSER COIL KOKUSAN 4K3-A/B	1
9	77139090000	SPARK PLUG CONNECTOR	1
10	75039093000	SPARK PLUG M12X1,25 LKAR8AI-9	1
11	0025050166	HH COLLAR SCREW M5X16 TX30	2
12	0402040980	NEEDLE ROL.DIN5402 NRB 4X9,8	2
13	0019040106S	FLAT HEAD SCREW ISA25 M4X10	1
14	81230002010	RETAINING PLATE	1
16	58439006000	IGNITIONCOIL IG3826 KOKUSAN'96	1
20	78939005000	ROTOR	1
21	78939004000	STATOR	1
22	0137120000	SPRING WASHER DIN0137-B12	1
23	49030021000	COLLAR NUT M12X1 R/S	1
25	0888030050	WOODRUFF KEY DIN6888-3X5X13	1
35	0012040303	AH SCREW DIN6912 M4x30	4
36	0025060166	HH COLLAR SCREW M6X16 TX30	3
50	0025060256	HH COLLAR SCREW M6X25 TX30	8

137893910 / C137893910

* NEW PART

X AS REQUIRED

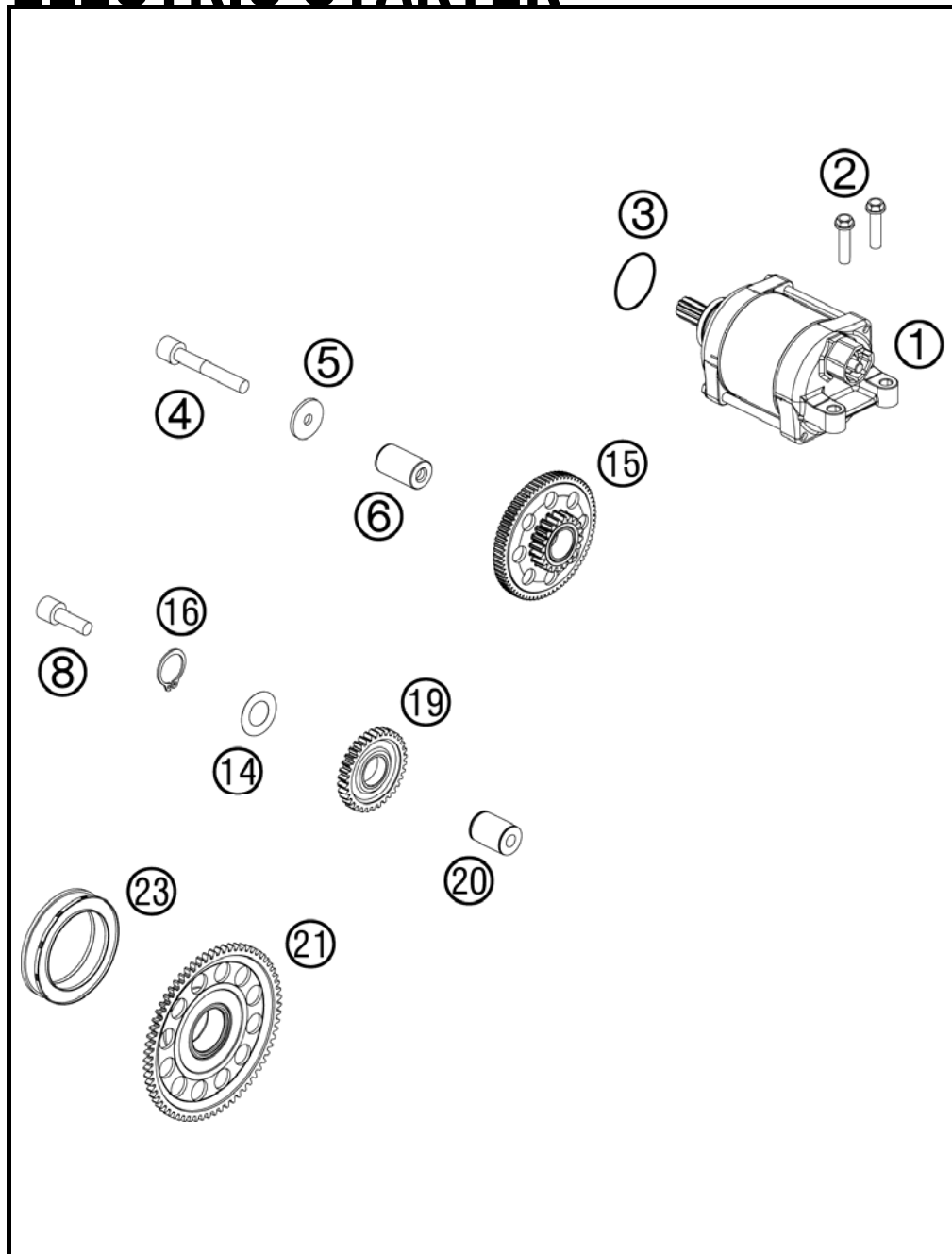

FIG	PART NUMBER	DESCRIPTION	QTY
1	78140001000	E-STARTER CPL. 0,5KW	1
2	0025060256	HH COLLAR SCREW M6X25 TX30	2
3	0770250030	O-RING 25,00X3,00 NBR 70	1
4	0912060404	AH SCREW DIN0912-M 6X40 A2	1
5	78040016004	STOP DISC 6X23X2	1
6	78040029000	BEARING BOLT	1
8	0912060208	AH SCREW DIN0912-M 6X20 SS	1
14	0988172405	SHIM WASHER DIN0988-17X24X0,5	1
15	78040016100	TORQUE LIMITER CPL.	1
16	0471170010	CIRCLIP DIN0471-17X1	1
19	78940022000	IDLER GEAR 30-T CPL.	1
20	78040028000	BUSHING PIN	1
21	78940020033	FREEWHEEL GEAR 66 C CPL.	1
23	75040026000	FREE WHEEL	1

137894010 / C137894010

* NEW PART

X AS REQUIRED

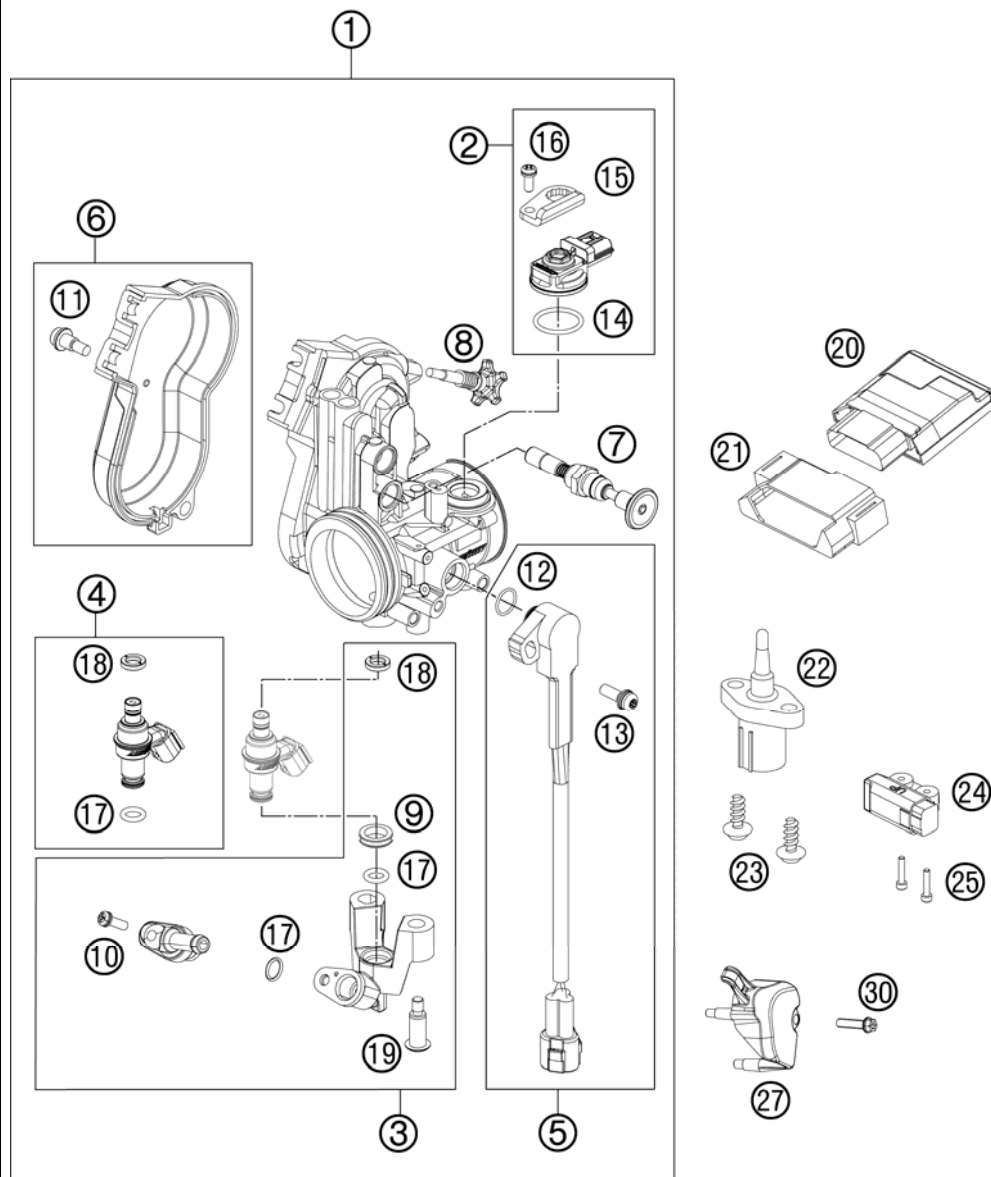

FIG	PART NUMBER	DESCRIPTION	QTY
1	77741001000	THROTTLE BODY	1
2	75041085044	MAP SENSOR CPL.	07
3	77741013044	FUEL RAIL CPL.	1
4	77741023044	INJECTOR KIT CPL.	1
5	77741077044	TPS CPL.	1
6	81241056044	THROTTLE COVER CPL.	09
7	81241060000	STARTER VALVE COMP.	1
8	77741060044	IDLING ADJUSTING SCREW CPL.	1
9	77741023030	SEAL RING	1
10	75041013010	SCREW SHOULDER	1
11	81241056020	SPECIAL SCREW AH	2
12	61041077010	O-RING THROTTLE POS. SENSOR	1
13	81241077030	SPECIAL SCREW	1
14	75041085010	O-RING	1
15	77741085020	PLATE	1
16	81241085030	SPECIAL SCREW	1
17	75041023020	O-RING	2
18	75041023010	SEAL RING	1
19	75041013060	SCREW SHOULDER	2
20	81241031100	TIMING CHARGER EFI	1
21	77241031050	RUBBER BRACKET ECU	1
22	61041080000	AMBIENT-AIR TEMPERATURE SENSOR	1
23	0025050166	HH COLLAR SCREW M5X16 TX30	2
24	61041088000	ROLLOVER SENSOR 05	1
25	0025060206	HH COLLAR SCREW M6X20 TX30	2
27	77741077050	PROTECTION CAP TPS	1
29	77741070000	STARTER VALVE COMP.	1
30	0025050256	HH. COLLAR SCREW M5X25 ISA30	1

137894110 / C137894110

* NEW PART

X AS REQUIRED







KTM-Sportmotorcycle AG
A-5230 Mattighofen
www.ktm.at

KTM Group Partner



3CM089570MEN



Art.Nr.: 3CM089570MEN 5/2012